

MOD		LOC		DIST		P		F		ZONE		LTR		REVISIONS		DATE	APPD
18	GP	00													REV PER EC 0513-0177-03	5-03	CR

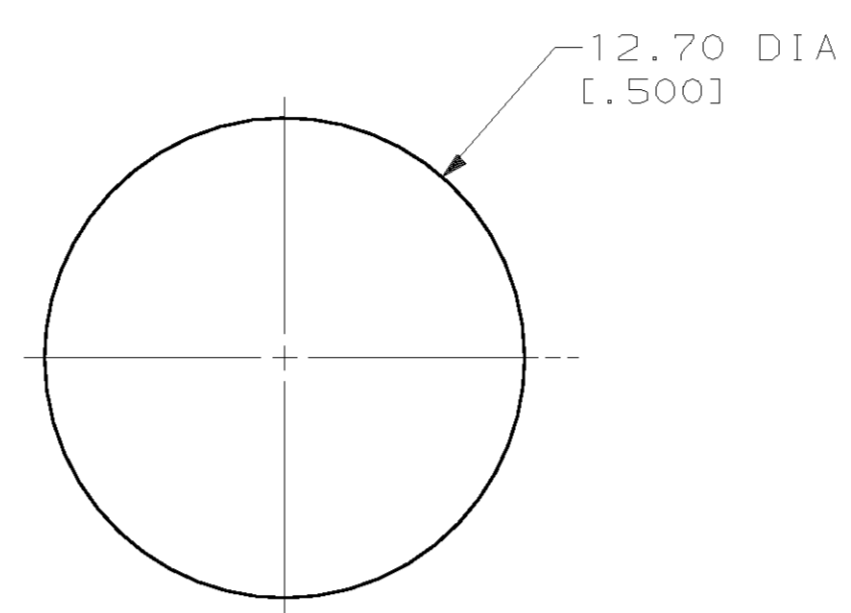

RECOMMENDED PANEL CUT-OUT

- △ SHELL: BRASS; CONTACTS: PHOSPHOR BRONZE; HOUSING: POLYESTER, UL 94V-0 RATED, BLACK.
- △ 0.76 μm [.000030] MIN GOLD ON MATING END FOR A LENGTH OF 1.37 [.054] MIN ON INSIDE, 2.54 μm [.000100] MIN TIN-LEAD FOR A LENGTH OF 3.30 [.130] MIN FROM OPPOSITE END, ALL OVER 1.27 μm [.000050] MIN NICKEL.
- △ 0.38 μm [.000015] MIN GOLD ON MATING END FOR A LENGTH OF 1.37 [.054] MIN ON INSIDE, 2.54 μm [.000100] MIN TIN-LEAD FOR A LENGTH OF 3.30 [.130] MIN FROM OPPOSITE END, ALL OVER 1.27 μm [.000050] MIN NICKEL.
- △ 2.54 μm [.000100] MIN TIN-LEAD OVER 1.27 μm [.000050] MIN NICKEL.
- △ GOLD PLATING PER MIL-G-45204, TIN PLATING PER MIL-T-10727, NICKEL PLATING PER QQ-N-290.
- 6. RECEPTACLE ASSEMBLY MATES WITH 6 PIN, 8.99±0.10 [.354±.004] DIAMETER PLUG.
- △ 2.54 μm [.000100] MIN TIN OVER 1.27 μm [.000050] MIN NICKEL.

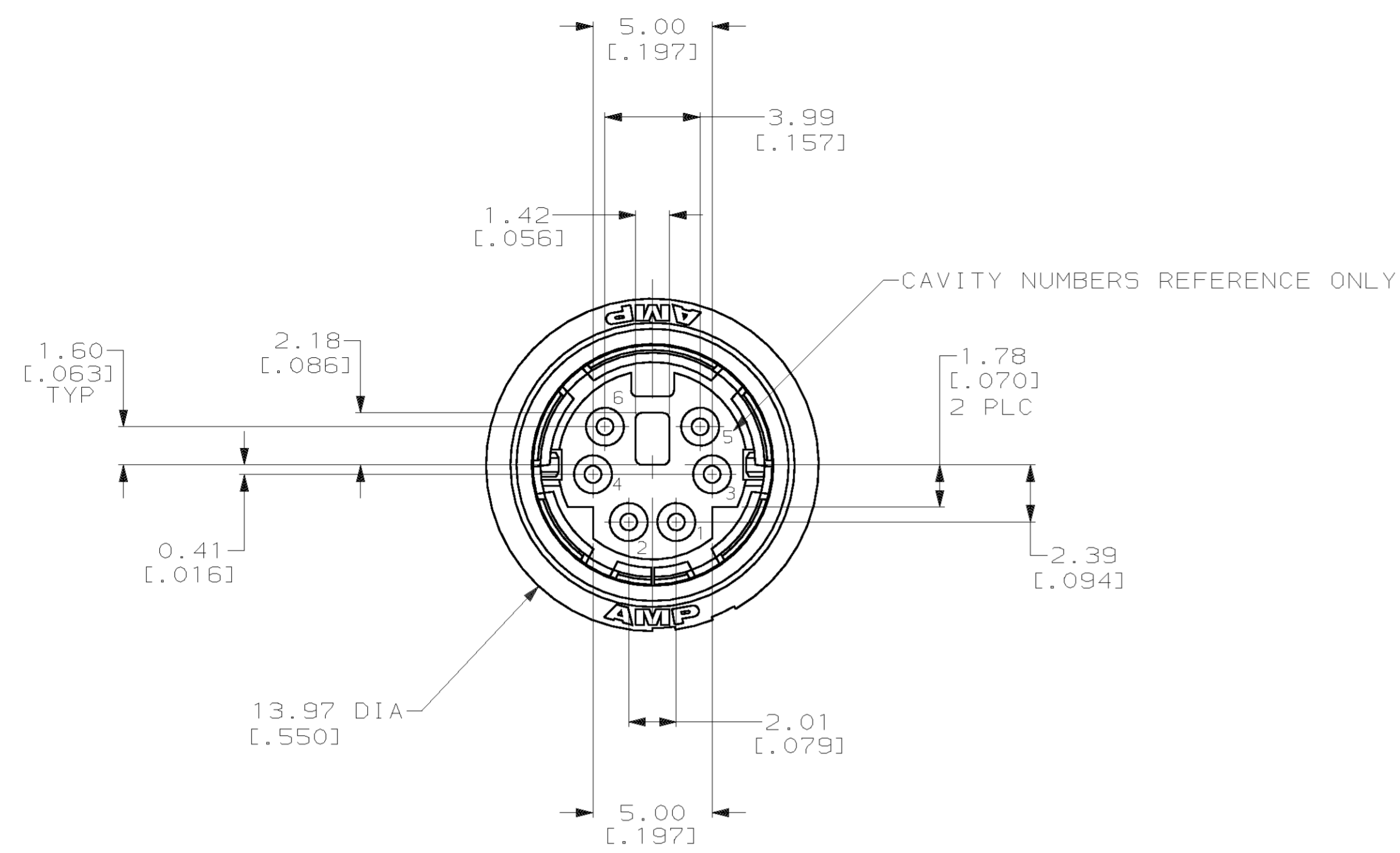
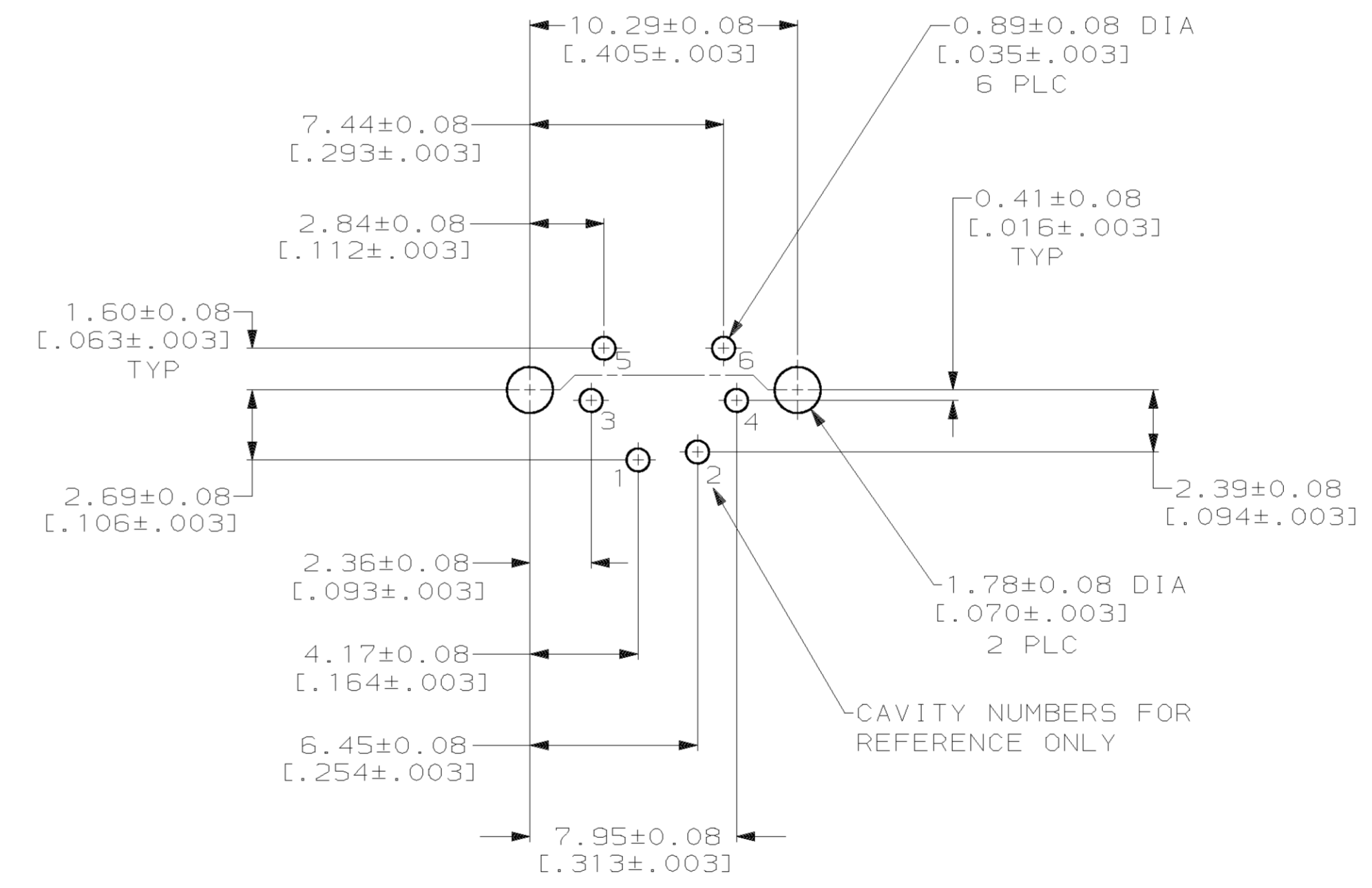
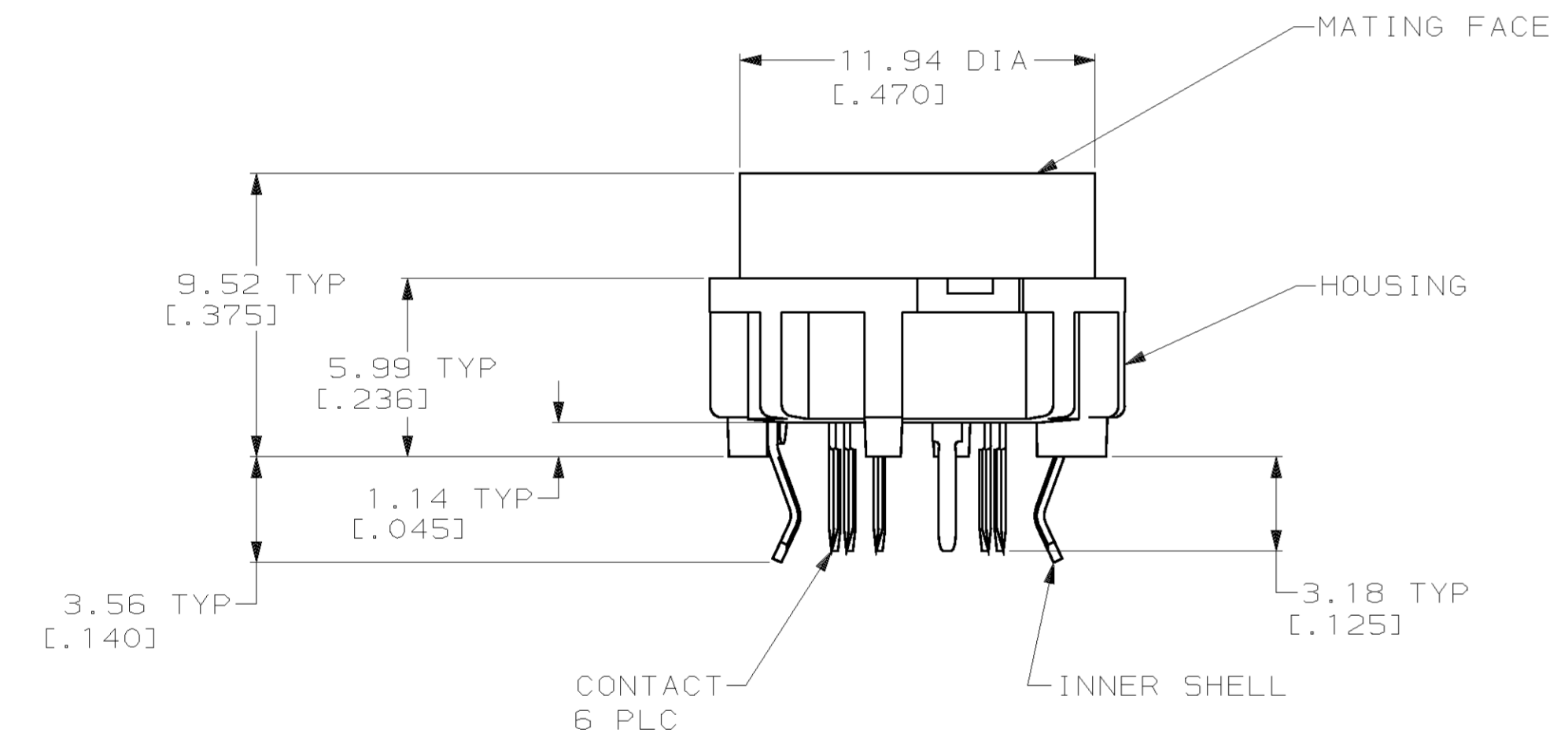

RECOMMENDED PC BOARD LAYOUT
 BOTTOM VIEW

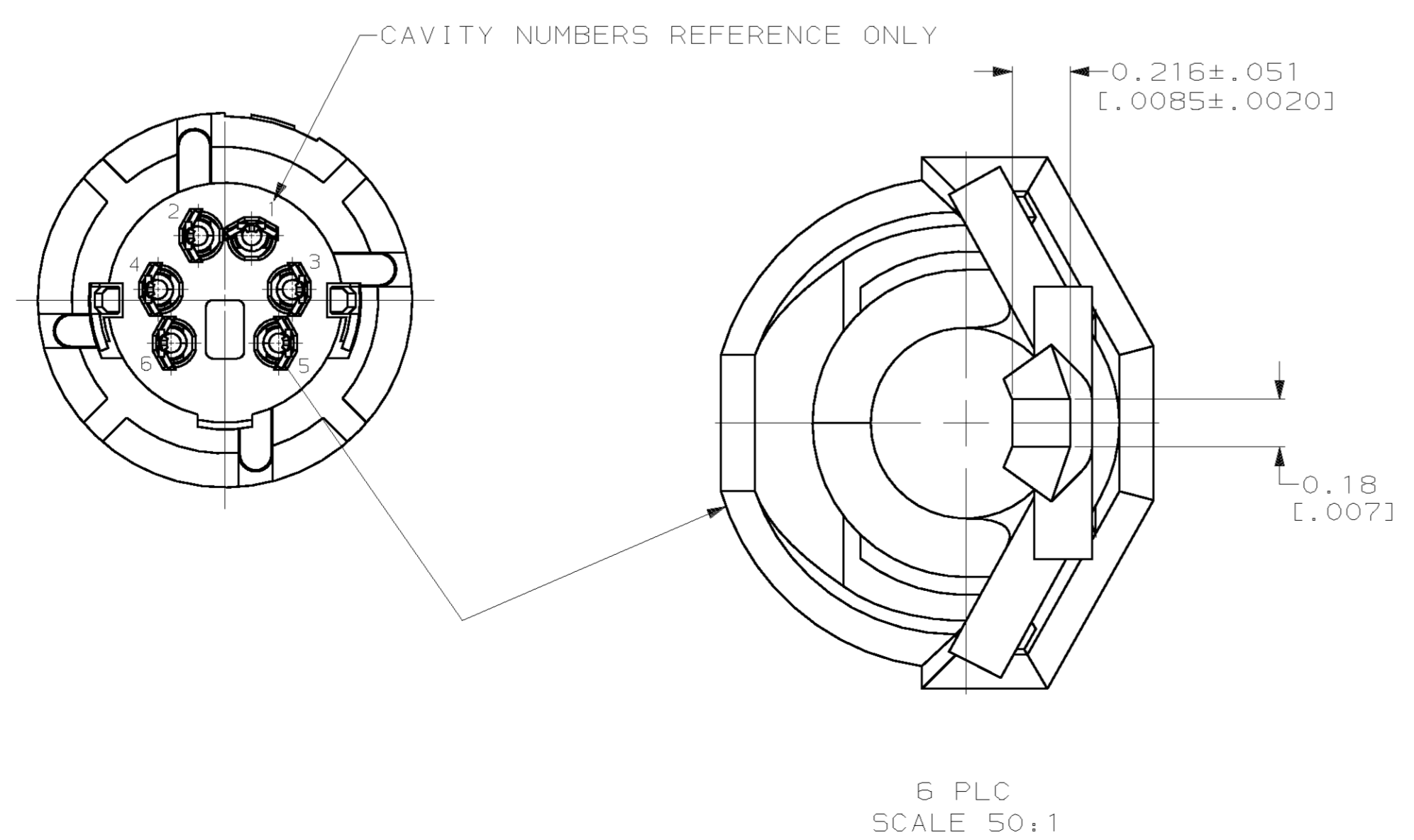

△ 1	△ 2	△ 3	750327-3
△ 4	△ 5	△ 6	750327-2
△ 4	△ 5	△ 6	750327-1
INNER SHELL FINISH	CONTACT FINISH	PART NO	

DO NOT SCALE PRINT. UNLESS SPECIFIED DIMENSIONS IN mm [INCHES]	DR 8-6-90 R. SHIREY	AMP Incorporated Harrisburg, PA 17105-3608	
TOLERANCES ON:	CHK -	NAME	
2 PLC DEC ± 0.13 [.005]	APPD -	RECEPTACLE ASSEMBLY, 6 POSN, LOW FLANGE, UNSHIELDED, VERTICAL, MINIATURE CIRCULAR DIN	
3 PLC DEC ± -	APPD -	SIZE D	
ANGLES ± -	APPD -	CAGE CODE 00779	
MATERIAL	PRODUCT SPEC -	DRAWING NO 750327	
FINISH	APPLICATION SPEC -	SCALE 5:1	
SEE TABLE	WEIGHT -	SHEET 1 OF 1	

