

THIS DRAWING IS UNPUBLISHED. RELEASED FOR PUBLICATION
 © COPYRIGHT BY TYCO ELECTRONICS CORPORATION. ALL RIGHTS RESERVED.

LOC	DIST	REVISIONS					
FT	0	P	LTR	DESCRIPTION	DATE	DWN	APVD
		T		REVISED PER ECO-06-24225	10/18/06	SS	SH

NOTES:

- ① POSTS WILL BE ORIENTED WITH SEAM TOWARD INK STAMPED EDGE, OR ROTATED 180°.
- ② .000030 MIN GOLD FOR A LENGTH OF .200 MIN FROM MATING END, .000100 MIN TIN-LEAD FOR A LENGTH OF DIMENSION 'A' FROM OPPOSITE END, ALL OVER .000050 MIN NICKEL.
- ③ .000030 MIN GOLD FOR A LENGTH OF .200 MIN FROM MATING END, .000100 MIN TIN FOR A LENGTH OF DIMENSION 'A' FROM OPPOSITE END, ALL OVER .000050 MIN NICKEL.

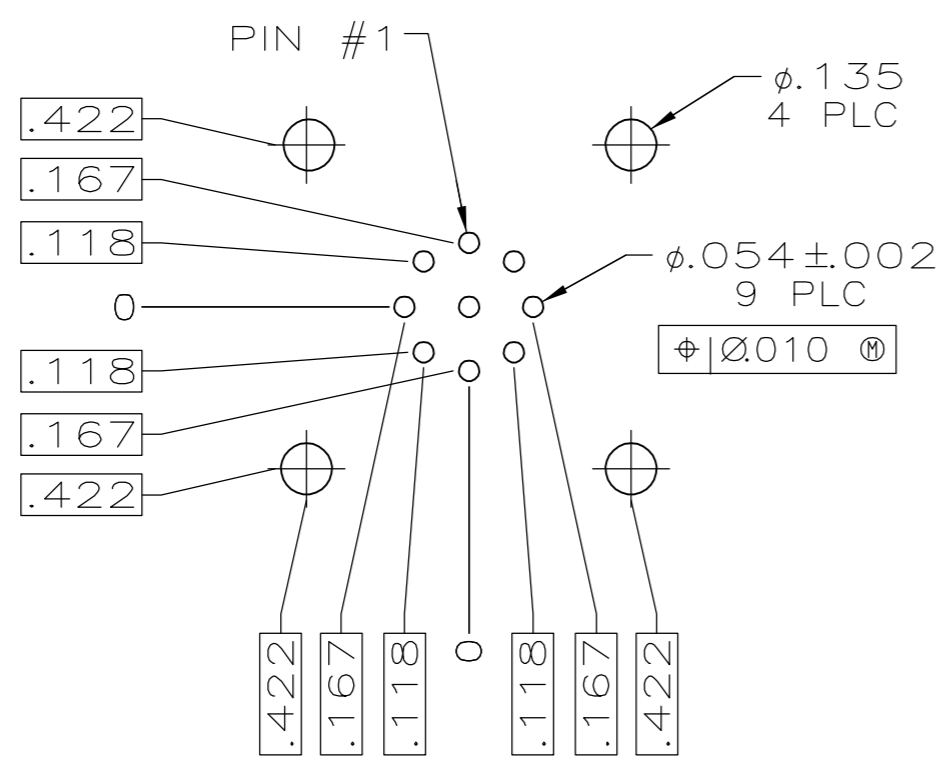
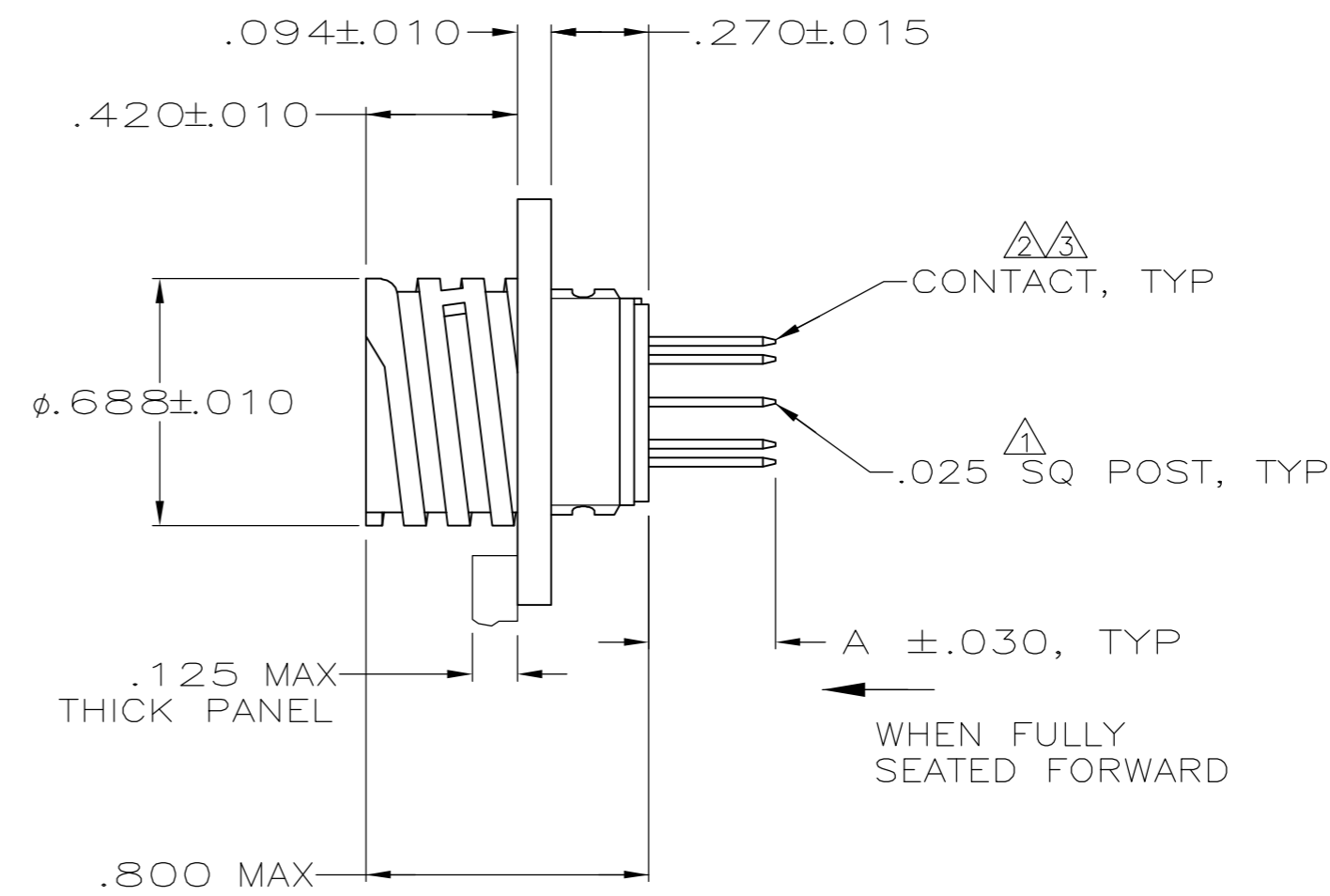
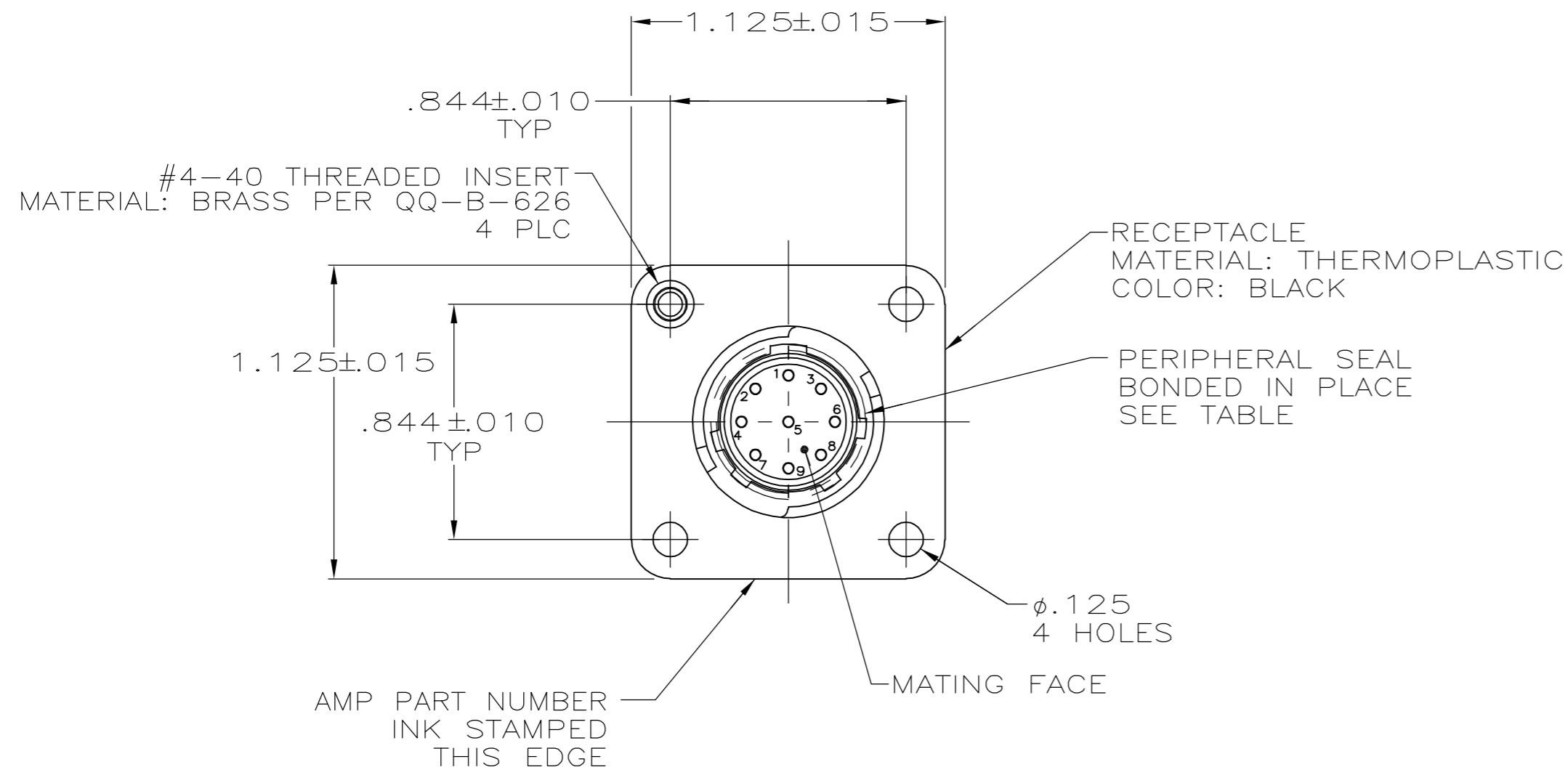

RECOMMENDED PC BOARD LAYOUT

	③	.125	NO	NO	1-206852-2
	③	.352	NO	NO	1-206852-1
PRELIMINARY	②	.125	YES	YES	1-206852-0
PRELIMINARY	②	.796	YES	YES	206852-9
	②	-	NO	YES	206852-8
OBSOLETE	②	-	NO	NO	206852-7
OBSOLETE	②	-	NO	NO	206852-6
OBSOLETE	②	-	NO	NO	206852-5
OBSOLETE	②	.352	NO	NO	206852-4
OBSOLETE	②	.574	NO	NO	206852-3
	②	.125	NO	NO	206852-2
	②	.352	NO	NO	206852-1
CONTACT FINISH		DIM A	PERIPHERAL SEAL	THREADED INSERTS	PART NUMBER

THIS DRAWING IS A CONTROLLED DOCUMENT.

DIMENSIONS: INCHES	TOLERANCES UNLESS OTHERWISE SPECIFIED:	DWN J GALLUCCI BG 5-22-91	Tyco Electronics Corporation Harrisburg, PA 17105-3608
		CHK W.G.LENKER 4-13-92	
		APVD -	NAME
		PRODUCT SPEC	RECEPTACLE ASSEMBLY, POSTED, STD SEX, SERIES 2, 11-9, CPC
		APPLICATION SPEC	
MATERIAL SEE CALLOUT	FINISH -	WEIGHT -	SIZE A2 CAGE CODE 00779 DRAWING NO C=206852 RESTRICTED TO -
		CUSTOMER DRAWING	SCALE 2:1 SHEET 1 of 1 REV T

206852