

LOC	DIST	REVISIONS					
AD	00	P	LTR	DESCRIPTION	DATE	DWN	APVD
		B3		REVISED PER ECO-08-022187	06SEP2008	HMR	DR

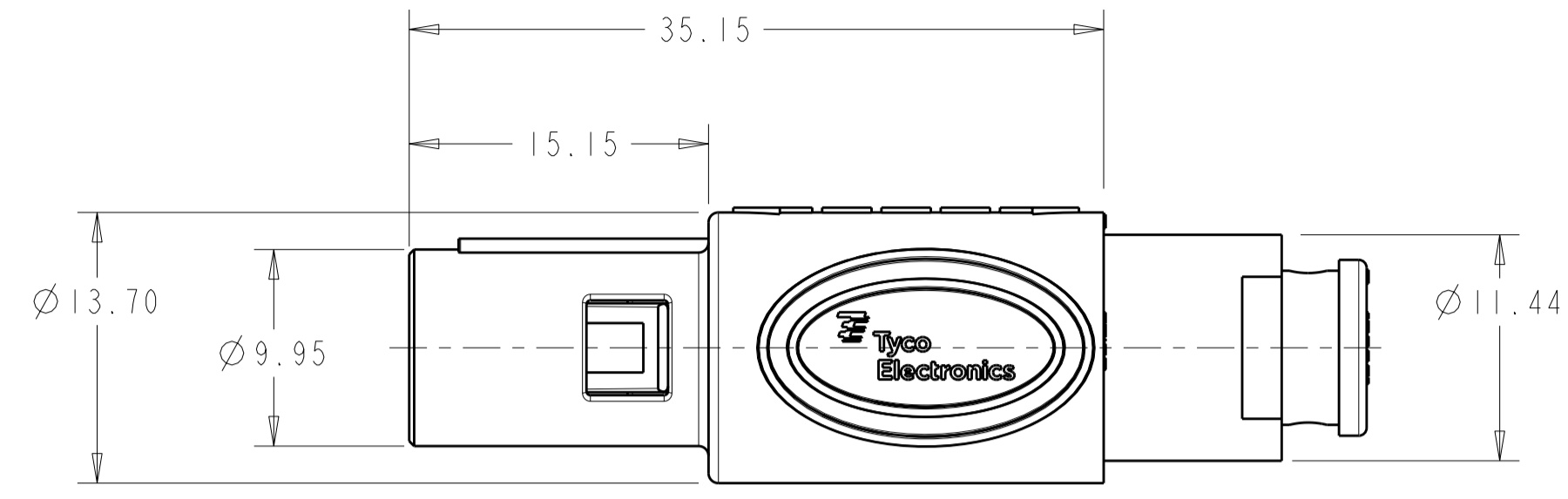

SCALE 3:1

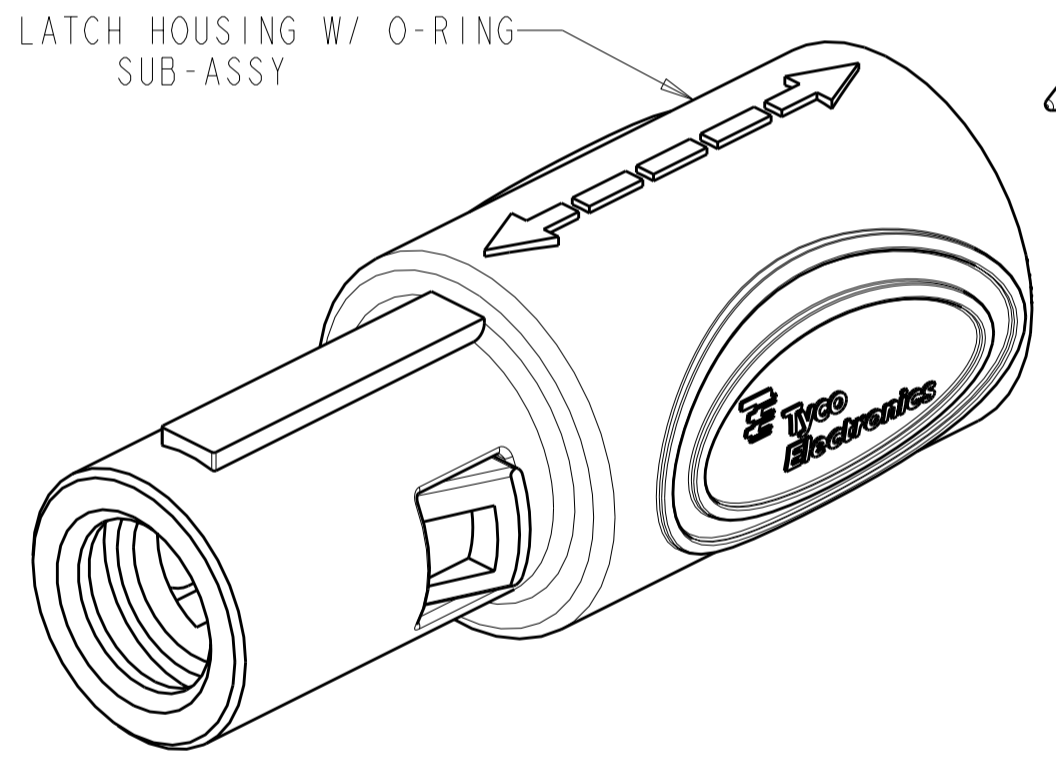
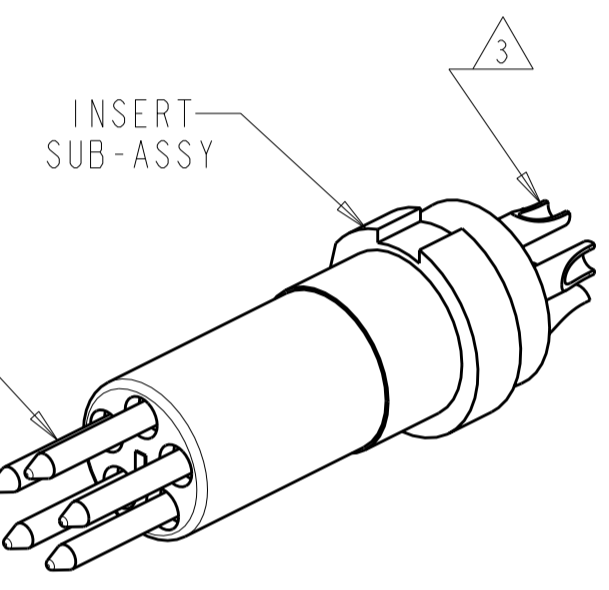
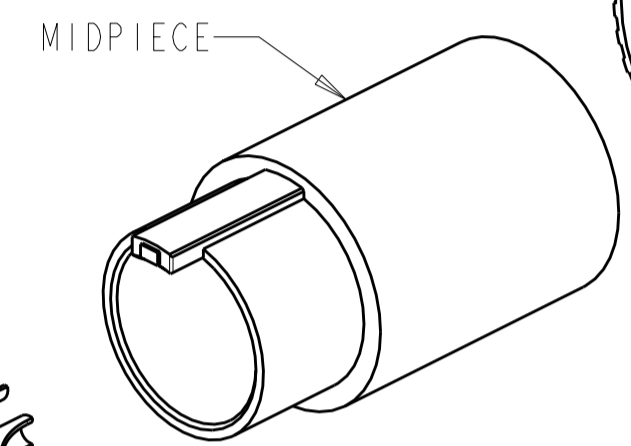
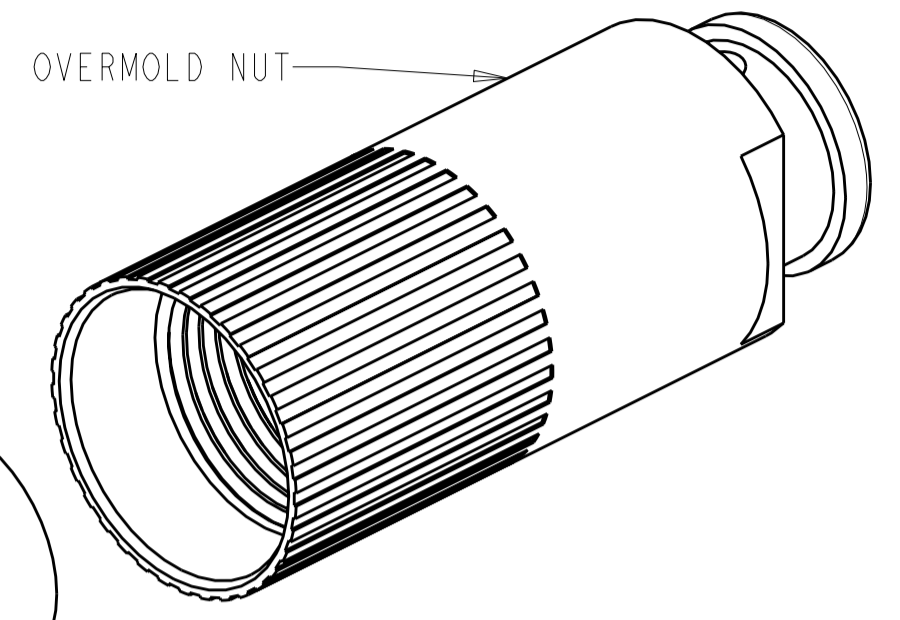

MALE CONTACT

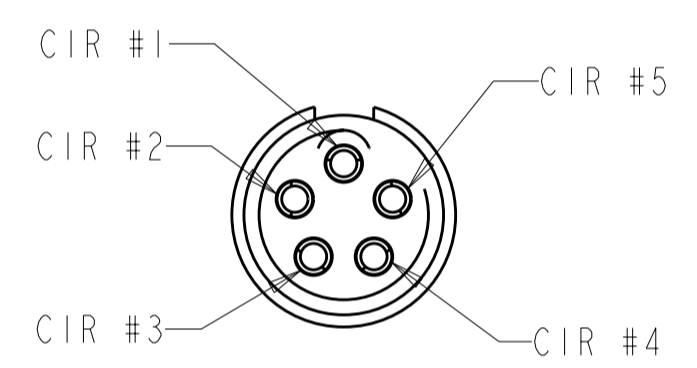

INSERT SUB-ASSY
CIRCUIT DESIGNATION VIEW

- 1 MATERIAL:
CONTACT: BRASS
LATCH HOUSING, INSERT, MIDPIECE, NUT:
UL 94V-0 RATED THERMOPLASTIC
O-RING: ELASTOMER
COLOR:
MIDPIECE AND INSERT: GRAY
LATCH HOUSING AND OVERMOLD NUT: SEE TABLE
O-RING: BLACK
- 2 FINISH:
CONTACT, 0.75µm MIN. GOLD OVER NICKEL
- 3 SOLDER TERMINATION CONTACT, 22 AWG WIRE MAX.
- 4. PRODUCT IS SUPPLIED UNASSEMBLED
- 5 PRELIMINARY PART NUMBER.

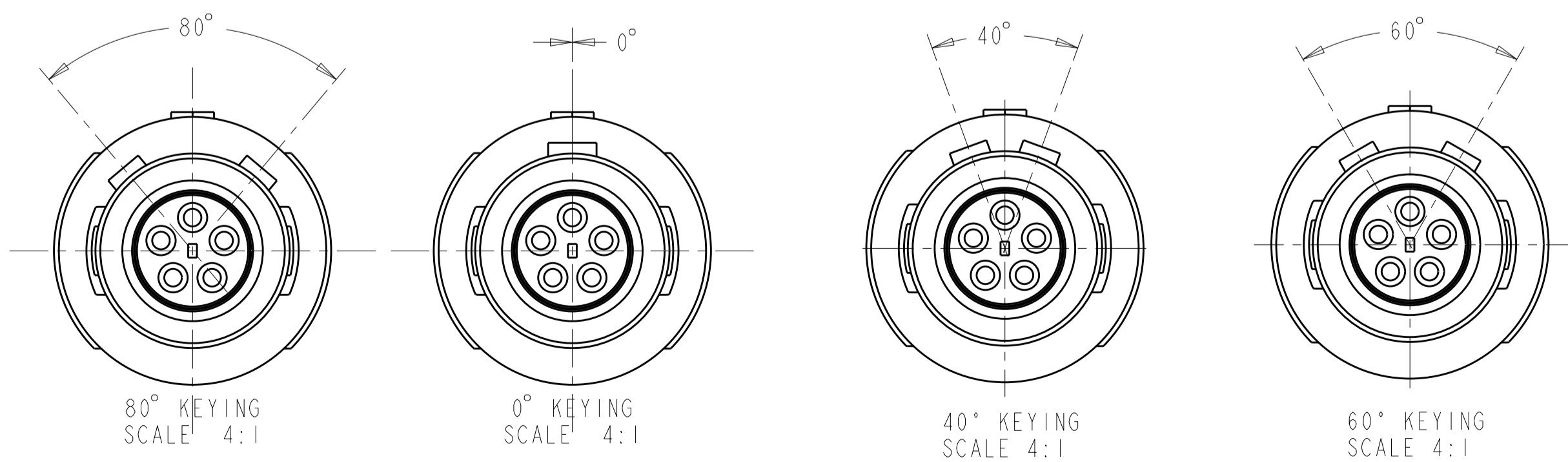

5	GRAY	60°	1877849-8
5	BLACK	60°	1877849-7
5	GRAY	40°	1877849-6
5	BLACK	40°	1877849-5
	GRAY	80°	1877849-4
	BLACK	80°	1877849-2
	BLACK	0°	1877849-1
	LATCH HOUSING AND NUT COLOR	KEYING	PART NO.

THIS DRAWING IS A CONTROLLED DOCUMENT FOR TYCO ELECTRONICS CORPORATION. IT IS SUBJECT TO CHANGE AND THE CONTROLLING ENGINEERING ORGANIZATION SHOULD BE CONTACTED FOR THE LATEST REVISION.		DWN K. MILLER 09MAR2006	Tyco Electronics Harrisburg, PA 17105-3608	
DIMENSIONS: mm		CHK L. BREKOSKY 09MAR2006	NAME	
TOLERANCES UNLESS OTHERWISE SPECIFIED: 0 PLC ± 1 PLC ±0.13 2 PLC ±0.08 3 PLC ± 4 PLC ± ANGLES ±1° FINISH		APVD -	PRODUCT SPEC 108-2249	
MATERIAL		APVD -	APPLICATION SPEC 114-13184	
1		WEIGHT -		SIZE A2
2		CUSTOMER DRAWING		CAGE CODE 00779
		SCALE 5:1		DRAWING NO. 1877849
		SHEET 1		RESTRICTED TO -
		OF 1		REV B3