

THIS DRAWING IS UNPUBLISHED. RELEASED FOR PUBLICATION 20  
 © COPYRIGHT 20 BY TYCO ELECTRONICS CORPORATION. ALL RIGHTS RESERVED.

LOC		DIST		REVISIONS			
P	LTR	DESCRIPTION	DATE	DWN	APVD		
	B3	REVISED PER ECO-08-022187	06SEP2008	HMR	DR		

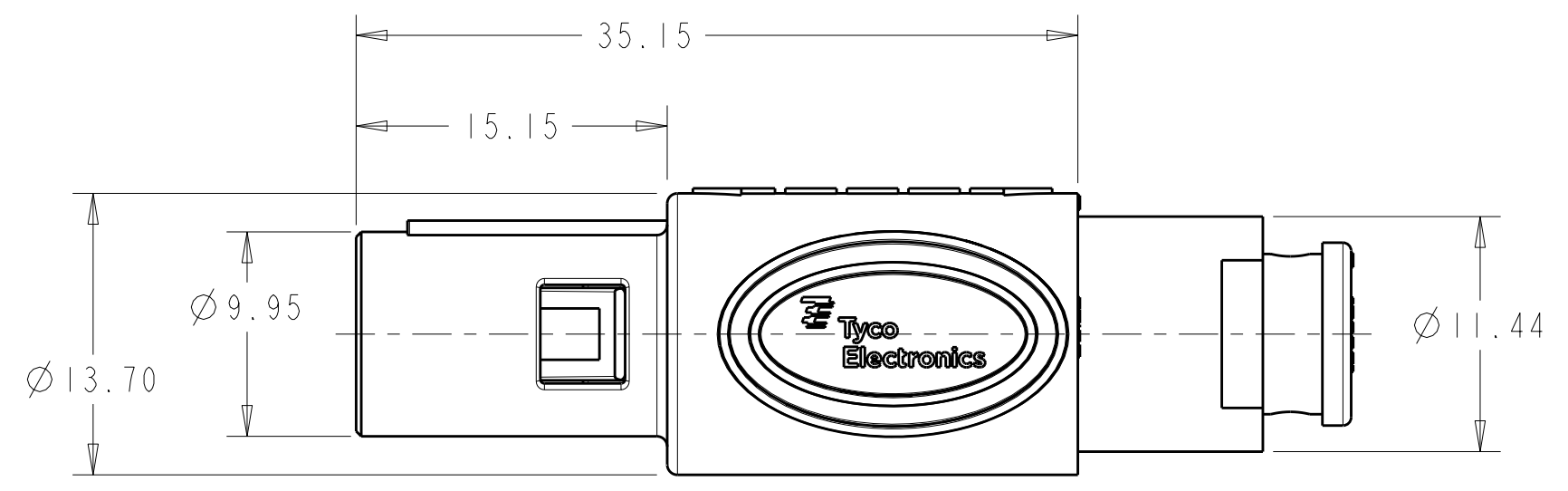

SCALE 3:1

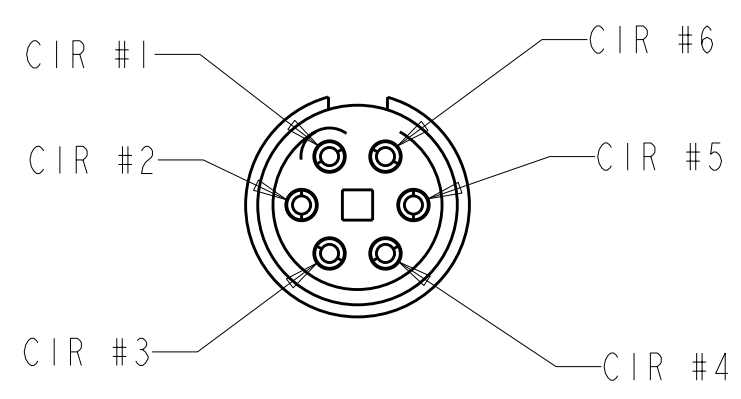

INSERT SUB-ASSY  
CIRCUIT DESIGNATION VIEW

KEYED LATCH HOUSING W/ O-RING  
SUB-ASSY

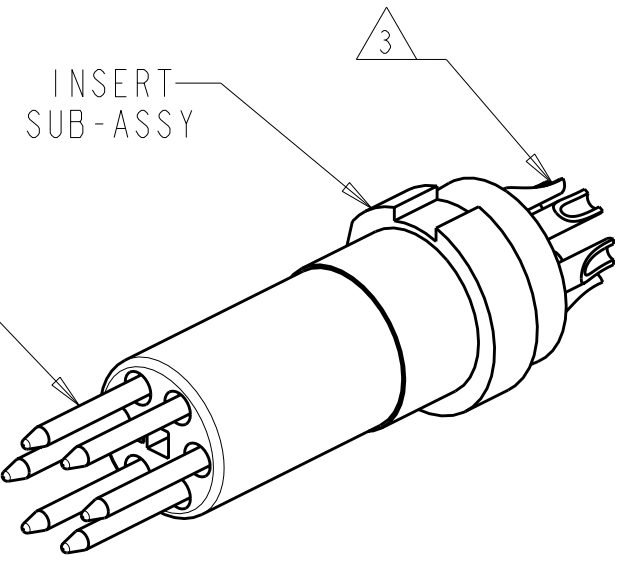
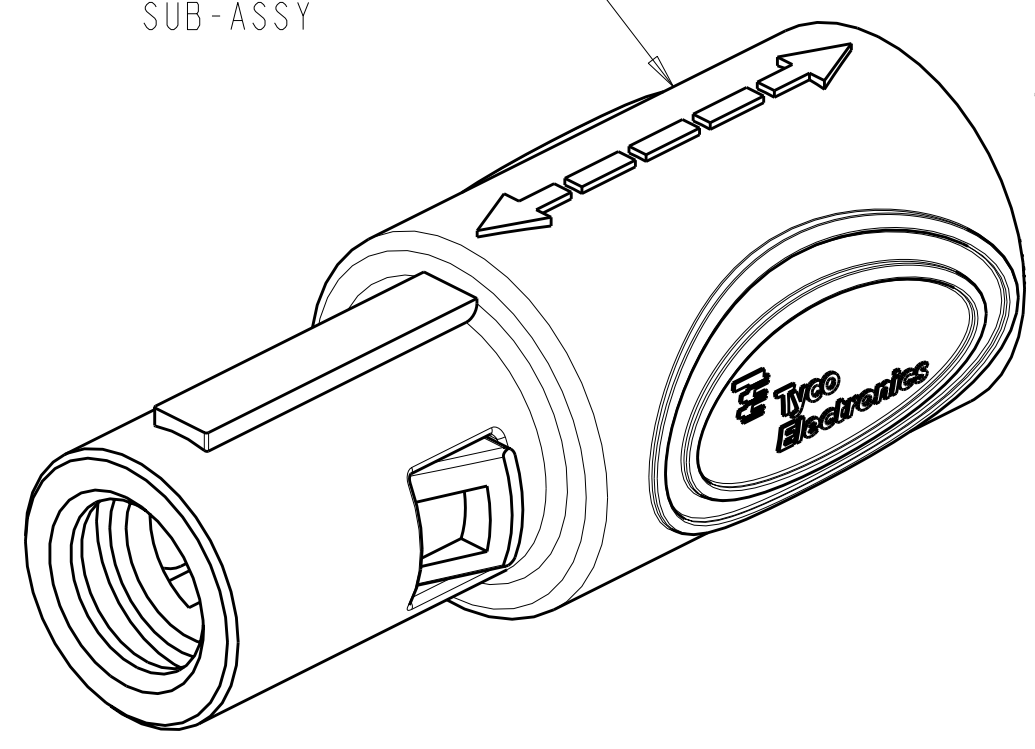

MALE CONTACT

INSERT  
SUB-ASSY

MIDPIECE

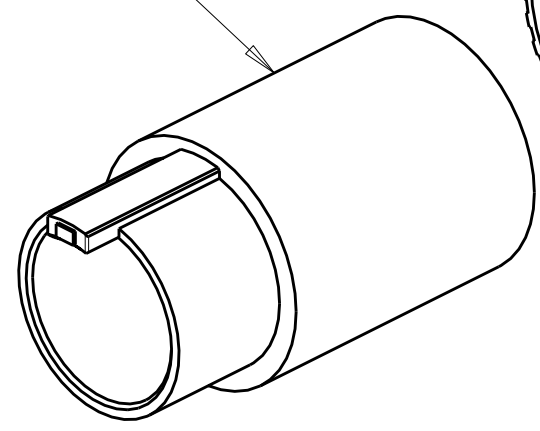

OVERMOLD NUT

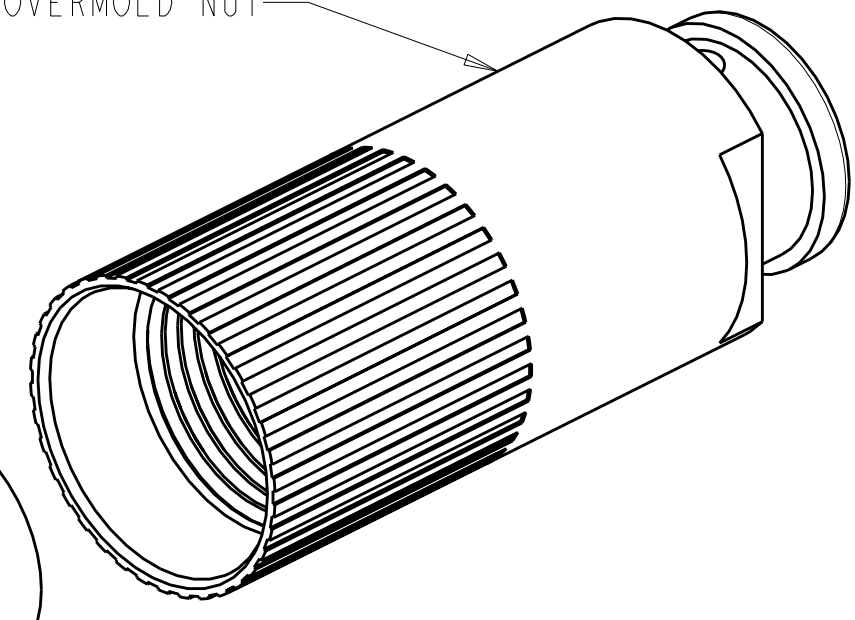

- 1 MATERIAL:  
CONTACT: BRASS  
LATCH HOUSING, INSERT, MIDPIECE, NUT:  
UL 94V-0 RATED THERMOPLASTIC  
O-RING: ELASTOMER  
COLOR:  
MIDPIECE AND INSERT: GRAY  
LATCH HOUSING AND OVERMOLD NUT: SEE TABLE  
O-RING: BLACK
- 2 FINISH:  
CONTACT, 0.75µm MIN. GOLD OVER NICKEL
- 3 SOLDER TERMINATION CONTACT, 26 AWG WIRE MAX.
- 4. PRODUCT IS SUPPLIED UNASSEMBLED.
- 5 PRELIMINARY PART NUMBER.

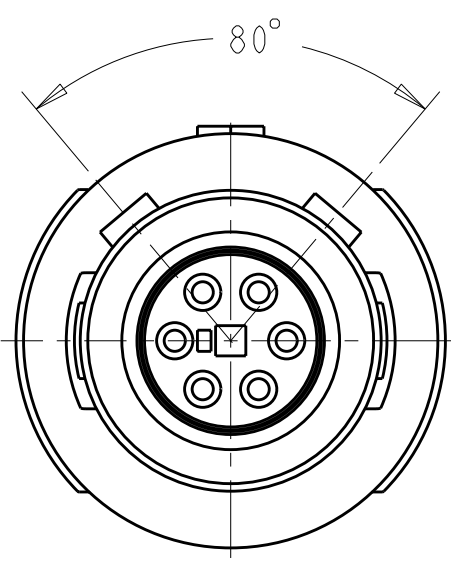

80° KEYING  
SCALE 4:1

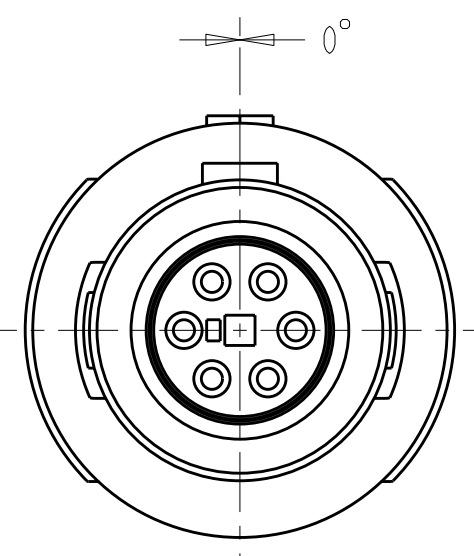

0° KEYING  
SCALE 4:1

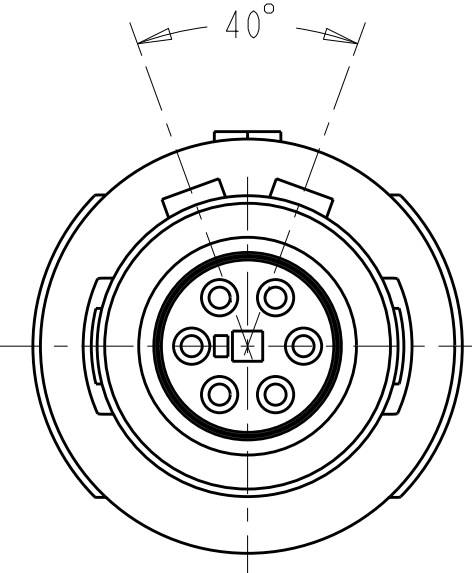

40° KEYING  
SCALE 4:1

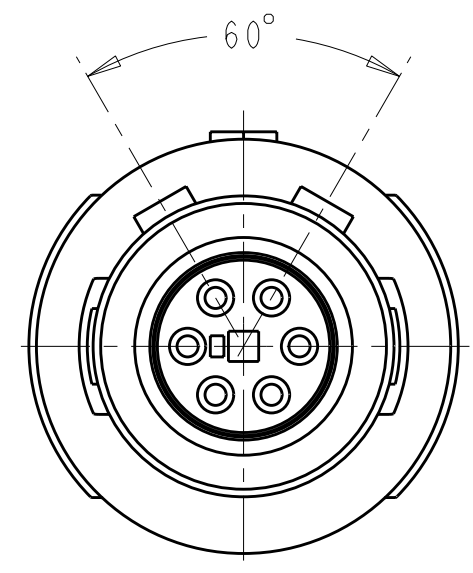

60° KEYING  
SCALE 4:1

5	GRAY	60°	1877850-8
5	BLACK	60°	1877850-7
5	GRAY	40°	1877850-6
5	BLACK	40°	1877850-5
	GRAY	80°	1877850-4
	GRAY	0°	1877850-3
	BLACK	80°	1877850-2
	BLACK	0°	1877850-1
	LATCH HOUSING AND NUT COLOR	KEYING	PART NO.

THIS DRAWING IS A CONTROLLED DOCUMENT FOR TYCO ELECTRONICS CORPORATION. IT IS SUBJECT TO CHANGE AND THE CONTROLLING ENGINEERING ORGANIZATION SHOULD BE CONTACTED FOR THE LATEST REVISION.		DWN K. MILLER 09MAR2006	Tyco Electronics Harrisburg, PA 17105-3608	
DIMENSIONS: mm		CHK L. BREKOSKY 09MAR2006	NAME 6 POSITION OVERMOLD CABLE NUT STRAIGHT PLUG ASSEMBLY	
TOLERANCES UNLESS OTHERWISE SPECIFIED: 0 PLC ± 1 PLC ±0.13 2 PLC ±0.08 3 PLC ± 4 PLC ± ANGLES ±1° FINISH		APVD -	PRODUCT SPEC 108-2249	RESTRICTED TO -
MATERIAL		APPLICATION SPEC 114-13184	SIZE A2	CAGE CODE 00779
1		WEIGHT -	DRAWING NO. C-1877850	SCALE 5:1
2		CUSTOMER DRAWING	SHEET 1	OF 1
			REV B3	