

COUNT	DESCRIPTION OF REVISIONS	BY	CHKD	DATE	COUNT	DESCRIPTION OF REVISIONS	BY	CHKD	DATE
△					△				
△					△				

APPLICABLE STANDARD				
RATING	OPERATING TEMPERATURE RANGE	-10 °C TO +60 °C	STORAGE TEMPERATURE RANGE	-10 °C TO +60 °C
	VOLTAGE	AC 100 V, DC 140 V		
	CURRENT	1 A	APPLICABLE CABLE	

SPECIFICATIONS

ITEM	TEST METHOD	REQUIREMENTS	GT	AT
------	-------------	--------------	----	----

CONSTRUCTION				
GENERAL EXAMINATION	VISUALLY AND BY MEASURING INSTRUMENT.	ACCORDING TO DRAWING.	×	×
MARKING	CONFIRMED VISUALLY.		×	×

ELECTRIC CHARACTERISTICS				
CONTACT RESISTANCE	CONTACT SHALL BE MEASURED AT DC 1 A	10 mΩ MAX.	×	×
INSULATION RESISTANCE	100 V DC.	200 MΩ MIN.	×	×
VOLTAGE PROOF	300 V AC FOR 1 min.	NO FLASHOVER OR BREAKDOWN.	×	×

MECHANICAL CHARACTERISTICS				
CONTACT INSERTION AND WITHDRAWAL FORCES	$\phi 0.610^{+0}_{-0.003}$ BY STEEL GAUGE.	INSERTION AND WITHDRAWAL FORCES : 0.2 N.	×	×
CONNECTOR INSERTION AND WITHDRAWAL FORCES	MEASURED BY APPLICABLE CONNECTOR.	INSERTION AND WITHDRAWAL FORCES LOCKING DEVICE WITH UNLOCK : 50 N MAX.	×	—
MECHANICAL OPERATION	1000 TIMES INSERTIONS AND EXTRACTIONS.	CONTACT RESISTANCE: 15 mΩ MAX.	×	—
VIBRATION	FREQUENCY 10 TO 55 Hz, SINGLE AMPLITUDE 0.75 mm, — m/s ² AT 2 h, FOR 3 DIRECTIONS.	① NO ELECTRICAL DISCONTINUITY OF 10 μs. ② NO DAMAGE, CRACK AND LOOSENESS, OF PARTS.	×	—
SHOCK	490 m/s ² DIRECTIONS OF PULSE 11 ms AT 3 TIMES FOR 3 DIRECTIONS.	① NO ELECTRICAL DISCONTINUITY OF 10 μs. ② NO DAMAGE, CRACK AND LOOSENESS, OF PARTS.	×	—

ENVIRONMENTAL CHARACTERISTICS				
DAMP HEAT (STEADY STATE)	EXPOSED AT 40 °C, 90 TO 95 %, 96 h.	① INSULATION RESISTANCE: 2 MΩ MIN (AT HIGH HUMIDITY). ② INSULATION RESISTANCE: 20 MΩ MIN (AT DRY). ③ NO DAMAGE, CRACK AND LOOSENESS OF PARTS.	×	—
RAPID CHANGE OF TEMPERATURE	TEMPERATURE -55 → R/T ⁽¹⁾ → +85 → R/T °C TIME 30 → 10 TO 15 → 30 → 10 TO 15 min UNDER 5 CYCLES.	① INSULATION RESISTANCE: 200 MΩ MIN. ② NO DAMAGE, CRACK AND LOOSENESS OF PARTS.	×	—
CORROSION SALT MIST	EXPOSED IN 5 % SALT WATER SPRAY FOR 48 h.	NO HEAVY CORROSION.	×	—
DRY HEAT	EXPOSED AT + 85 °C, 96 h.	NO DAMAGE, CRACK AND LOOSENESS OF PARTS.	×	—
COLD	EXPOSED AT - 55 °C, 96 h.	NO DAMAGE, CRACK AND LOOSENESS OF PARTS.	×	—
RESISTANCE TO SOLDERING HEAT	SOLDER TEMPERATURE, + 350 ± 10 °C, FOR SOLDERING DURATION, 3 ~ 4 s.	NO DEFORMATION OF CASE OF EXCESSIVE LOOSENESS OF THE TERMINALS.	×	—
SOLDERABILITY	SOLDERED AT SOLDER TEMPERATURE, + 350 ± 10 °C FOR SOLDERING DURATION, 2 ~ 3 s.	WETTING ON SOLDER SURFACE, NO SOLDER CLUSTER.	×	—

REMARKS		DRAWN	DESIGNED	CHECKED	APPROVED	RELEASED
NOTE(1) R/T : ROOM TEMPERATURE FOR REFERENCE ONLY Subject to change without notice Unless otherwise specified, refer to JIS C 5402.		<i>S. Kawanishi</i> '06.01.07	<i>D. Matsume</i> '06.01.19	<i>E. Kurii</i> '06.01.19	<i>M. Sato</i> '06.01.19	

Note QT:Qualification Test AT:Assurance Test ×:Applicable Test

HRS HIROSE ELECTRIC CO., LTD.		SPECIFICATION SHEET	PART NO. KMC9BRD-6S (71)
CODE NO. (OLD) CL	DRAWING NO. ELC4-007871-71	CODE NO. CL110-0017-9-71	1/1

TO
R



1		2			3			4		
COUNT	DESCRIPTION OF REVISIONS	BY	CHKD	DATE	COUNT	DESCRIPTION OF REVISIONS	BY	CHKD	DATE	
△					△					
△					△					
△					△					

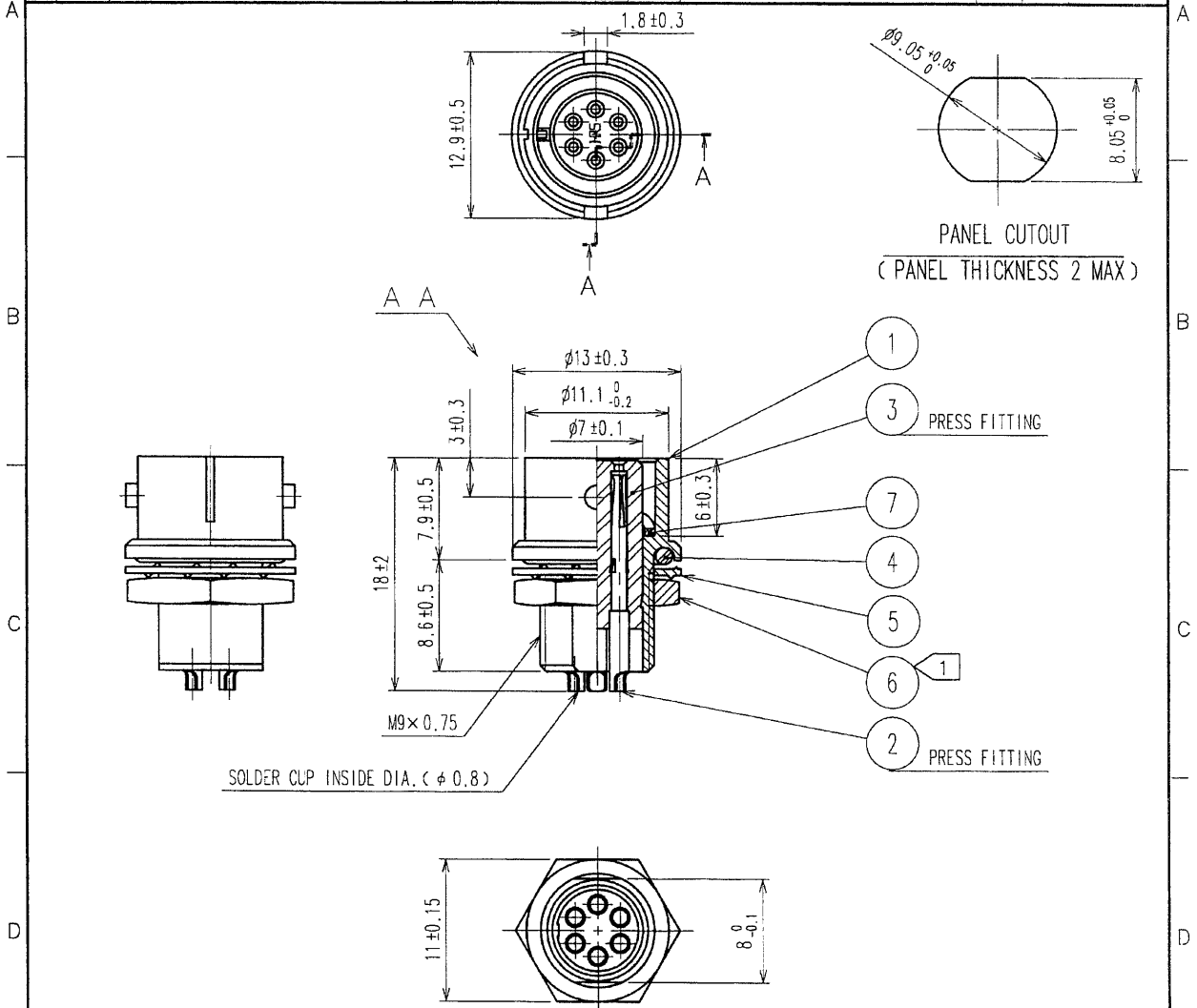

NOTE ① THE RECOMMENDED CRAMP TORQUE, REF.NO. ⑥: 1.5-2.0 N·m
 LOCTITE 242, LOCTITE OR EQUIVALENT IS RECOMMENDED TO
 PREVENT REF.NO. ⑥ FROM LOOSEING.

3	POLYACETAL	(BLACK)	2	BERYLLIUM COPPER	NICKEL PLATING
2	PHOSPHOR BRONZE	GOLD PLATING 2μ m min. NICKEL UNDER PLATING 3μ m min.	2	STEEL	NICKEL PLATING
1	ZINC ALLOY	MATTE FINISH NICKEL PLATED	5	STEEL	NICKEL PLATING
			4	CR	(BLACK)
NO.	MATERIAL	FINISH, REMARKS	NO.	MATERIAL	FINISH, REMARKS

CODE NO. (OLD)
CL

DRAWN

DESIGNED

CHECKED

APPROVED

RELEASED

FOR REFERENCE ONLY

Subject to change without notice

J. Kunita
06-01-19

D. Matsume
06-01-19

E. Kunita
06-01-19

M. Sato
06-01-19



SCALE
2 : 1

DRAWING NO.

EDC4-007871-71

PART NO.

KMC9BRD-6S(71)

UNITS
mm

HRS

HIROSE ELECTRIC CO., LTD.

CODE NO.

CL110-0017-9-71

1
1

TO
R