



MD CONNECTOR

Miniature circular connectors



The extremely compact MD miniature circular connector has an outside diameter roughly half that of conventional circular DIN connectors. The connector's contact exclusively designed by JST dramatically reduces assembly time while improving contact reliability. The MD connector's shielding is superb. All you need to do is crimp the connector ground clip over the cable's braided shielding wire. Simple and reliable, JST's MD connector is well suited for the production of high-density office automation equipments as well as audio and video products.

Standards

Recognized E60389

Certified LR20812

Shielding effect

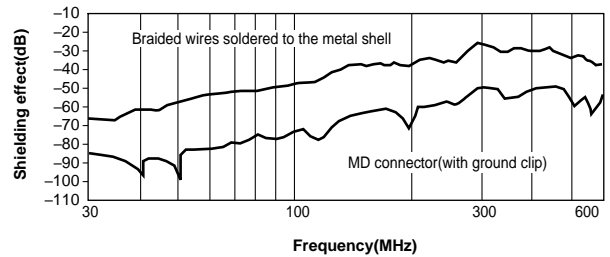

•The shielding effect differs depending on the wire specifications.

* Contact JST if Lead-Free product is required.

* Refer to "General Instruction and Notice when using Terminals and Connectors" at the end of this catalog.

* Contact JST for details.

MD CONNECTOR

PLUG

Straight type plug

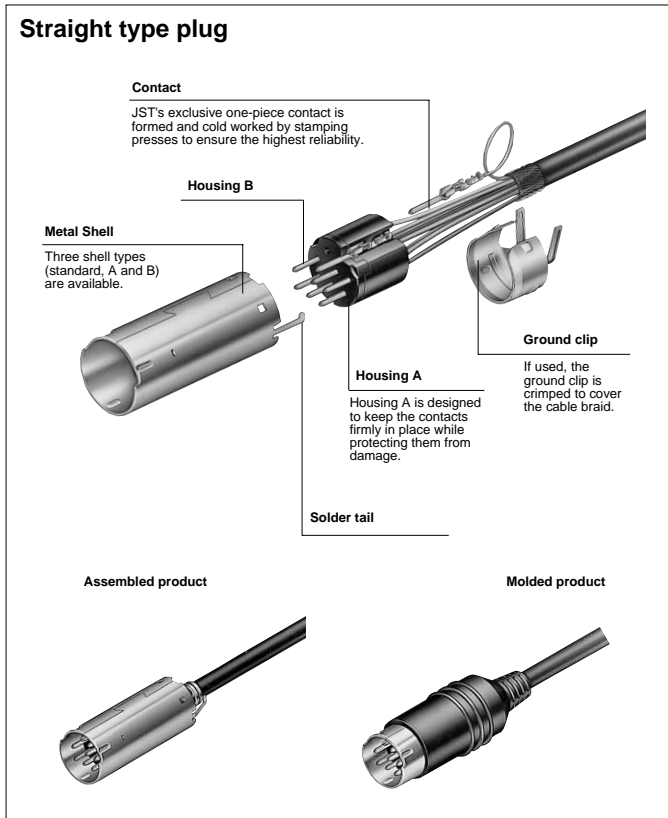

Side entry type plug

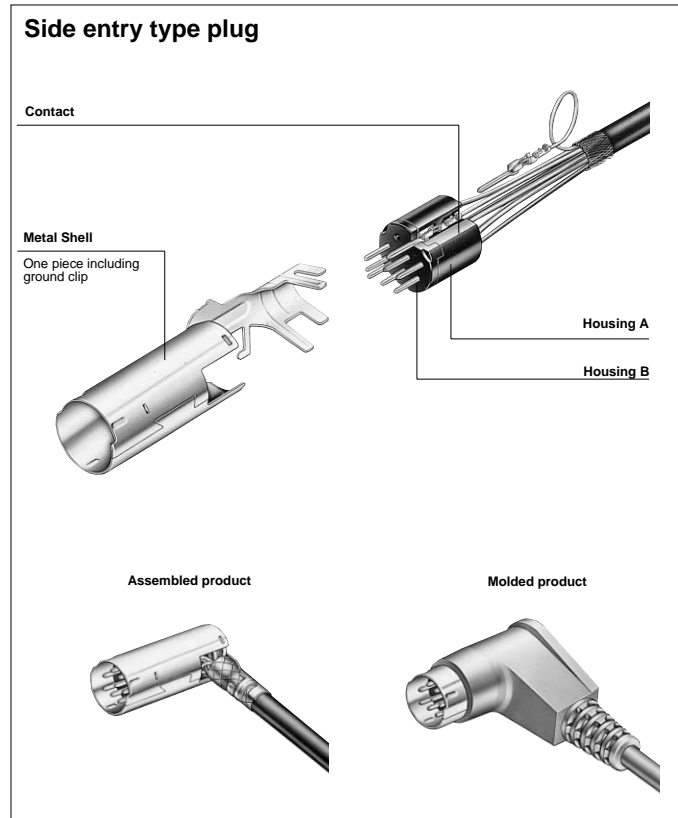

Features

- **Crimp contact with integral construction for improved reliability**

JST's exclusive one-piece construction of the pin and crimping section not only enhances the connection's reliability but also substantially improves productivity and efficiency by eliminating the need for soldering. Little force is required to insert the contact into the housing. Even a wire as thin as AWG #30 can be inserted easily by hand.

- **Easy assembly without using special tools**

Other than crimping tools, no special tools are required to assemble the connector. Simply install the contacts, housing, ground clip and metal shell in that order. This makes it possible to greatly increase assembly efficiency, resulting in significant reductions in total cost.

- **Simple braid-to-connector assembly and effective EMI protection**

Because the ground clip is crimped to the cable braid, no soldering is required. While securely holding the cable, the ground clip also ensures the integrity of the grounded circuit. This is a critical factor in reducing noise. The shielding effect of this method is approximately 20dB greater than that obtained by the conventional method of bundling and soldering cable braid to the metal shell.

Specifications

Materials

Part name	Material and Finish
Contact	Phosphor bronze, nickel-undercoated Mating section: gold-plated Crimping section: tin-plated Phosphor bronze, copper-undercoated, tin/lead-plated Phosphor bronze, nickel-undercoated silver-plated
Housing A, B	PBT, UL94V-0, black
Metal shell	Mild steel, nickel-plated
Ground clip	Brass, nickel-plated

Characteristics

Current rating	1.0A, AC, DC (using AWG #26)
Voltage rating	50V, AC, DC
Temperature range	-25°C to +85°C (including temperature rise in applying electrical current)
Contact resistance	Initial value: 100mΩ max. After environmental testing: 300mΩ max.
Insulation resistance	50MΩ min.
Withstanding voltage	500V AC/minute
Applicable wire	AWG #30 to #24

Plug contact

Model number identification

• Series name	MD - S	P	2	2	40
• Product from: S ... Chain, B ... Loose piece					
• Type of contact: P ... Plug contact					
• Applicable wire: 1 ... AWG #26 to #24 2 ... AWG #30 to #26					
• Material: 2 ... Phosphor bronze					
• Finish					
40 ... Gold-plated (flash)					
44 ... 0.76 micron(30 micro-inch) gold-plated					
45 ... 1.3 micron(51 micro-inch) gold-plated					
70 ... Silver-plated					
90 ... Tin-plated					

*Contact JST for details.

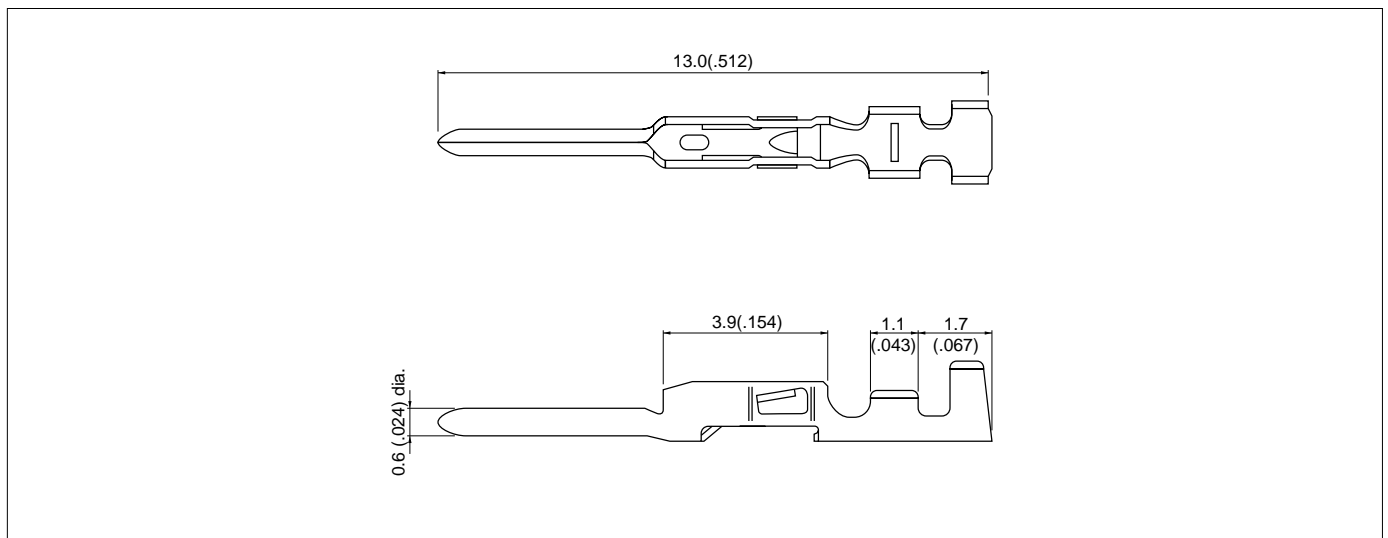

Model No.			Applicable wire			Q'ty / reel
Gold-plated (flash)	Silver-plated	Tin-plated	mm ²	AWG #	Insulation O.D. mm(in.)	
MD-SP2240	MD-SP2270	MD-SP2290	0.06 to 0.13	30 to 26	0.7 to 1.1(.028 to .043)	10,000
MD-SP1240	MD-SP1270	MD-SP1290	0.13 to 0.2	26 to 24	1.0 to 1.2(.039 to .047)	10,000

MD CONNECTOR

Housing

Housing A

(With 4 to 8 circuits)

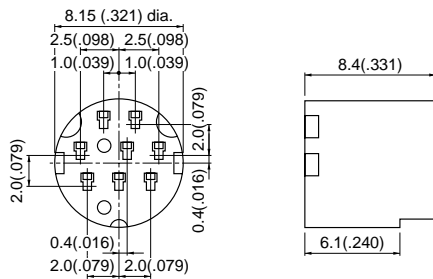

(With 9 circuits)

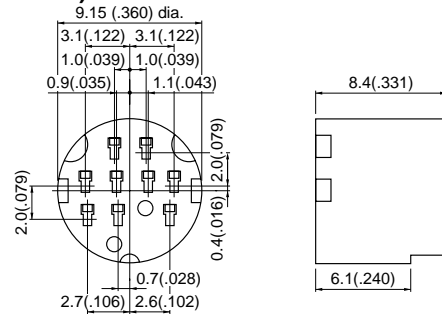

Housing B

(With 4 circuits)

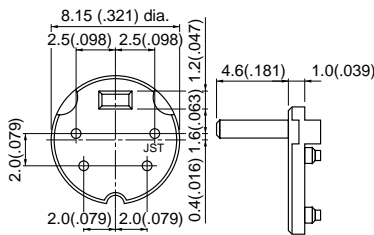

(With 5 circuits)

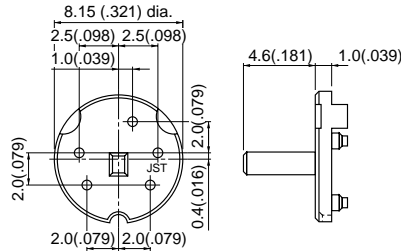

(With 6 circuits)

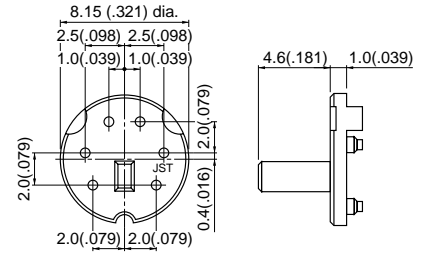

(With 8 circuits)

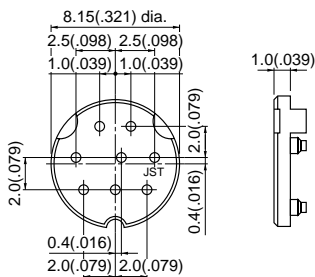

(With 9 circuits)

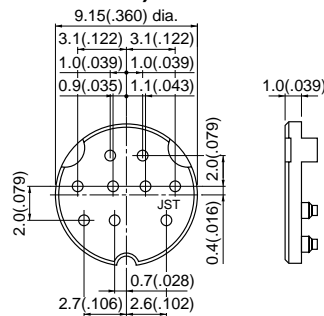

Combined housings A and B

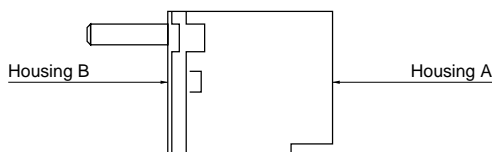

Housing A is used with housing B. Housing B must have the same number of orifices as there will be contacts in the connector. However, housing A can have a greater number of cavities (but never less). Thus in applications in which a user may require MD connectors with different pin counts, only one kind of "A" housing needs to be inventoried - the one with the highest pin count. For more details regarding such combinations, contact JST.

Circuits	Model No.		Q'ty / box
	Housing A	Housing B	
4	MD-PI4A	MD-PI4B	1,000
5	—	MD-PI5B	1,000
6	MD-PI6A	MD-PI6B	1,000
8	MD-PI8A	MD-PI8B	1,000
9	MD-PI9A	MD-PI9B	1,000

Note: MD-PI5B is not CSA certified.

Metal shell (straight type)

Standard type

(With 4 to 8 circuits)

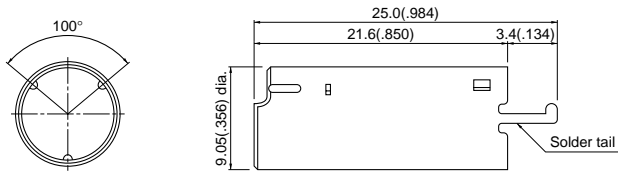

(With 9 circuits)

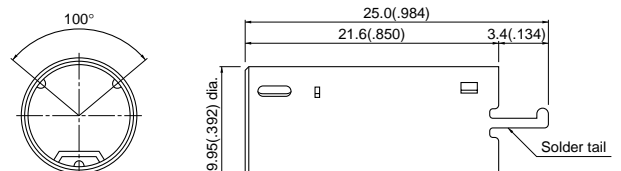

Type A

(features polarizing keys, usable with S-VHS connector)

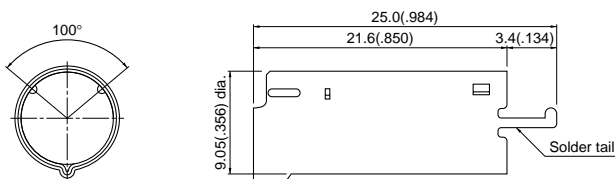

Type B

(features 4 polarizing keys, usable with having 8 circuits)

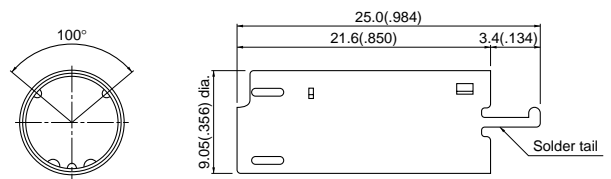

Circuits	Model No.						Q'ty / box
	Standard		Type A (features three polarizing keys)		Type B (features 4 polarizing keys ...8 circuits only)		
	With solder tail	Without solder tail	With solder tail	Without solder tail	With solder tail	Without solder tail	
4 to 8	MD-PS8T	*MD-PS8T1	*MD-PS8AT	*MD-PS8AT1	*MD-PS8BT	*MD-PS8BT1	750
9	MD-PS9T	*MD-PS9T1	—	—	—	—	750

*Marked products are not CSA certified.

Ground clip

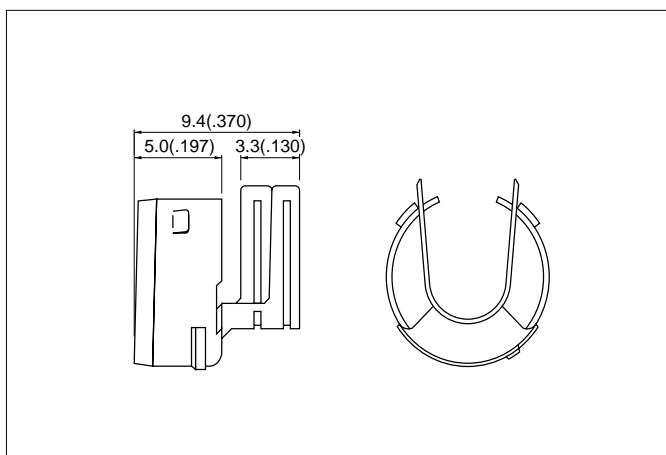

Circuits	Model No.	Applicable cable O.D. mm(in.)	Q'ty / reel
4 to 8	MD-PCC8T-S1	2.7(.106) to 3.8(.150)	1,000
	MD-PCC8T-S2	4.3(.169) to 5.5(.217)	1,000
9	MD-PCC9T-S3	3.6(.142) to 4.8(.189)	1,000

MD CONNECTOR

Metal shell (side entry type)

Standard type

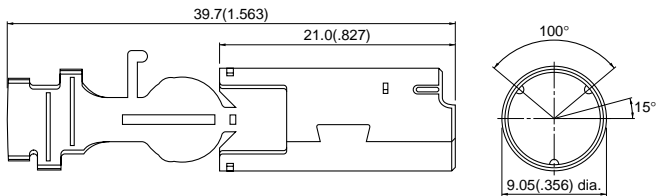

Type A

(features polarizing keys, usable with S-VHS connector)

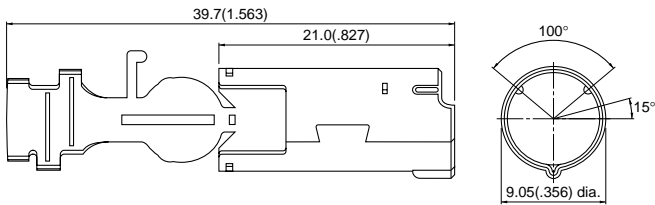

Type B

(features 4 polarizing keys, usable with housing having 8 circuits)

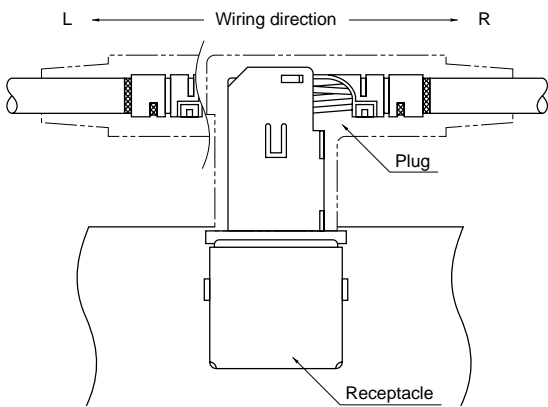
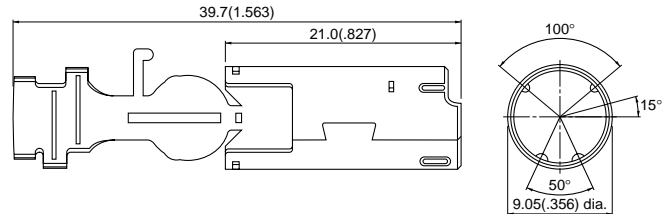

Viewing from the receptacle mounting side

Type	Circuits	Model number		Q'ty / box
		R	L	
Standard	4 to 8	MD-PS8SR	MD-PS8SL	500
A	4 to 8	MD-PS8ASR	—	500
B	8	MD-PS8BSR	—	500

Applicator for the semi-automatic press AP-K2N

Contact	Crimp applicator MKS-L		Compact crimp applicator MKS-LS-RG		Strip-crimp applicator MKS-SC
	with safety cover	without safety cover	with safety cover	without safety cover	with safety cover
MD-PCC8T-S1	APLMK MD-PCC8T-S1	APLNC MD-PCC8T-S1	—	—	—
MD-PCC8T-S2	APLMK MD-PCC8T-S2	APLNC MD-PCC8T-S2	—	—	—
MD-PCC9T-S3	APLMK MD-PCC9T-S3	APLNC MD-PCC9T-S3	—	—	—
MD-PS8SL	—	—	APLMKLS MD-PS8SR	APLLSNC MD-PS8SR	—
MD-PS8ASR	—	—	APLMKLS MD-PS8SR	APLLSNC MD-PS8SR	—
MD-PS8BSR	—	—	APLMKLS MD-PS8SR	APLLSNC MD-PS8SR	—
MD-PS8SR	—	—	APLMKLS MD-PS8SR	APLLSNC MD-PS8SR	—
MD-SP12**	APLMK MD-SP12	APLNC MD-SP12	—	—	APLSC MD-SP12
MD-SP22**	APLMK MD-SP22	APLNC MD-SP22	—	—	APLSC MD-SP22

RECEPTACLE (through-hole type)

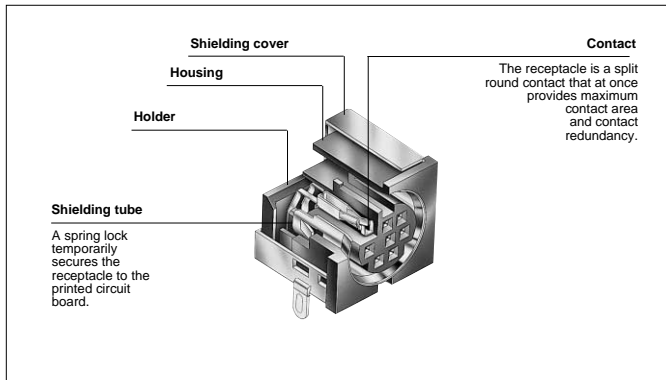

Features

- **Split round contact provides maximum contact area and contact redundancy**

The receptacle contact is split to insure redundant connection and is cylindrically shaped to provide maximum contact mating area. The result is a highly reliable connection to the mating pin. This superb contact performance is maintained even after many mating and unmating cycles.

- **Flange construction**

The flange construction allows the receptacle to be secured on the equipment chassis with screws, ensuring more reliable electrical connection.

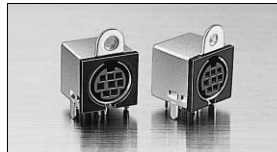

Standard type with flange shielding cover

(Standard type/Type B)

- **Compact, high-density design**

This receptacle has a low profile with a mounting height of just 12.8mm (.504") and width of 14.0mm (.551"). It takes up little space on the printed circuit board, allowing high-density product design.

- **Spring locks make it easy to temporarily secure receptacles to printed circuit boards for soldering**

The shielding tubes are equipped with spring locks which can be used to temporarily secure the receptacles to printed circuit boards. This prevents the receptacles from moving and ensures reliable soldering.

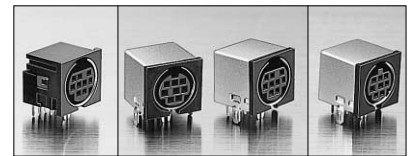

Standard type without shielding cover (left)
Standard type with shielding cover (center)
Type B (applicable to Type B plug) (right)

(Front shielding type)

- **Front shielding construction**

A metal shielding cover integrating the connection part which connects to the plug's shell is used. Because there is no gap between the receptacle and the plug, this construction prevents the entry of space conductive noise.

- **Effective shielding**

With the front shielding construction and the flange construction, the shielding effect is improved by about 15 dB over the conventional models.



Front shielding type receptacle

Specifications

Materials

Part name	Material and Finish
Contact	Phosphor bronze, nickel-undercoated Mating section: gold-plated Solder tail: tin/lead-plated Phosphor bronze, nickel-undercoated silver-plated Phosphor bronze, copper-undercoated, tin-plated
Housing / Holder	PBT, UL94V-0

Characteristics

Current rating	1.0A, AC, DC
Voltage rating	50V, AC, DC
Temperature range	-25°C to +85°C (including temperature rise in applying electrical current)
Contact resistance	Initial value: 100mΩ max. After environmental testing: 300mΩ max.
Withstanding voltage	500V AC/minute
Applicable PC board thickness	1.6mm(.063")

[Standard type/Type B]

Shielding tube	Brass, nickel-plated (*note)
Shielding cover	Brass, copper-undercoat, tin-plated

[Front shielding Type]

Shielding cover	Brass, nickel-plated (*note)
-----------------	------------------------------

Note: Use soldering flux that is suitable for nickel-plating. Tin plated version is also available.

Model number identification

Series name	MD - S 8 0 00 B - 10
Product name: S ... Receptacle	
Circuits: 4, 5, 6, 7, 8, 9	
Shielding cover: 0 ... Without shielding cover 1 ... With shielding cover 3 ... With front shielding cover	
Flange: 00 ... Without flange 30 ... With flange 50 ... With top flange with nuts	
Type B indication B ... Type B (Applicable to Type B plug) Blank...Standard type (Applicable to Standard and Type A plugs) ...Front shielding type (Applicable to Standard and Type plugs)	
Finish 10 ... Gold-plated (flash) 13 ... 0.4micron(16micro-inch) gold-plated 14 ... 0.76micron(30micro-inch) gold-plated 70 ... Silver-plated 90 ... Tin-plated	

Note: Contact JST for special plating requirements.

MD CONNECTOR

Standard type/Type B

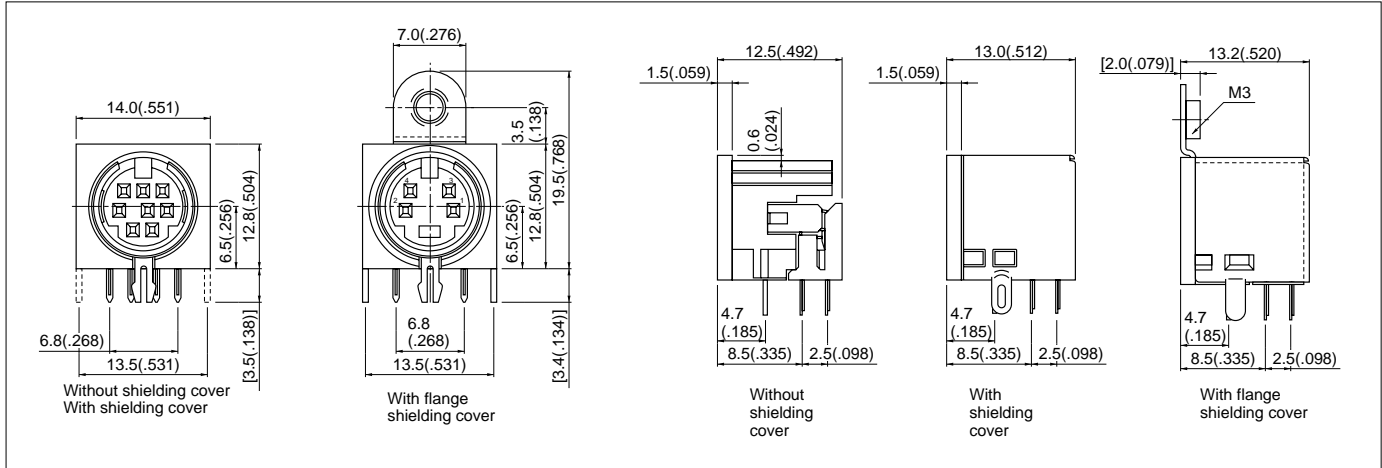

• Standard type: Without shielding cover

Circuits	Model No.			Q'ty / box
	Gold-plated (flash) receptacle	Silver-plated receptacle	Tin-plated receptacle	
4	MD-S4000-10	MD-S4000-70	MD-S4000-90	200
5	MD-S5000-10	MD-S5000-70	MD-S5000-90	200
6	MD-S6000-10	MD-S6000-70	MD-S6000-90	200
7	MD-S7000-10	MD-S7000-70	MD-S7000-90	200
8	MD-S8000-10	MD-S8000-70	MD-S8000-90	200
9	MD-S9000-10	MD-S9000-70	MD-S9000-90	200

• Standard type: With flange shielding cover

Circuits	Model No.			Q'ty / box
	Gold-plated (flash) receptacle	Silver-plated receptacle	Tin-plated receptacle	
4	MD-S4130-10	MD-S4130-70	MD-S4130-90	200
5	MD-S5130-10	MD-S5130-70	MD-S5130-90	200
6	MD-S6130-10	MD-S6130-70	MD-S6130-90	200
7	MD-S7130-10	MD-S7130-70	MD-S7130-90	200
8	MD-S8130-10	MD-S8130-70	MD-S8130-90	200

• Standard type: With shielding cover

Circuits	Model No.			Q'ty / box
	Gold-plated (flash) receptacle	Silver-plated receptacle	Tin-plated receptacle	
4	MD-S4100-10	MD-S4100-70	MD-S4100-90	200
5	MD-S5100-10	MD-S5100-70	MD-S5100-90	200
6	MD-S6100-10	MD-S6100-70	MD-S6100-90	200
7	MD-S7100-10	MD-S7100-70	MD-S7100-90	200
8	MD-S8100-10	MD-S8100-70	MD-S8100-90	200
9	MD-S9100-10	MD-S9100-70	MD-S9100-90	200

• Type B: Without shielding cover

Circuits	Model No.			Q'ty / box
	Gold-plated (flash) receptacle	Silver-plated receptacle	Tin-plated receptacle	
8	MD-S8000B-10	MD-S8000B-70	MD-S8000B-90	200

• Type B: With shielding cover

Circuits	Model No.			Q'ty / box
	Gold-plated (flash) receptacle	Silver-plated receptacle	Tin-plated receptacle	
8	MD-S8100B-10	MD-S8100B-70	MD-S8100B-90	200

• Type B: With flange shielding cover

Circuits	Model No.			Q'ty / box
	Gold-plated (flash) receptacle	Silver-plated receptacle	Tin-plated receptacle	
8	MD-S8130B-10	MD-S8130B-70	MD-S8130B-90	200

• Front shielding type

Circuits	Model No.			Q'ty / box
	Gold-plated (flash) receptacle	Silver-plated receptacle	Tin-plated receptacle	
4	MD-S4350-10	MD-S4350-70	MD-S4350-90	200
5	MD-S5350-10	MD-S5350-70	MD-S5350-90	200
6	MD-S6350-10	MD-S6350-70	MD-S6350-90	200
8	MD-S8350-10	MD-S8350-70	MD-S8350-90	200

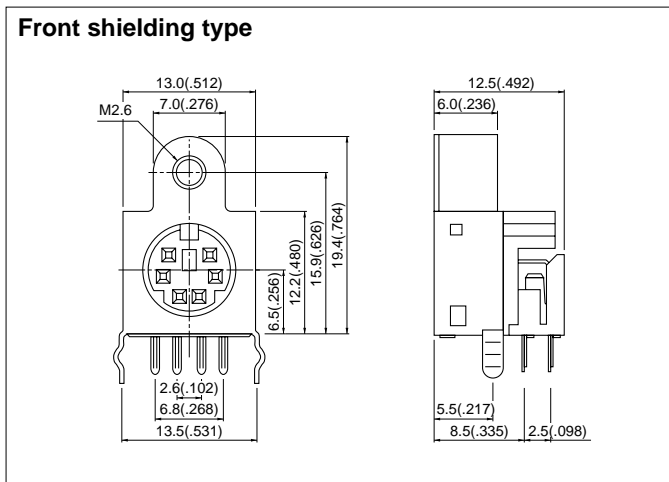

PC board layout

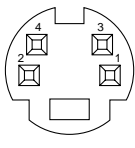
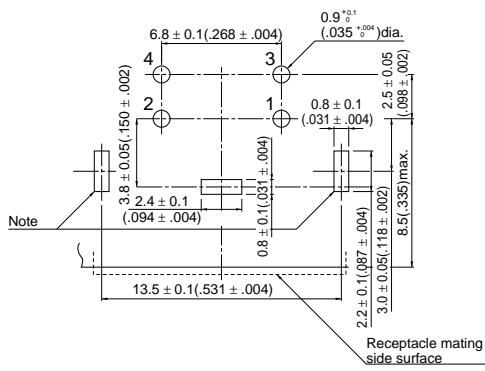
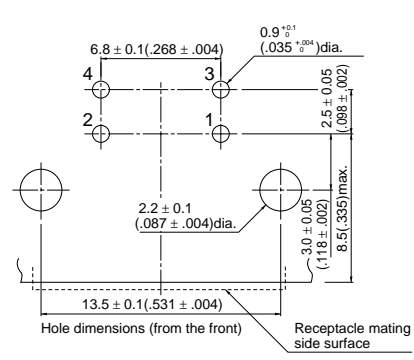
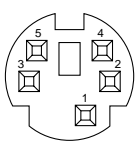
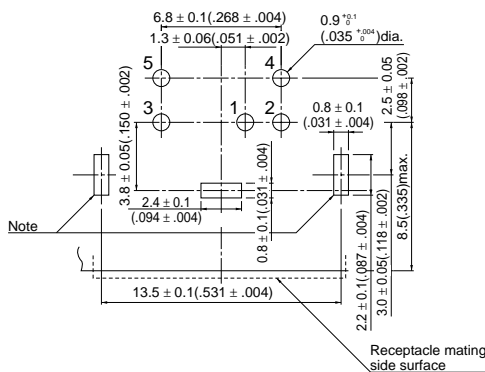
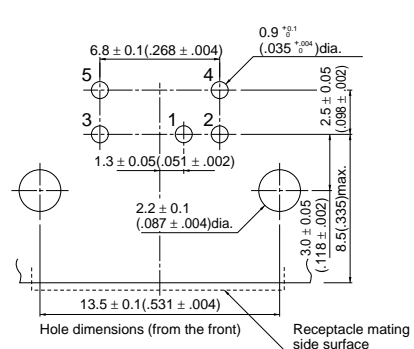
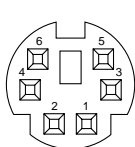
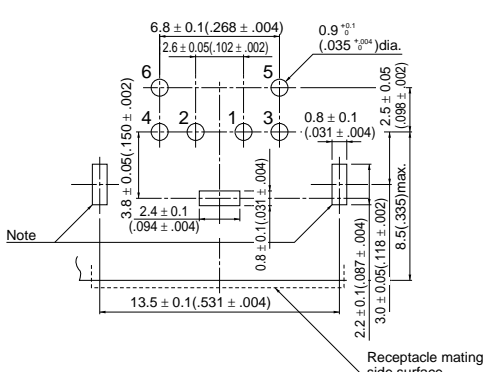
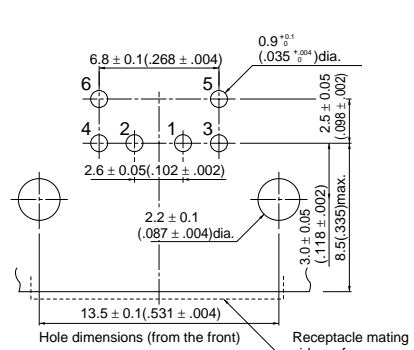
Layout Circuits	Mating section layout	PC board layout (viewed from component side)	
		Standard and Type B	Front shielding type
4		 <p>Note: The two holes are necessary when installing a shielding cover.</p>	 <p>Hole dimensions (from the front)</p> <p>Receptacle mating side surface</p>
5		 <p>Note: The two holes are necessary when installing a shielding cover.</p>	 <p>Hole dimensions (from the front)</p> <p>Receptacle mating side surface</p>
6		 <p>Note: The two holes are necessary when installing a shielding cover.</p>	 <p>Hole dimensions (from the front)</p> <p>Receptacle mating side surface</p>

MD CONNECTOR

PC board layout

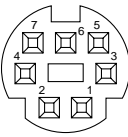
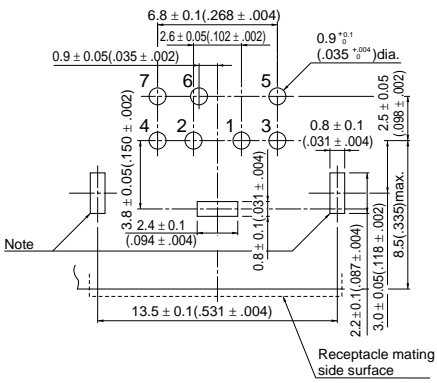
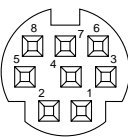
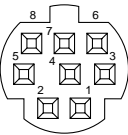
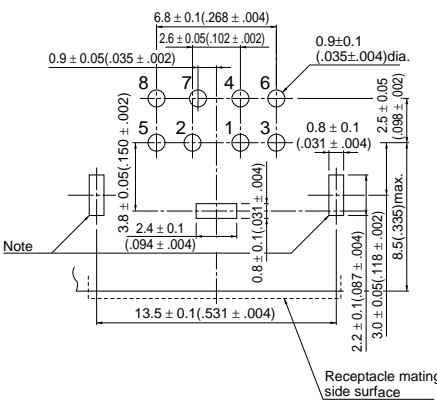
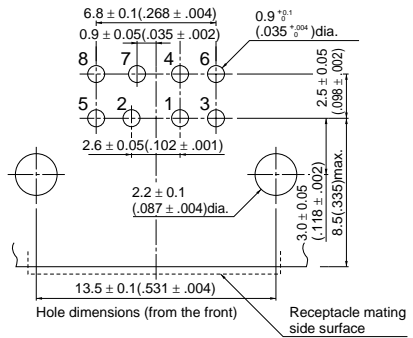
Layout Circuits	Mating section layout	PC board layout (viewed from component side)	
		Standard and Type B	Front shielding type
7		 <p>Note: The two holes are necessary when installing a shielding cover.</p>	
8	 (Type B) 	 <p>Note: The two holes are necessary when installing a shielding cover.</p>	 <p>Hole dimensions (from the front)</p> <p>Receptacle mating side surface</p>

PC board layout

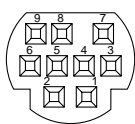
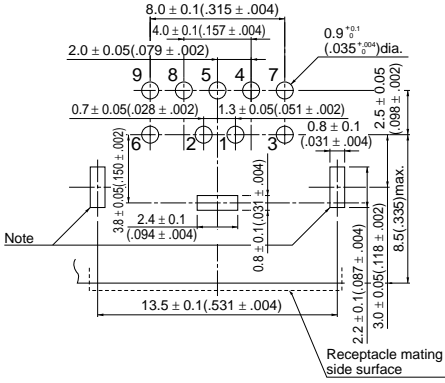
Layout Circuits	Mating section layout	PC board layout (viewed from component side)	
		Standard and Type B	Front shielding type
9		 <p>Note: The two holes are necessary when installing a shielding cover.</p>	

Note:

1. Tolerances are non-cumulative: $\pm 0.05\text{mm}(\pm .002")$ for all centers.
2. Hole dimensions differ depending on the kind of PC board and piercing method. The dimensions above should serve as a guideline. For details, contact JST.
3. The layout drawing is viewed from the receptacle mounting side.
4. When using a receptacle with shielding cover or with flange shielding cover, the pattern should be designed to connect the shielding cover and the shielding tube, if necessary. (No need for the front shielding cover.)

MD CONNECTOR

Assembly layout

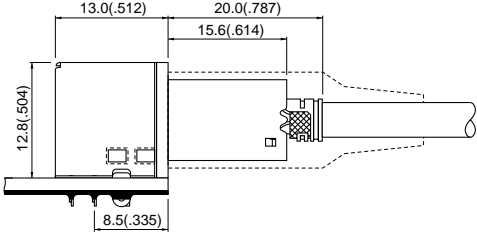
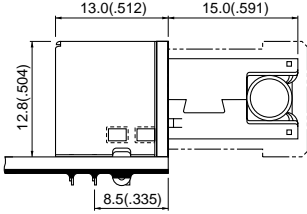
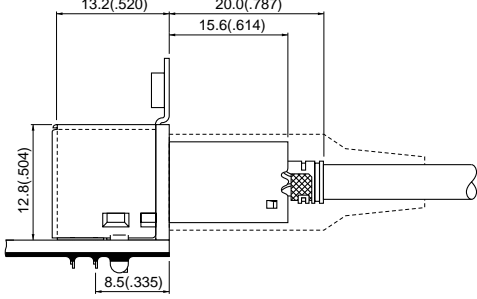
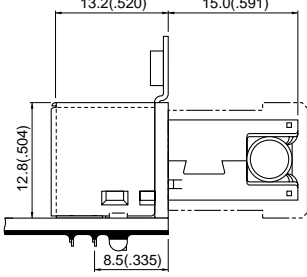
Plug Receptacle	Straight type	Side entry type
Standard type Type B With shielding cover		
Standard type Type B With flange shielding cover		
Front shielding type	