

THIS DRAWING IS UNPUBLISHED. RELEASED FOR PUBLICATION APR ,2003.
 © COPYRIGHT 2003 BY TYCO ELECTRONICS CORPORATION. ALL RIGHTS RESERVED.

LOC		DIST		REVISIONS			
E	B	P	LTR	DESCRIPTION	DATE	DWN	APVD
		E		ECR-08-029209	18NOV08	AM	NC

- NOTES:
- MATERIAL**
 HOUSING : THERMOPLASTIC, UL94V-0, BLACK
 CONTACTS : BRASS.
 SHELL : STEEL
 SCREW : BRASS.
 BOARD LOCK : BRASS.
 SCREW OF TORQUE : 5 Kg-cm MAX.
 - FINISH**
 CONTACT : 15µ" MIN.GOLD PLATING ON CONTACT AREA
 100µ" MIN. TIN-CU PLATING ON SOLDER TAILS
 50µ" MIN. NICKEL UNDERPLATED OVERALL
 SHELL : 60µ" MIN. TIN PLATING
 SCREW : 50µ" MIN. NICKEL PLATING.
 BOARD LOCK : 50µ" MIN. NICKEL PLATING.
 - CHARACTERISTICS**
 CURRENT RATING : 3A
 INSULATION RESISTANCE : 1000MOHMS MIN, 500VDC FOR 2MINS.
 TEMPERATURE RATING : -55DEGC ~ +105DEGC
 VOLTAGE RATING : 250VDC

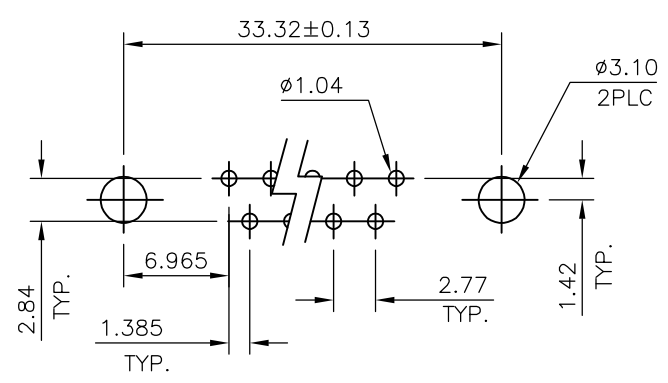
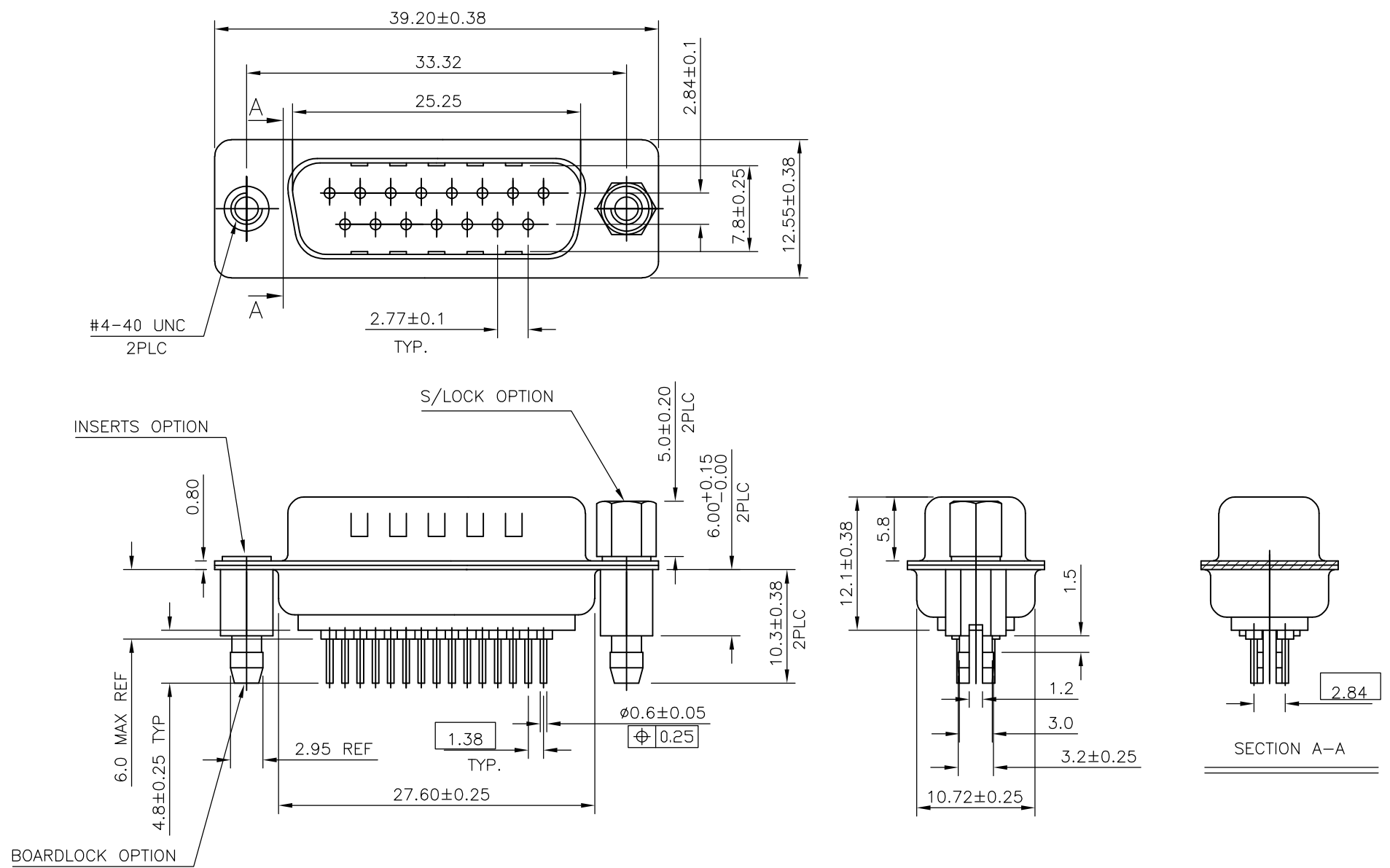

15W D PLG WITH B/L & M3 S/LOCK 15µ" GOLD	4-1634219-2
15W D PLG WITH B/L & 4-40 S/LOCK 15µ" GOLD	3-1634219-2
15W D PLG WITH B/L & M3 INSERTS 15µ" GOLD	2-1634219-2
15W D PLG WITH B/L & 4-40 INSERTS 15µ" GOLD	1-1634219-2
DESCRIPTION	TE PART No.

THIS DRAWING IS A CONTROLLED DOCUMENT.		DWN J.SANDWELL 10APR03	Tyco Electronics Corporation Stanmore, Middlesex, HA7 4RS	
DIMENSIONS: MM		CHK R.DYER 10APR03	NAME D-SUB HD20, VERTICAL, 15P PLUG CONNECTOR	
TOLERANCES UNLESS OTHERWISE SPECIFIED:		APVD F.WHEELER-KING 10APR03	SIZE A3 CAGE CODE 00779 DRAWING NO G-1634219	
0 PLC ± -		PRODUCT SPEC -	RESTRICTED TO -	
1 PLC ± 0.25		APPLICATION SPEC -	SCALE 2:1 SHEET 1 OF 2 REV E	
2 PLC ± 0.15		WEIGHT -	CUSTOMER DRAWING	
3 PLC ± -				
4 PLC ± -				
ANGLES ± -				
FINISH -				

THIS DRAWING IS UNPUBLISHED.

RELEASED FOR PUBLICATION APR , 2003.

© COPYRIGHT 2003 BY TYCO ELECTRONICS CORPORATION. ALL RIGHTS RESERVED.

LOC	DIST	REVISIONS					
E	B	P	LTR	DESCRIPTION	DATE	DWN	APVD
			-	SEE SHEET 1	-	-	-

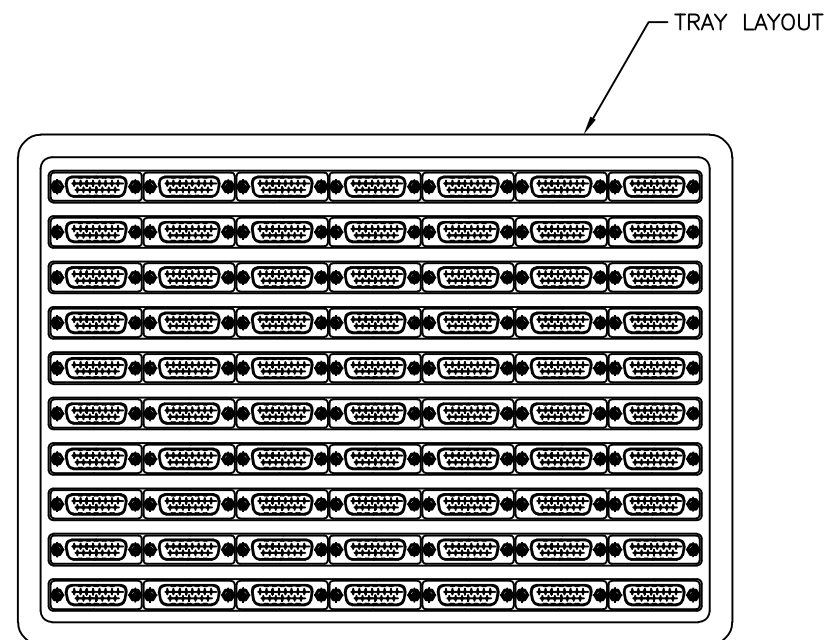
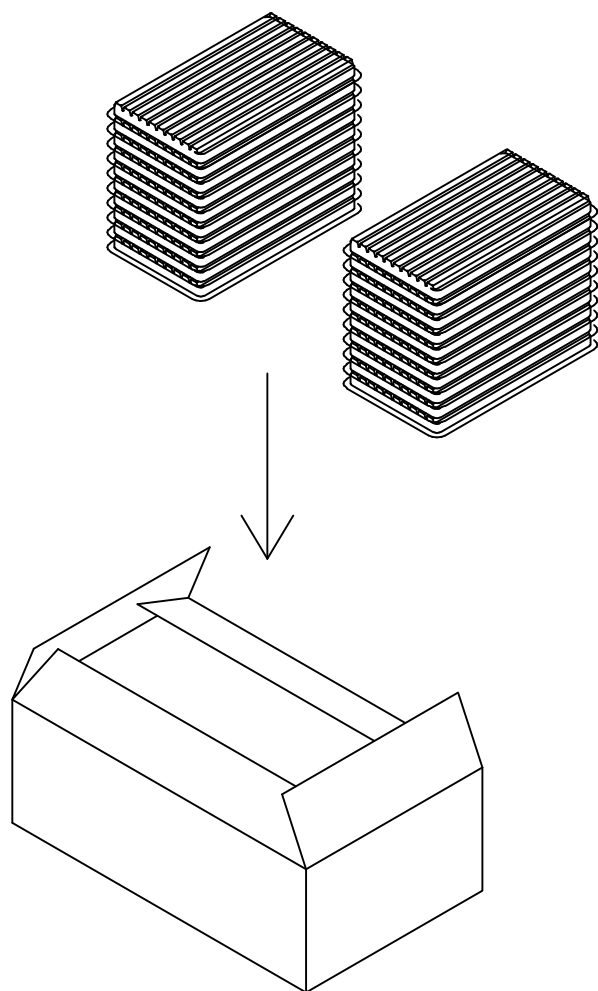
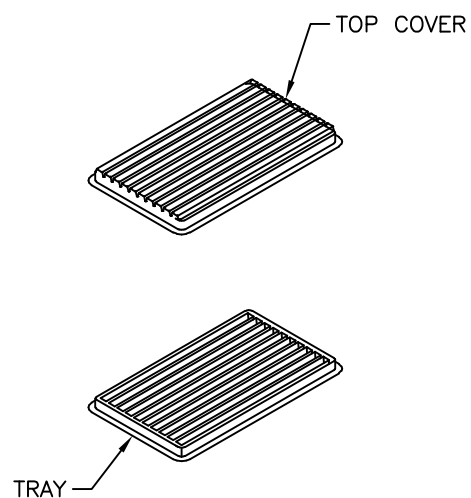

NOTES:

MATERIAL

- 1. TRAY: PVC
- 2. SHIPPING CARTON: CORRUGATED FIBERBOARD

DIMENSIONS

- 1. TRAY: L=310, W=230, H=21
- 2. SHIPPING CARTON: L=465, W=320, H=230

QUANTITY

- 70 PCS/TRAY
- 20 TRAY/SHIPPING CARTON

THIS DRAWING IS A CONTROLLED DOCUMENT.		DWN J.SANDWELL 10APR03	Tyco Electronics Corporation Stanmore, Middlesex, HA7 4RS	
DIMENSIONS: MM		CHK R.DYER 10APR03	NAME D-SUB HD20, VERTICAL, 15P PLUG CONNECTOR	
TOLERANCES UNLESS OTHERWISE SPECIFIED:		APVD F.WHEELER-KING 10APR03	PRODUCT SPEC -	
0 PLC ± -		APPLICATION SPEC -		
1 PLC ± 0.25		SIZE A3		
2 PLC ± 0.15		CAGE CODE 00779		
3 PLC ± -		DRAWING NO C-1634219		
4 PLC ± -		RESTRICTED TO -		
ANGLES ± -		SCALE NTS		
MATERIAL -		SHEET 2 OF 2		
FINISH -		REV E		
		CUSTOMER DRAWING		