

THIS DRAWING IS UNPUBLISHED. RELEASED FOR PUBLICATION APR ,2003.
 © COPYRIGHT 2003 BY TYCO ELECTRONICS CORPORATION. ALL RIGHTS RESERVED.

LOC	DIST	REVISIONS					
E	B	P	LTR	DESCRIPTION	DATE	DWN	APVD
		E		ECR-08-029209	18NOV08	AM	NC

- NOTES:
- MATERIAL**
 HOUSING : THERMOPLASTIC, UL94V-0, BLACK
 CONTACTS : BRASS.
 SHELL : STEEL
 SCREW : BRASS.
 BOARD LOCK : BRASS.
 SCREW OF TORQUE : 5 Kg-cm MAX.
 - FINISH**
 CONTACT : 15µ" MIN.GOLD PLATING ON CONTACT AREA
 100µ" MIN. TIN-CU PLATING ON SOLDER TAILS
 50µ" MIN. NICKEL UNDERPLATED OVERALL
 SHELL : 60µ" MIN. TIN PLATING
 SCREW : 50µ" MIN. NICKEL PLATING.
 BOARD LOCK : 50µ" MIN. NICKEL PLATING.
 - CHARACTERISTICS**
 CURRENT RATING : 3A
 INSULATION RESISTANCE : 1000MOHMS MIN, 500VDC FOR 2MINS.
 TEMPERATURE RATING : -55DEGC ~ +105DEGC
 VOLTAGE RATING : 250VDC

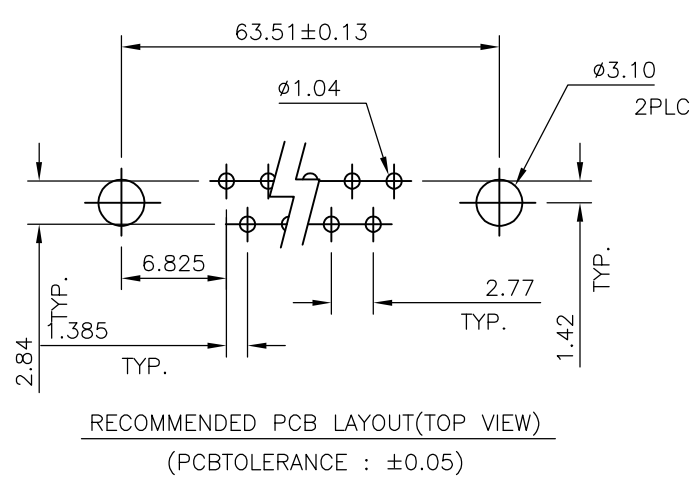
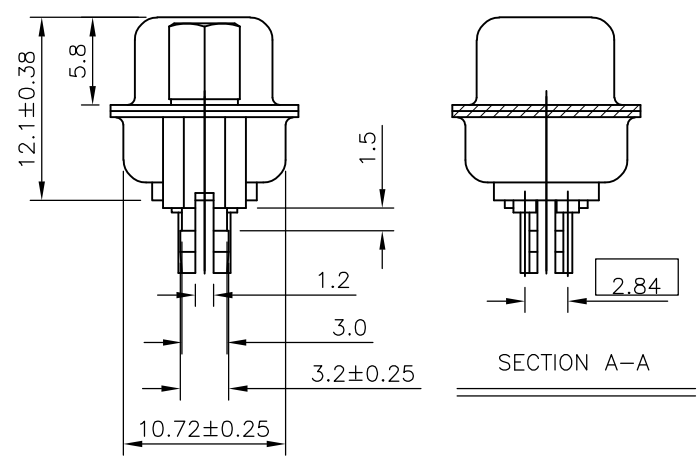
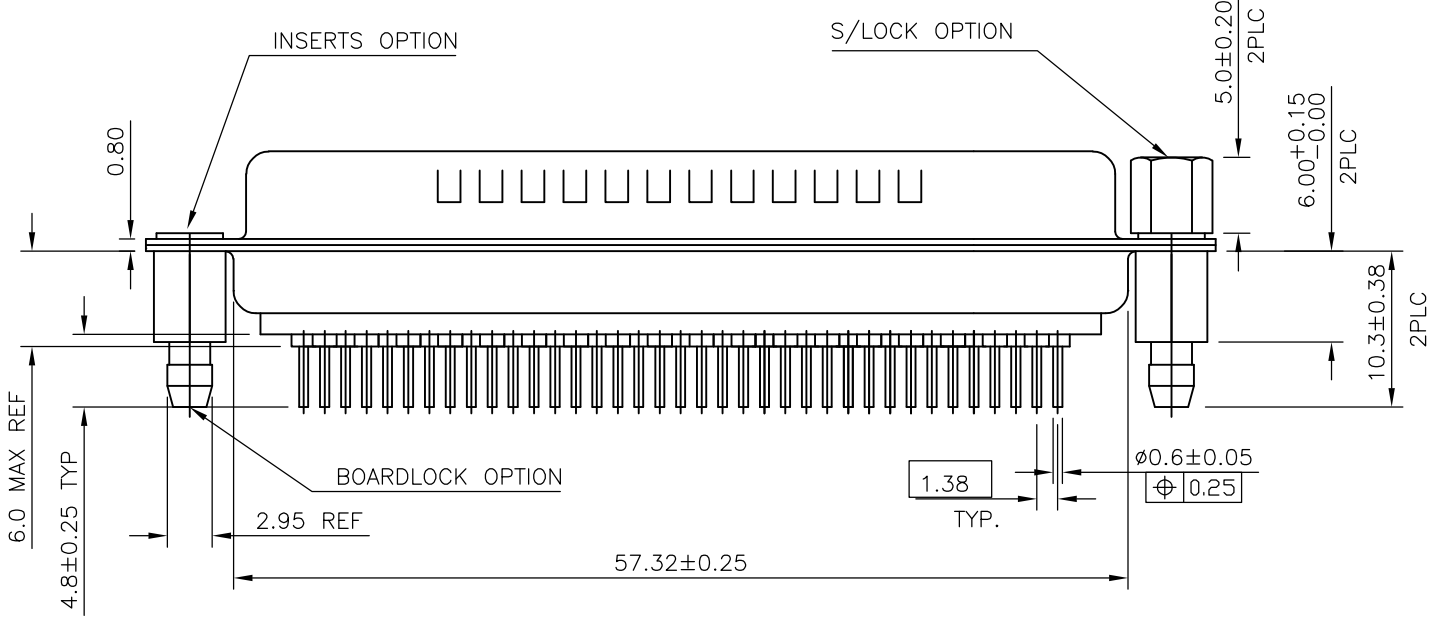
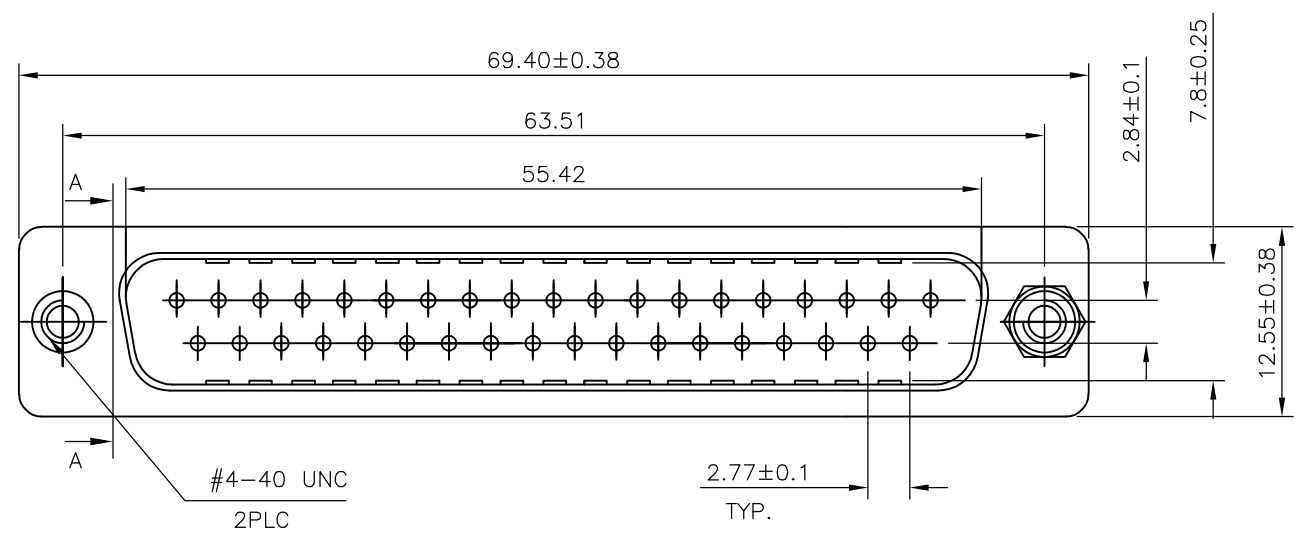

37W D PLG WITH B/L & M3 S/LOCK 15µ" GOLD	4-1634221-2
37W D PLG WITH B/L & 4-40 S/LOCK 15µ" GOLD	3-1634221-2
37W D PLG WITH B/L & M3 INSERTS 15µ" GOLD	2-1634221-2
37W D PLG WITH B/L & 4-40 INSERTS 15µ" GOLD	1-1634221-2
DESCRIPTION	TE PART No.

THIS DRAWING IS A CONTROLLED DOCUMENT.		DWN J.SANDWELL 10APR03	Tyco Electronics Corporation Stanmore, Middlesex, HA7 4RS	
DIMENSIONS: MM		CHK R.DYER 10APR03		
TOLERANCES UNLESS OTHERWISE SPECIFIED:		APVD F.WHEELER-KING 10APR03	NAME D-SUB HD20, VERTICAL, 37P PLUG CONNECTOR	
0 PLC ± -		PRODUCT SPEC -	SIZE A3	
1 PLC ± 0.25		APPLICATION SPEC -	CAGE CODE 00779	DRAWING NO C-1634221
2 PLC ± .15		WEIGHT -	RESTRICTED TO -	
3 PLC ± -		CUSTOMER DRAWING	SCALE 2:1	SHEET 1 OF 2
4 PLC ± -			REV E	
ANGLES ± 3				
FINISH -				

THIS DRAWING IS UNPUBLISHED. RELEASED FOR PUBLICATION APR , 2003.

© COPYRIGHT 2003 BY TYCO ELECTRONICS CORPORATION. ALL RIGHTS RESERVED.

LOC	DIST	REVISIONS					
E	B	P	LTR	DESCRIPTION	DATE	DWN	APVD
			-	SEE SHEET 1	-	-	-

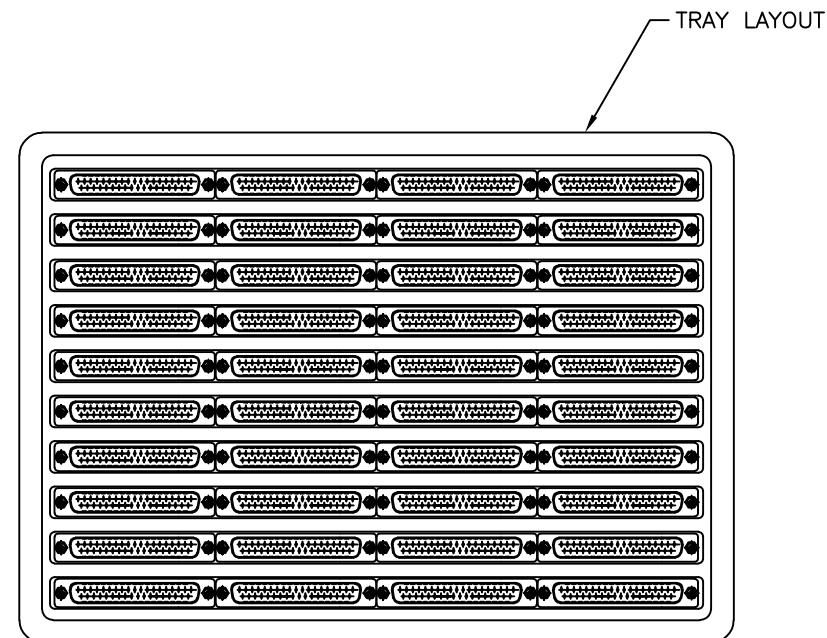
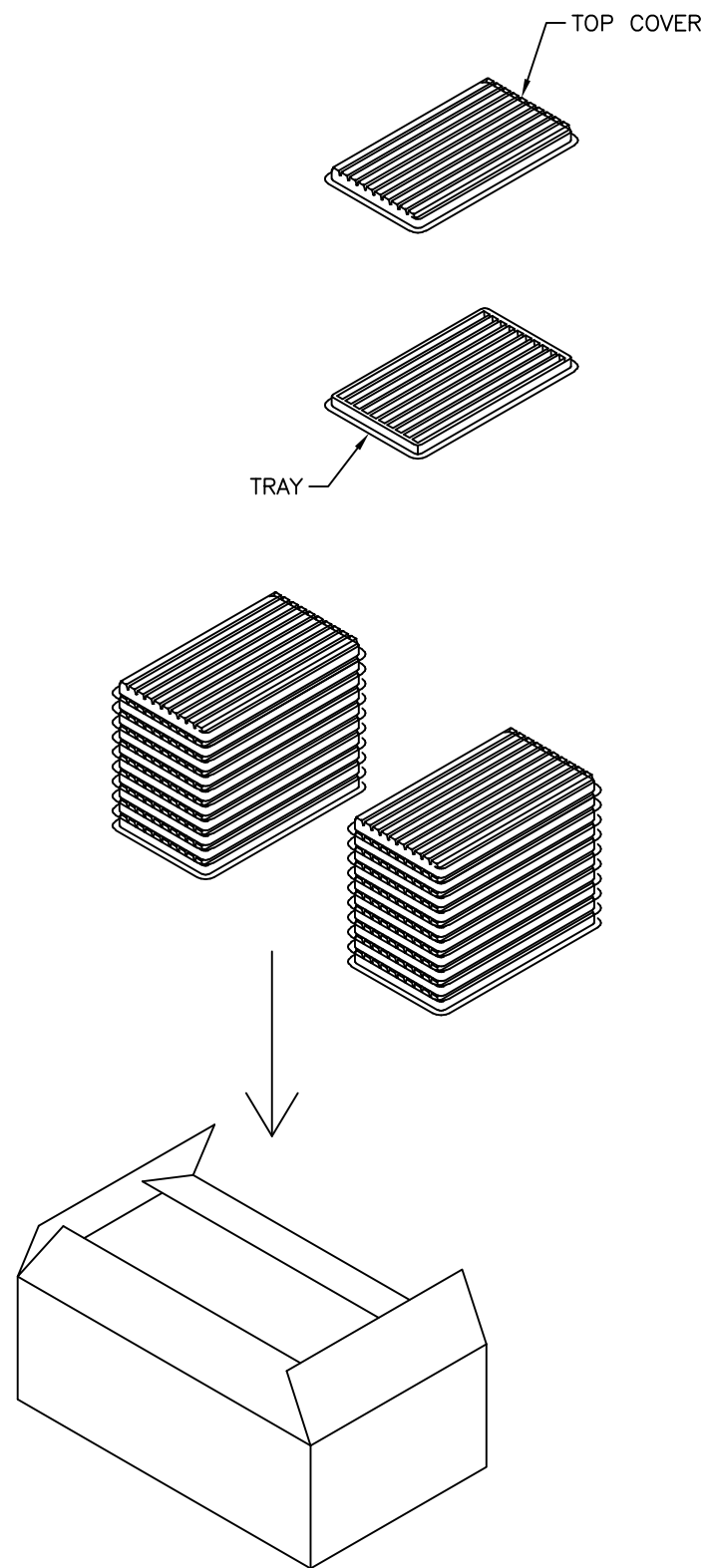

NOTES:

MATERIAL

- 1. TRAY: PVC
- 2. SHIPPING CARTON: CORRUGATED FIBERBOARD

DIMENSIONS

- 1. TRAY: L=310, W=230, H=21
- 2. SHIPPING CARTON: L=465, W=320, H=230

QUANTITY

- 40 PCS/TRAY
- 20 TRAY/SHIPPING CARTON

THIS DRAWING IS A CONTROLLED DOCUMENT.		DWN J.SANDWELL 10APR03	Tyco Electronics Corporation Stanmore, Middlesex, HA7 4RS													
DIMENSIONS: MM		CHK R.DYER 10APR03	NAME D-SUB HD20, VERTICAL, 37P PLUG CONNECTOR													
TOLERANCES UNLESS OTHERWISE SPECIFIED:		APVD F.WHEELER-KING 10APR03	PRODUCT SPEC -													
<table border="1"> <tr><td>0 PLC</td><td>± -</td></tr> <tr><td>1 PLC</td><td>± 0.25</td></tr> <tr><td>2 PLC</td><td>± .15</td></tr> <tr><td>3 PLC</td><td>± -</td></tr> <tr><td>4 PLC</td><td>± -</td></tr> <tr><td>ANGLES</td><td>± 3</td></tr> </table>		0 PLC	± -	1 PLC	± 0.25	2 PLC	± .15	3 PLC	± -	4 PLC	± -	ANGLES	± 3	APPLICATION SPEC -	SIZE A3	CAGE CODE 00779
0 PLC	± -															
1 PLC	± 0.25															
2 PLC	± .15															
3 PLC	± -															
4 PLC	± -															
ANGLES	± 3															
MATERIAL -	FINISH -	WEIGHT -	DRAWING NO C-1634221	RESTRICTED TO -												
CUSTOMER DRAWING			SCALE NTS	SHEET 2 OF 2												
			REV E													