

REVOLUTIONS		DATE	OWN	APPROV
DF	DO			
D	REV PER	0630-0561-01	12-01	CT DM

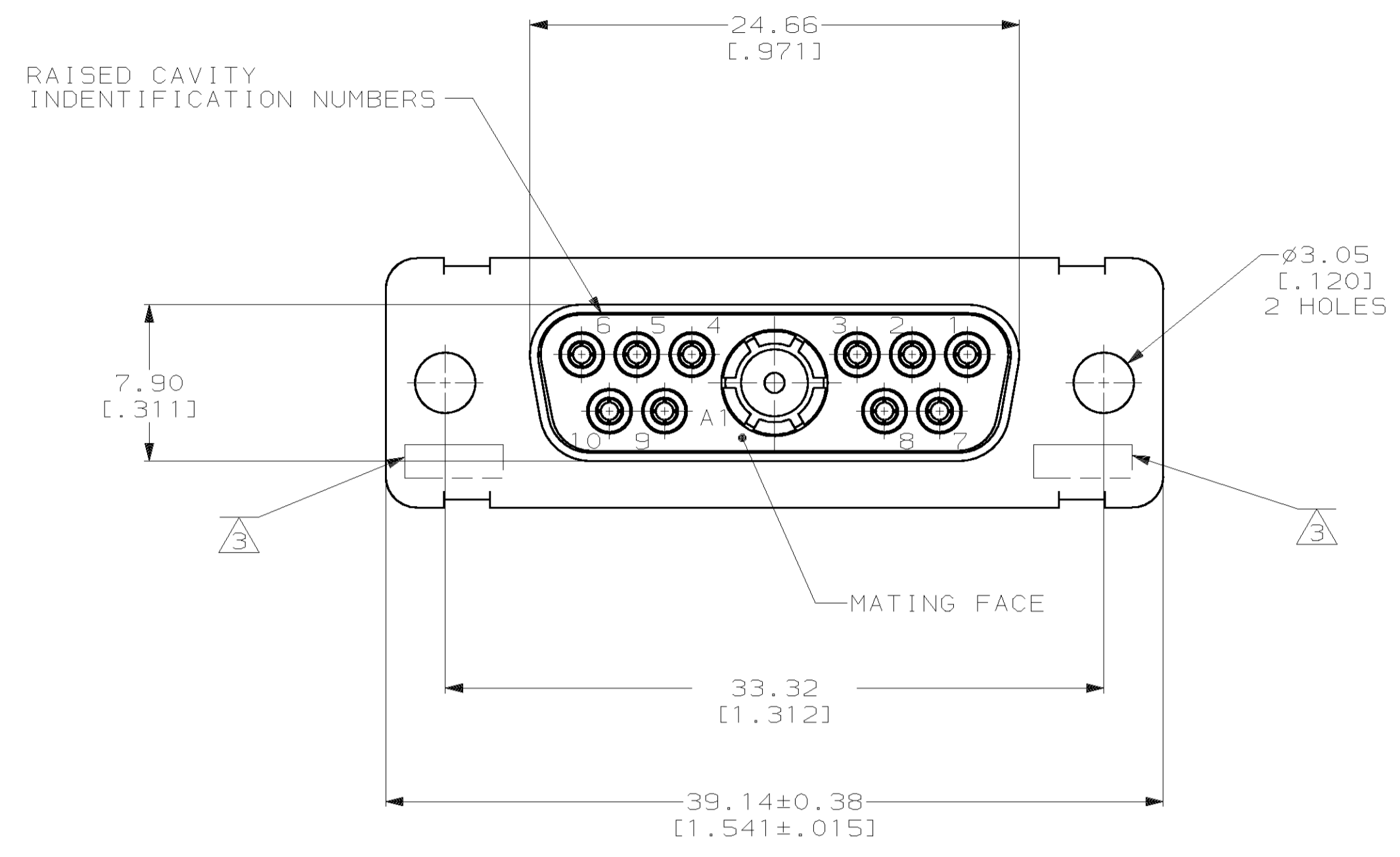

1. THE CONNECTORS DESCRIBED IN THIS DOCUMENT SHALL BE CAPABLE OF MEETING THE REQUIREMENTS OF 108-1770-1 AND MATE WITH ANY APPLICABLE PLUG CONNECTOR WITH SAME INSERT ARRANGEMENT.
2. MARKED WITH 1.19[0.047]-1.57[0.062] HIGH CHARACTERS. FAR SIDE REFERS TO THE WIDE SIDE OF THE KEYSTONE. NEAR SIDE REFERS TO THE NARROW SIDE OF THE KEYSTONE. IF THE FRONT SHELL IS TOO SMALL FOR "AMP", AMP PART NUMBER AND DATE CODE, THEN SPLIT AS FOLLOWS:  
 A. AMP PART NUMBER ON REAR SHELL, FAR SIDE.  
 B. "AMP" AND DATE CODE ON FRONT SHELL, FAR SIDE.
3. UL/CSA DESIGNATION STAMPED IN THIS AREA, OPTIONAL. (NOT ATTACHED TO THE CONNECTOR).
4. POINT OF ELECTRICAL ENGAGEMENT AS MEASURED WITH A 0.991 [0.0390]-0.998 [0.0393] DIA SQUARE ENDED TEST PIN.
5. COAX CENTER CONDUCTOR PIN DIAMETER: .040 [1.02].

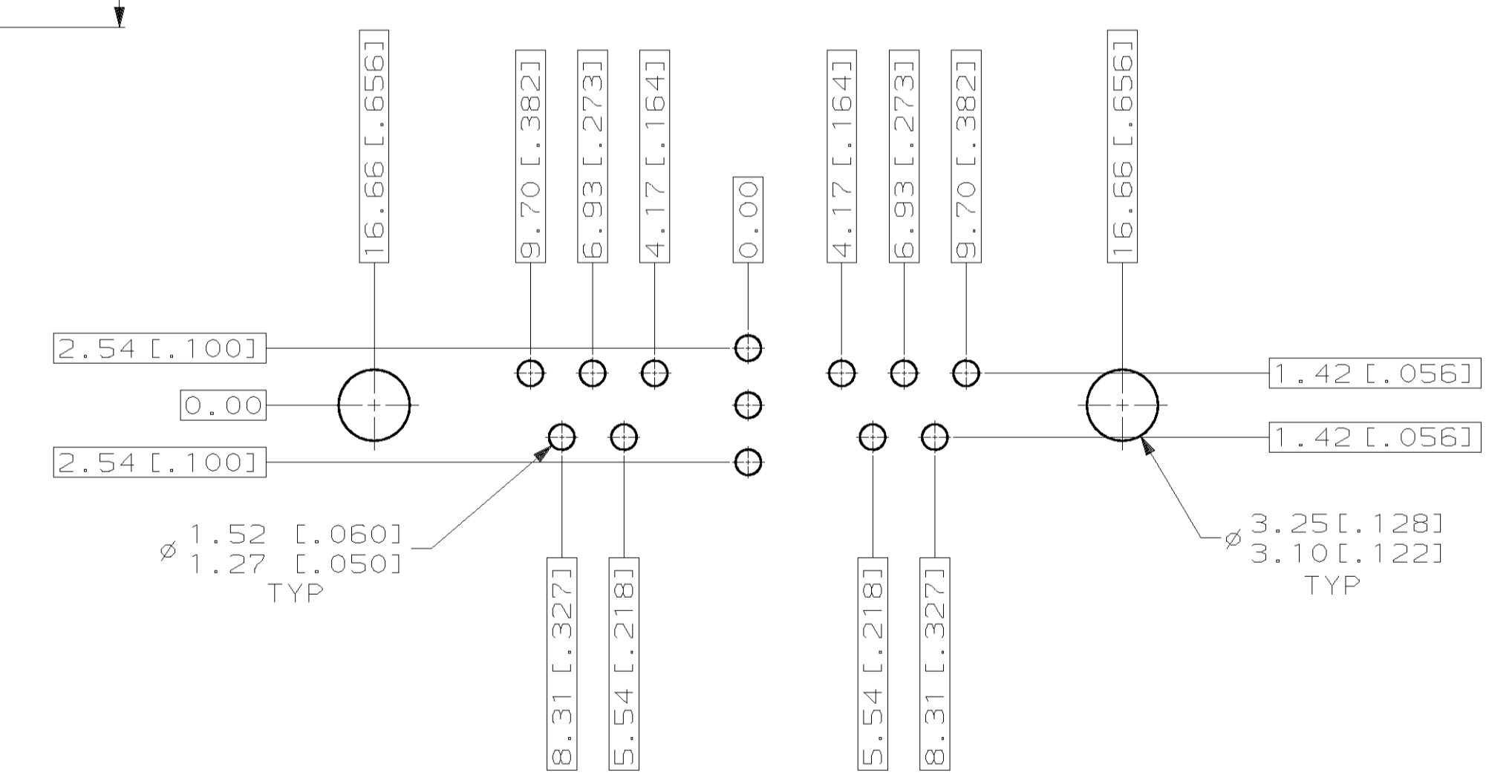
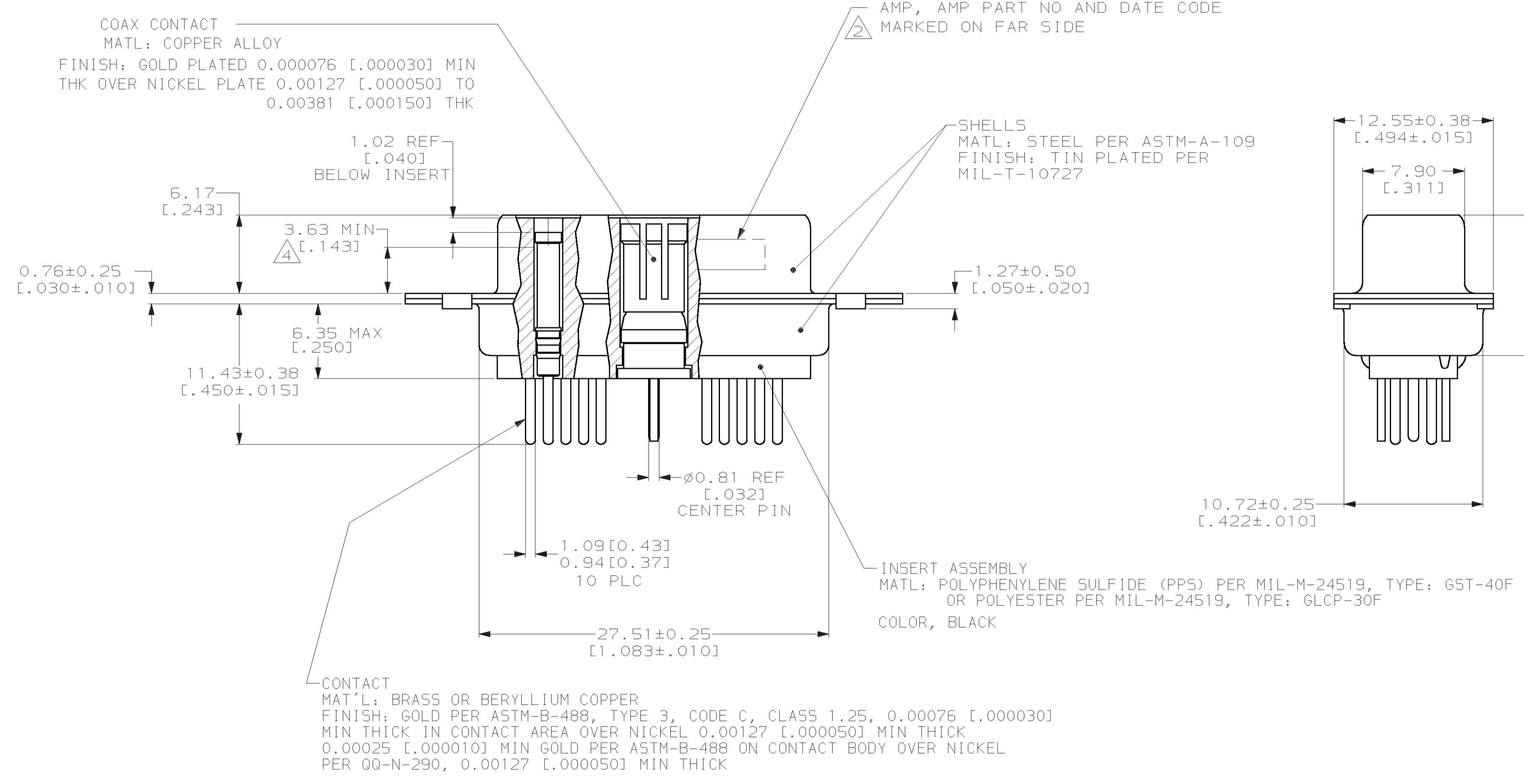

1218764-1  
 PART NUMBER

THIS DRAWING IS A CONTROLLED DOCUMENT.		DWN C.C. THOMAS 6-28-00	AMP Incorporated Harrisburg, PA 17105-3608
DIMENSIONS: mm (INCHES)		CHK D. MILLER 9-19-00	
TOLERANCES UNLESS OTHERWISE SPECIFIED:		APP'D D. MILLER 9-17-00	NAME ASSY, AMPLIMITE, RECEPTACLE, 11C1 LOW PROFILE, SIZE 2, SERIES 109 WITH SPECIAL TAIL LENGTH
MATERIAL SEE CALLOUTS		PRODUCT SPEC APPLICATION SPEC	SIZE A1
FINISH SEE CALLOUTS		WEIGHT -	CAGE CODE 00779
		CUSTOMER DRAWING	DRAWING NO 1218764
		SCALE 4:1	SHEET 1 OF 1
		REV D	