

- NOTES:
- MATERIAL:  
 HOUSING : THERMOPLASTIC, UL94V-0, BLACK COLOR  
 CONTACTS : BRASS  
 GROUNDING SCREW : BRASS  
 SHELL : STEEL
  - FINISH :  
 CONTACT : GOLD FLASH ON CONTACT AREA  
 100μ" MIN. TIN PLATING ON SOLDER TAILS  
 40μ" MIN. NICKEL UNDERPLATING OVERALL  
 SHELL : 40μ" MIN. NICKEL PLATING  
 GROUNDING SCREW : 60μ" MIN. TIN PLATING  
 40μ" MIN. NICKEL UNDERPLATED OVERALL
  - QUALIFICATION TEST REPORT : 501-57590
  - RECOMMENDED PCB THICKNESS : 1.6mm
  - APPLY TO WAVE SOLDERING PROCESS

W/O	1734708-2
W/	1734708-1
SCREW	PART NUMBER

DIMENSION : 0 PLC ±0.5 1 PLC ±0.3 2 PLC ±0.2 3 PLC ± ANGLES ±3'	DWN J. LEE 01-DEC-04	<b>tyco</b> TYCO HOLDINGS (BERMUDA) <b>Electronics</b> VII LTD. TAIWAN BRANCH NAME HD-22, D-Sub, RCPT, V/T, 15PIN
	CHK S. HOU 01-DEC-04	
MATERIAL SEE NOTE	APVD W.J. KE 01-DEC-04	PRODUCT SPEC 108-57517
FINISH SEE NOTE	APPLICATION SPEC 501-57590	LOC DW A <sub>3</sub> DRAWING NO C-1734708 REV O
	WEIGHT	SCALE -- SHEET 1 OF 2

0	NEW RELEASED	FZ00-0266-04	JL SH 01DEC 2004
LTR	REVISION RECORD	ECN	DWN CHK DATE

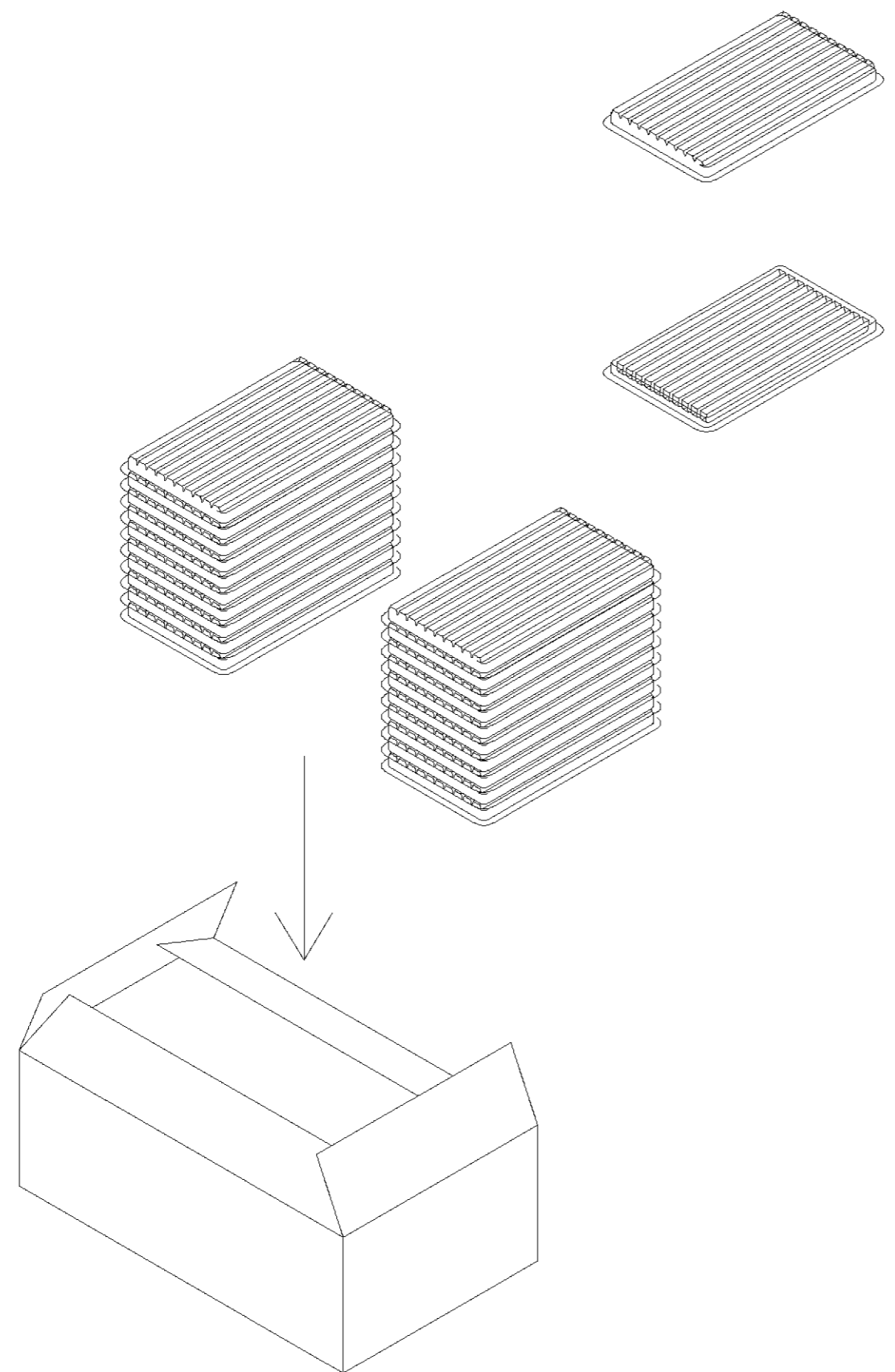

TOP COVER

TRAY

- NOTES :
- DIMENSION :  
 TRAY : L=310, W=230, H=22  
 SHIPPING BOX : L=470, W=320, H=230
  - QUANTITY :  
 90 PCS/TRAY  
 18 TRAYS/SHIPPING BOX (=1620 PCS)
  - WEIGHT :  
 N.W. : 15.5 KG/ SHIPPING BOX  
 G.W. : 17.5 KG/ SHIPPING BOX

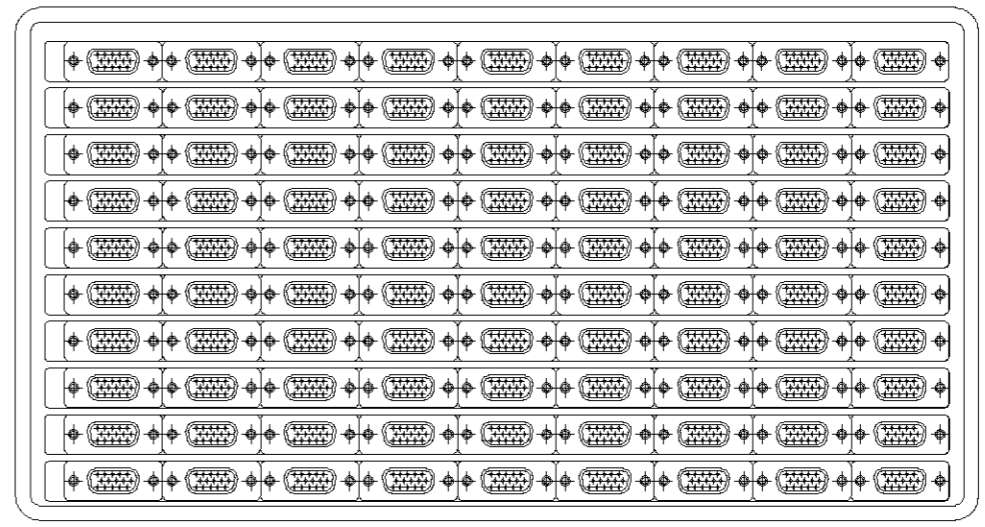

TRAY LAYOUT

DIMENSION :		DWN	J. LEE	<b>tyco</b> TYCO HOLDINGS (BERMUDA) VII LTD. TAIWAN BRANCH
0 PLC ±			01-DEC-04	
1 PLC ±		CHK	S. HOU	NAME
2 PLC ±			01-DEC-04	
3 PLC ±		MATERIAL	APVD	HD-22, D-Sub, RCPT, V/T, 15PIN
ANGLES ±3'			W.J. KE	
SEE NOTE		FINISH	01-DEC-04	LOC SIZE DRAWING NO REV DW A <sub>3</sub> C-1734708 0
SEE NOTE				
		PRODUCT SPEC		SCALE SHEET -- 2 OF 2
		APPLICATION SPEC		
		WEIGHT		

SEE SHEET 1	ECN	DWN	CHK	DATE
LTR	REVISION RECORD			