

NUMBER  
C-1734024

3RD ANGLE PROJECTION

METRIC

THIS INFORMATION IS CONFIDENTIAL AND IS DISCLOSED TO YOU ON CONDITION THAT NO FURTHER DISCLOSURE IS MADE BY YOU TO OTHER THAN AMP PERSONNEL WITHOUT WRITTEN AUTHORIZATION FROM AMP (TAIWAN) LTD. DIMENSIONS IN MILLIMETERS. DO NOT SCALE PRINT.

PRINT  
DW

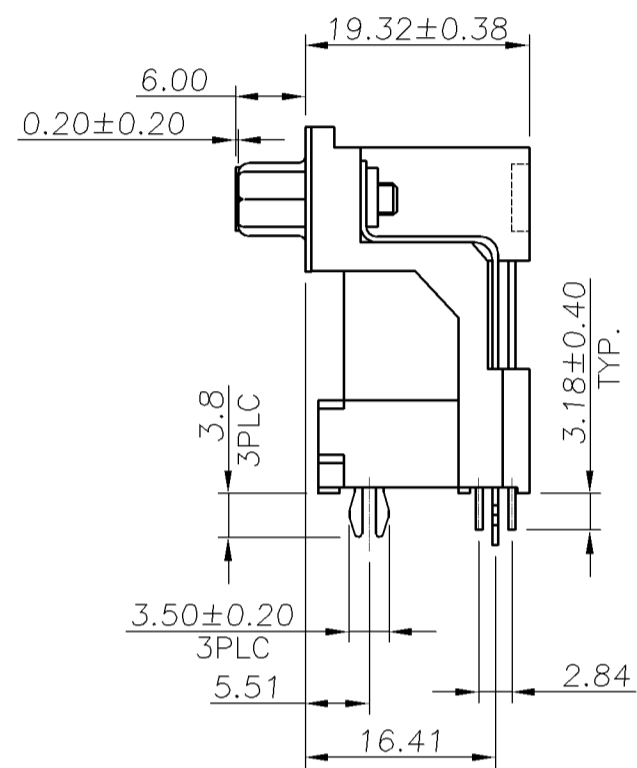
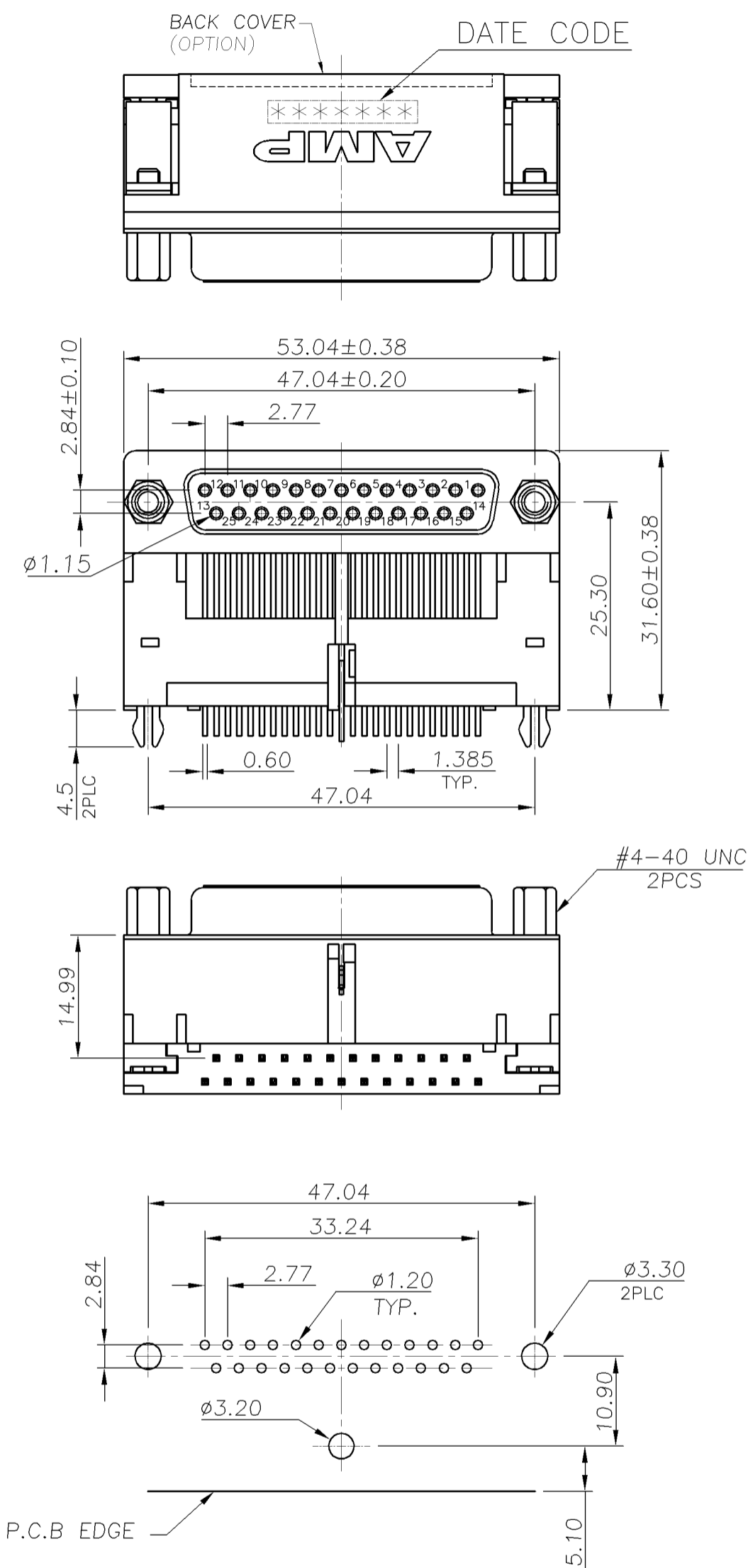

NOTES:

1. MATERIAL:

- 1.1 HOUSING/COVER: THERMOPLASTIC, UL94V-0; COLOR: SEE TABLE
- 1.2 CONTACTS: COPPER ALLY (SEE TABLE)
- 1.3 SHIELD: SPCC
- 1.4 BOARDLOCK: BRASS
- 1.5 SCREW: BRASS
- 1.6 RIVET: BRASS

2. FINISH:

2.1 CONTACT:

- GOLD PLATING (SEE TABLE) ON CONTACT AREA.
- 100µ" MIN. MATTE TIN PLATING ON SOLDER TAIL AREA.
- 50µ" MIN. NICKEL UNDERPLATING OVERALL.

2.2 BOARDLOCK:

- 100µ" MIN. BRIGHT TIN PLATING.
- 50µ" MIN. NICKEL UNDERPLATING OVERALL.
- 2.3 SHIELD: 50µ" MIN. NICKEL PLATED

2.4 RIVET/SCREW: 50µ" MIN. NICKEL PLATED

- 3. RECOMMENDED PCB THICKNESS: 1.2~1.8mm
- 4. WAVE SOLDER CAPABLE TO 265°C PER TYCO SPEC. 109-202, CONDITION B.

27.2	10µ"	W/O	W/	PHOSPHOR BRONZE	BURGUNDY/235C	2-1734024-3
27.2	20µ"	W/	W/	BRASS	BURGUNDY/235C	7-1734024-2
27.2	10µ"	W/	W/	BRASS	BLACK	6-1734024-5
26.24	10µ"	W/	W/O	BRASS	BLACK	6-1734024-4
27.2	10µ"	W/	W/	BRASS	BURGUNDY/235C	6-1734024-2
26.24	10µ"	W/	W/O	BRASS	BURGUNDY/235C	6-1734024-1
NET WEIGHT(g)	GOLD PLATING	BACK COVER	SCREW	CONTACT MATERIAL	HSG/COVER COLOR	PART NUMBER

TOLERANCES UNLESS OTHERWISE SPECIFIED:		DWN		S. HOU		tyco		TYCO HOLDINGS (BERMUDA)	
0 PLC ±0.40		06-DEC-2006		06-DEC-2006		Electronics		VII LTD. TAIWAN BRANCH	
1 PLC ±0.25		CHK		W.J. KE		NAME			
2 PLC ±0.10				06-DEC-2006		RECEPTACLE ASSEMBLY,			
3 PLC ±0.10						HIGH-RISE, 25 POSITION,			
ANGLES ±3°						AMPLIMITE			
MATERIAL		APVD		W.J. KE		PRODUCT SPEC			
SEE NOTE				06-DEC-2006		108-57388			
FINISH		QUALIFICATION TEST REPORT		LOC		SIZE		DRAWING NO	
SEE NOTE		501-57420		DW		A <sub>3</sub>		C-1734024	
WEIGHT		SEE TABLE		SCALE		SHEET		REV	
				--		1 OF 2		C	

C	REVISED	ECR-06-028090	SH	06DEC
			WK	2006
B	REVISED	ECR-05-0145959	SH	09NOV
			WK	2005
A	ADDED P/N: 7-2, 2-3	FZ00-0261-04	SH	11NOV
			WK	2004
O	FIRST RELEASED	FZ00-0174-04	SH	29JUL
			WK	2004
LTR	REVISION RECORD	ECN	DWN	DATE
			CHK	

NUMBER C-1734024

3RD ANGLE PROJECTION

METRIC

THIS INFORMATION IS CONFIDENTIAL AND IS DISCLOSED TO YOU ON CONDITION THAT NO FURTHER DISCLOSURE IS MADE BY YOU TO OTHER THAN AMP PERSONNEL WITHOUT WRITTEN AUTHORIZATION FROM AMP (TAIWAN) LTD. DIMENSIONS IN MILLIMETERS. DO NOT SCALE PRINT.

PRINT DW

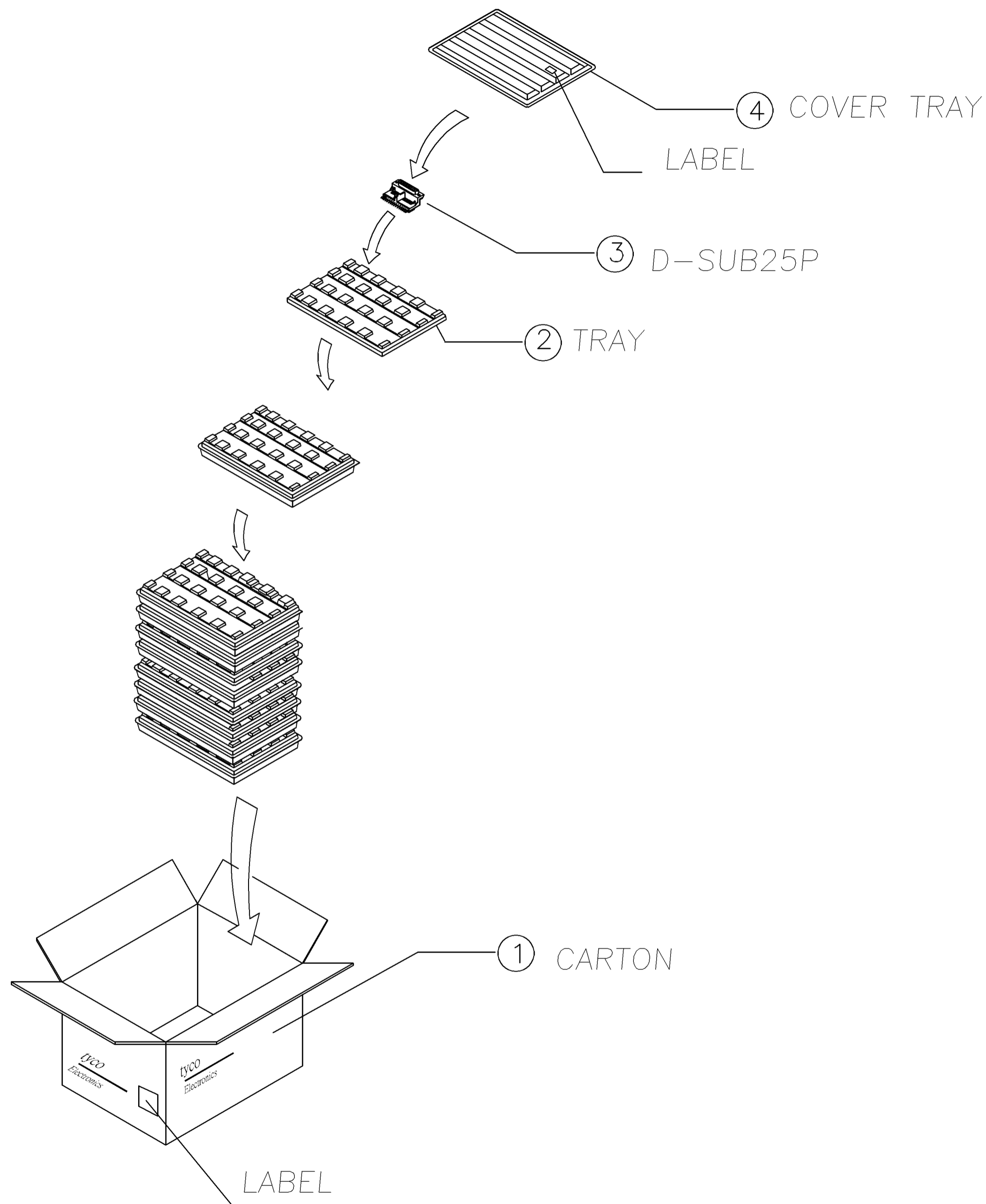

NOTES :

1. MATERIAL :
  - 1.1 TRAY : PVC
  - 1.2 SHIPPING CARTON : CORRUGATED FIBERBOARD
2. DIMENSION :
  - 2.1 TRAY : L=312, W=218, H=27.5
  - 2.1 SHIPPING CARTON : L=325, W=230, H=295
3. QUANTITY :
  - 3.1 PRIMARY PACKING: 20 PCS/TRAY
  - 3.2 SECONDARY PACKING: 10TRAYS/CARTON(200PCS)
4. WEIGHT : SEE TABLE

7.358	5.248	W/O
7.55	5.44	W/
NET WEIGHT(Kg)	NET WEIGHT(Kg)	SCREW

TOLERANCES UNLESS OTHERWISE SPECIFIED: 0 PLC ± 1 PLC ± 2 PLC ± 3 PLC ± ANGLES ±		DWN S. HOU 06-DEC-2006	<b>tyco</b> <b>Electronics</b> TYCO HOLDINGS (BERMUDA) VII LTD. TAIWAN BRANCH	
MATERIAL  SEE NOTE		CHK W.J. KE 06-DEC-2006	NAME  RECEPTACLE ASSEMBLY, HIGH-RISE, 25 POSITION, AMPLIMITE	
FINISH  SEE NOTE		APVD W.J. KE 06-DEC-2006	LOC DW	SIZE A <sub>3</sub>
		PRODUCT SPEC -	DRAWING NO C-1734024	REV C
		QUALIFICATION TEST REPORT -	SCALE --	SHEET 2 OF 2
		WEIGHT		

SEE SHEET 1	ECN	DWN	CHK	DATE
LTR	REVISION RECORD			

8 7 6 5 4 3 2 1 CUSTOMER DRAWING