

THIS DRAWING IS UNPUBLISHED. RELEASED FOR PUBLICATION  
 © COPYRIGHT 2005 BY TYCO ELECTRONICS CORPORATION. ALL RIGHTS RESERVED.

LOC		DIST		REVISIONS			
P	LTR	DESCRIPTION	DATE	DWN	APVD		
GP	00	Z	REVISED PER ECO-06-024575	24JAN07	JDP	EDB	

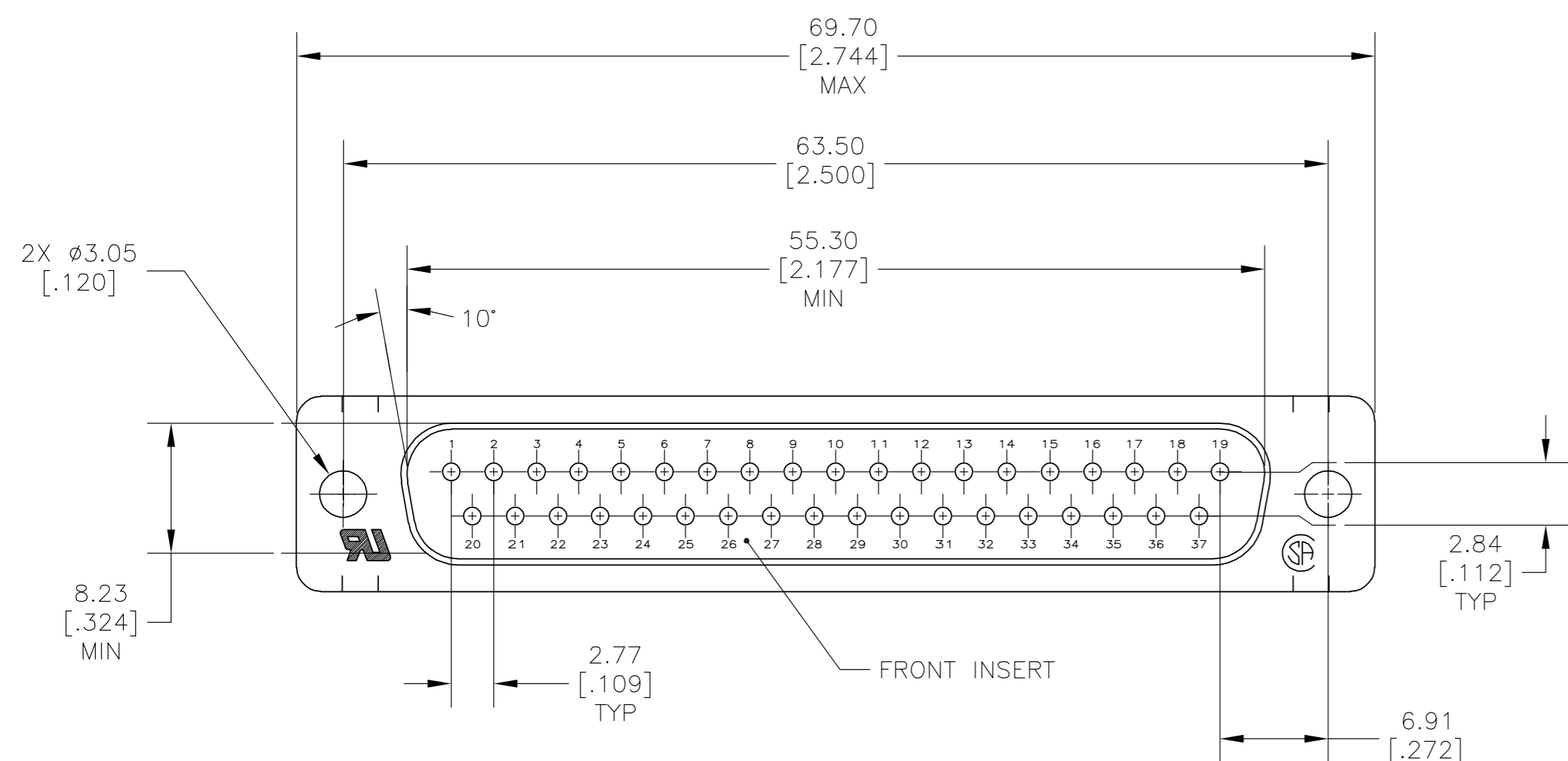

- 1. MOLDED PARTS: GLASS FILLED NYLON, SE-1 GRADE, BLACK.  
SHELLS: CARBON STEEL PER QQ-S-698.  
CONTACTS: BRASS PER MIL-C-50.
- 2. SHELLS: 5.08µm [.000200] MIN ZINC WITH YELLOW CHROMATE COATING.  
CONTACTS: GOLD PLATED FOR LENGTH OF 3.81 [.150] MIN FROM MATING END,  
0.76µm [.000030] MIN GOLD IN MATED AREA,  
2.54µm [.000100] MIN TIN-LEAD ON SOLDER END, BOTH OVER  
1.27µm [.000050] MIN NICKEL.  
OR  
GOLD FLASH OVER PALLADIUM NICKEL PLATED FOR LENGTH OF  
3.81 [.150] MIN FROM MATING END,  
0.76µm [.000030] MIN PALLADIUM NICKEL IN MATED AREA,  
2.54µm [.000100] MIN TIN-LEAD ON SOLDER END, BOTH OVER  
1.27µm [.000050] MIN NICKEL.
- 3. THIS PLUG ACCEPTS SIZE 20 PIN CONTACTS PER AMP DWG 66481.
- 4. RETENTION TINES ARE AN INTEGRAL PART OF INSERT.
- 5. FOR MATING PART SEE DWG 205713.
- 6. POST TIPS FALL WITHIN .020 DIA TRUE POSITION OF EACH OTHER.
- 7. GOLD PLATED FOR LENGTH OF 3.81 [.150] MIN FROM MATING END,  
GOLD FLASH IN MATED AREA. 2.54µm [.000100] MIN  
TIN-LEAD ON SOLDER END, ALL OVER 1.27µm [.000050] MIN NICKEL.

AMP, PART NO & DATE CODE  
 MARKED IN AREA INDICATED,  
 ON FAR SIDE

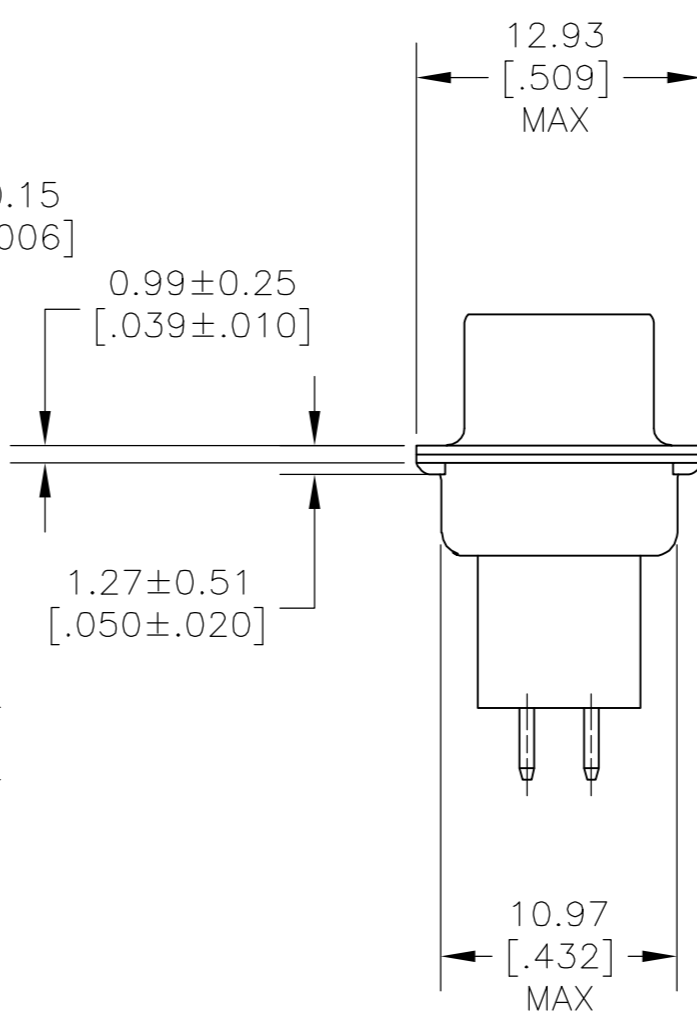
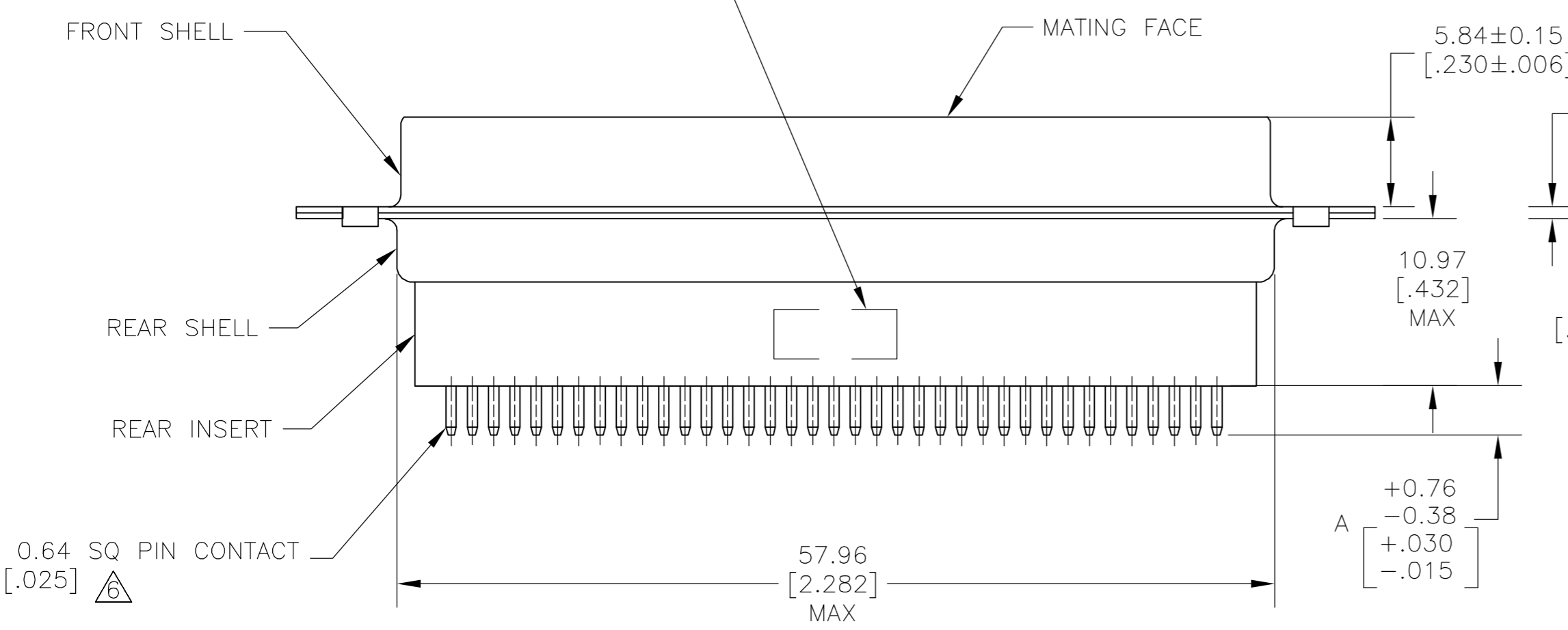

SUPSD BY 205714-7	-	-	205714-8
	2	4.78 [.188]	205714-7
OBSOLETE	7	16.54 [.651]	205714-6
OBSOLETE	-	-	205714-5
SUPSD BY 205714-7	7	10.85 [.427]	205714-4
SUPSD BY 205714-7	2	10.85 [.427]	205714-3
SUPSD BY 205714-7	7	3.18 [.125]	205714-2
SUPSD BY 205714-7	2	3.18 [.125]	205714-1
	CONTACT FINISH	A	PART NUMBER

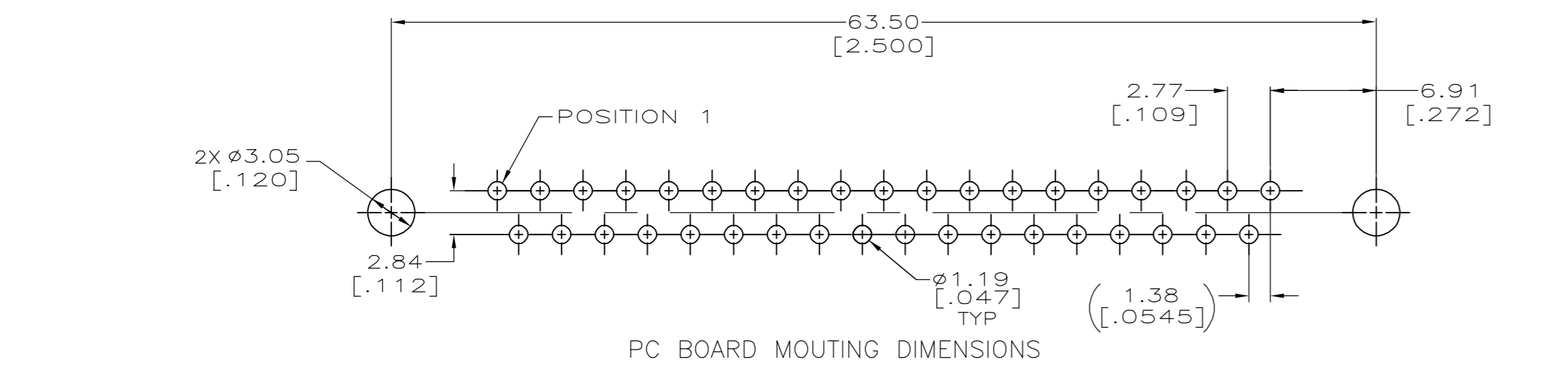

THIS DRAWING IS A CONTROLLED DOCUMENT.

DIMENSIONS: mm [INCHES]	TOLERANCES UNLESS OTHERWISE SPECIFIED:	DWN J. POLIGNONE 01FEB07	Tyco Electronics Corporation Harrisburg, Pa 17105-3608
		CHK E. BRIANT 01FEB07	
		APVD E. BRIANT 01FEB07	
		NAME E. BRIANT	
		PRODUCT SPEC 108-40025	PLUG ASSY, SIZE 4, 37 POS, VERTICAL, AMPLIMITE HDP
MATERIAL	FINISH	WEIGHT -	SIZE A2 CAGE CODE 00779 C=205714
		CUSTOMER DRAWING	RESTRICTED TO -

SCALE 3:1 SHEET 1 OF 1 REV Z