

THIS DRAWING IS UNPUBLISHED. RELEASED FOR PUBLICATION
 © COPYRIGHT BY TYCO ELECTRONICS CORPORATION. ALL RIGHTS RESERVED.

LOC	DIST	REVISIONS					
GP	00	P	LTR	DESCRIPTION	DATE	DWN	APVD
		Y		REVISED PER ECO-06-024575	25JAN07	JDP	EDB

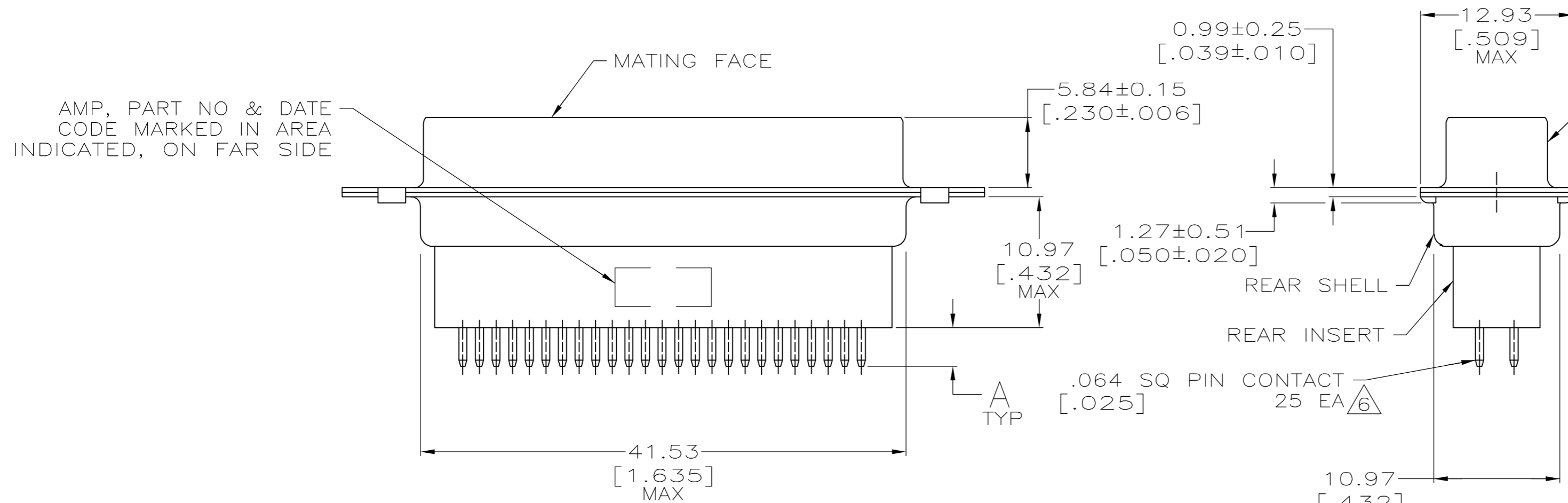
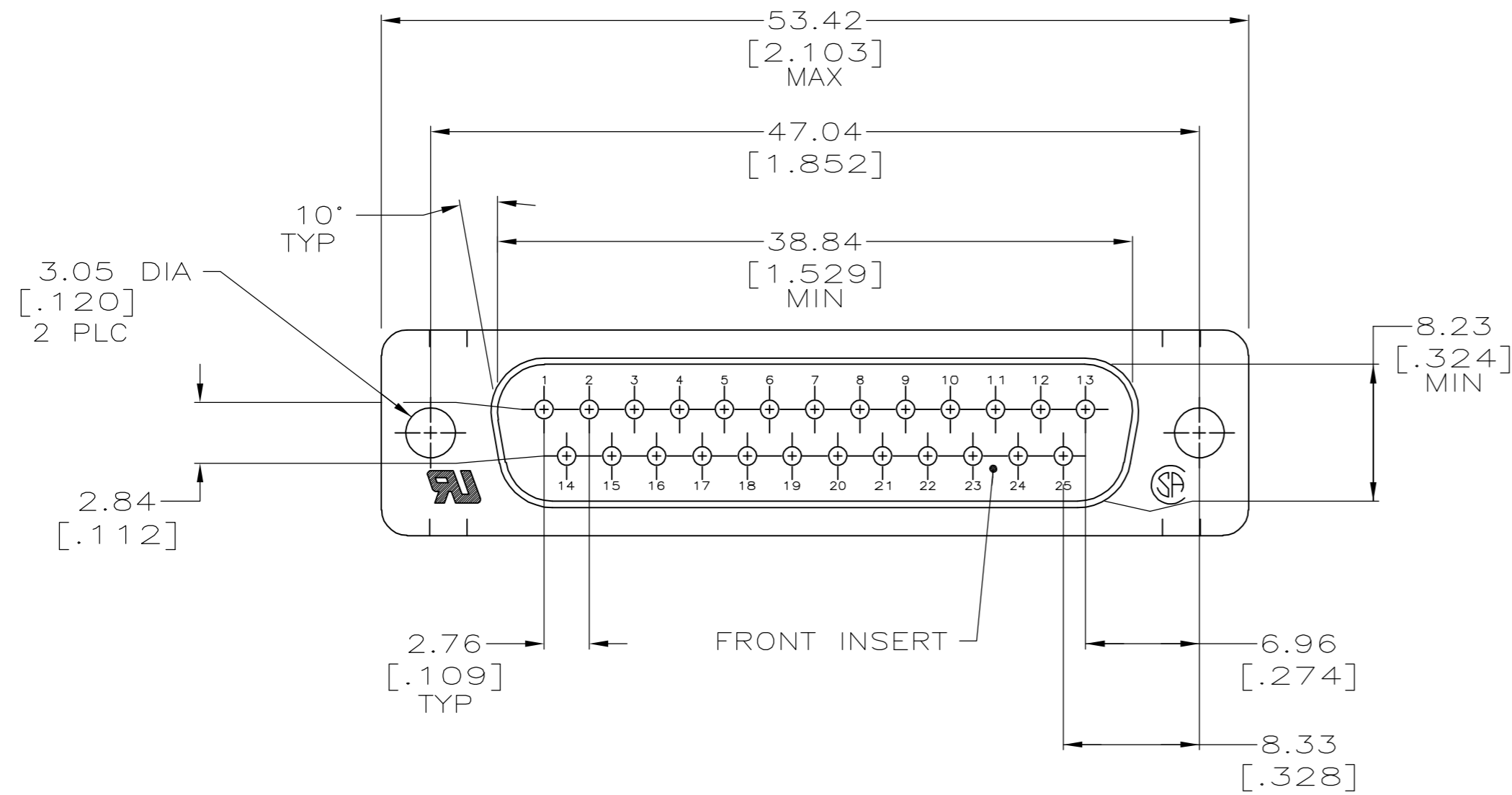

- ⚠ MOLDED PARTS: GLASS FILLED NYLON, BLACK, SE-0 GRADE.
SHELLS: CARBON STEEL PER QQ-S-698
CONTACTS: BRASS PER MIL-C-50.
- ⚠ ZINC PLATING PER ASTM B633; TYPE II; CLASS SC1; YELLOW CHROMATE,
GOLD PLATING PER MIL-G-45204, NICKEL PLATING PER QQ-N-290.
SHELLS: ZINC PLATED.
CONTACTS: GOLD PLATED FOR LENGTH OF 3.81 [.150] MIN FROM MATING END,
MIN GOLD (SEE TABLE) IN MATED AREA. 2.54μm [.000100] MIN TIN-LEAD
ON SOLDER END, ALL OVER 1.27μm [.000050] MIN NICKEL.
- 3. THIS PLUG ACCEPTS SIZE 20 PIN CONTACT PER AMP DWG 66481.
- 4. RETENTION TINES ARE AN INTEGRAL PART OF INSERT.
- 5. FOR MATING PART SEE DWG 205738.
- ⚠ POST TIPS FALL WITHIN .020 DIA TRUE POSITION OF EACH OTHER.
- ⚠ OBSOLETE PART NUMBER.
- ⚠ SHELLS: 5.08μm [.000200] MIN ZINC WITH YELLOW CHROMATE COATING.
CONTACTS: GOLD PLATED FOR LENGTH OF 3.81 [.150] MIN FROM MATING END,
0.76μm [.000030] MIN GOLD IN MATED AREA,
2.54μm [.000100] MIN TIN-LEAD ON SOLDER END, BOTH OVER
1.27μm [.000050] MIN NICKEL.
OR
GOLD FLASH OVER PALLADIUM NICKEL PLATED FOR LENGTH OF
3.81 [.150] MIN FROM MATING END,
0.76μm [.000030] MIN PALLADIUM NICKEL IN MATED AREA,
2.54μm [.000100] MIN TIN-LEAD ON SOLDER END, BOTH OVER
1.27μm [.000050] MIN NICKEL.

	-	-	⚠	205737-9
SUPSD 205737-7	⚠	4.78 [.188]		205737-8
	⚠	4.78 [.188]		205737-7
SUPSD 205737-7	⚠	16.54 [.651]		205737-6
	-	-	⚠	205737-5
SUPSD 205737-7	⚠	10.85 [.427]		205737-4
SUPSD 205737-7	⚠	10.85 [.427]		205737-3
SUPSD 205737-7	⚠	3.18 [.125]		205737-2
SUPSD 205737-7	⚠	3.18 [.125]		205737-1
	GOLD FINISH	A		PART NUMBER

THIS DRAWING IS A CONTROLLED DOCUMENT.

DIMENSIONS: mm [INCHES]	TOLERANCES UNLESS OTHERWISE SPECIFIED:	DWN J. POLIGNONE 01FEB07	Tyco Electronics Corporation Harrisburg, PA 17105-3608
	0 PLC ± -	CHK E. BRIANT 01FEB07	
	1 PLC ± -	APVD E. BRIANT 01FEB07	
	2 PLC ± 0.13 [.005]	PRODUCT SPEC	
MATERIAL	FINISH	APPLICATION SPEC	NAME PLUG ASSY, SIZE 3, 25 POS, VERTICAL, -
		WEIGHT	SIZE A2
		CUSTOMER DRAWING	CAGE CODE 00779
			DRAWING NO C=205737
			RESTRICTED TO
			SCALE 3:1
			SHEET 1 of 1
			REV Y