

| LOC |    | DIST |                       | REVISIONS |    |      |  |
|-----|----|------|-----------------------|-----------|----|------|--|
| DF  | DO | REV  | DESCRIPTION           | DATE      | BY | APPV |  |
|     |    | K    | REV PER ECO-06-018048 | 05OCT06   | PY | DM   |  |

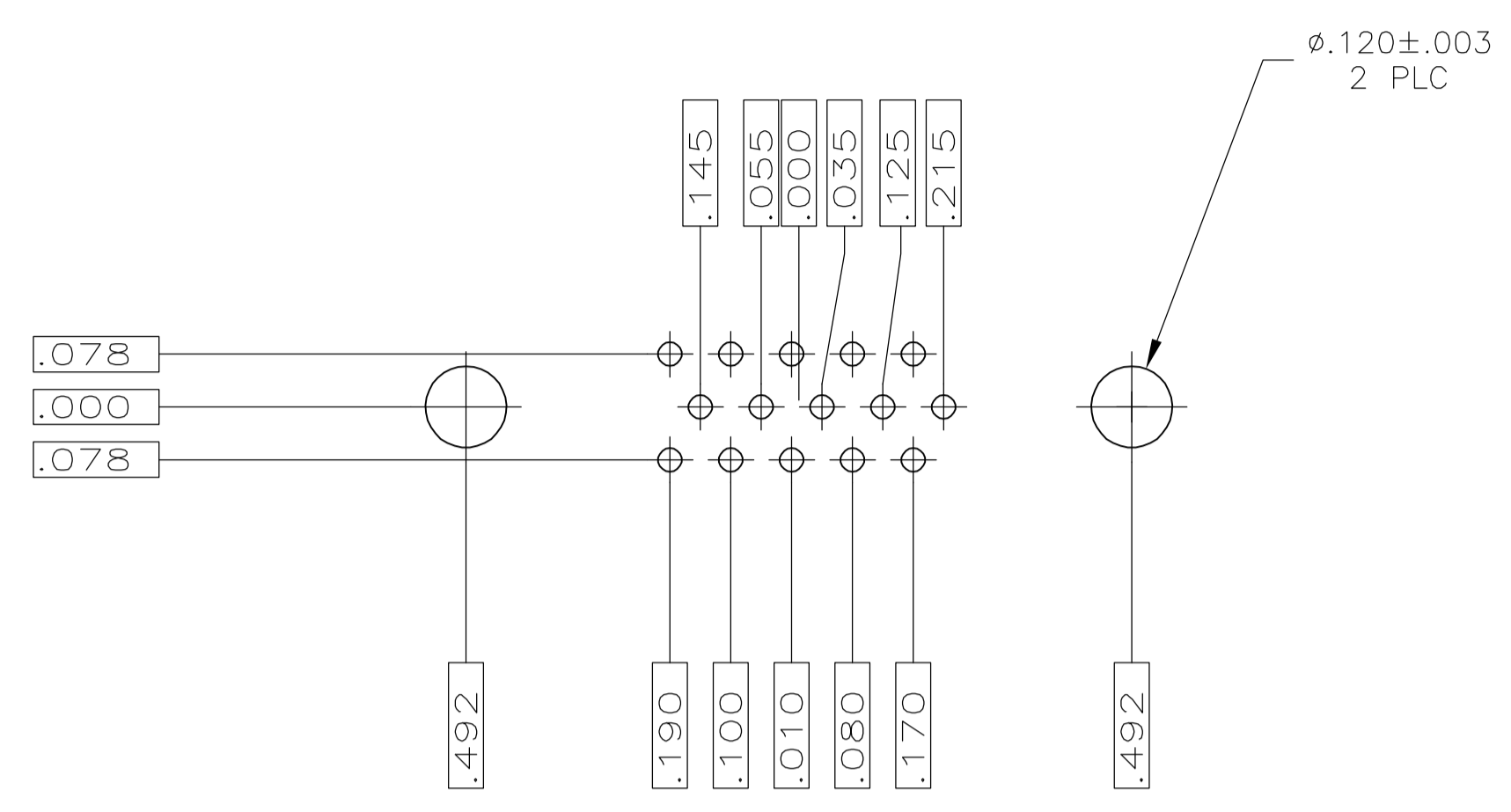

- △ SOCKET CONTACT
- CONTACT BODY MAT'L: LEADED NICKEL COPPER (PROPRIETARY)
- ALTERNATE MAT'L: COPPER ALLOY PER ASTM-B-197
- FINISH: GOLD PER MIL-G-45204 OVER NICKEL PER QQ-N-290
- △ FINISH: CADMIUM PER QQ-P-416
- △ FINISH: TIN PLATED PER MIL-T-10727
- 4. .040 DIA HOLE IS RECOMMENDED FOR P.C. BOARD
- 5. CONNECTOR MATES WITH ANY AMP 15 POSN PLUG
- 6. REPLACEMENT SOCKET AMP# 207684-4
- △ UL/CSA DESIGNATION STAMPED IN THIS AREA.
- △ FINISH: ZINC PLATED PER ASTM-B-633, .000200-.000400 THK WITH SUPPLEMENTARY CHROMATE (Cr3+)

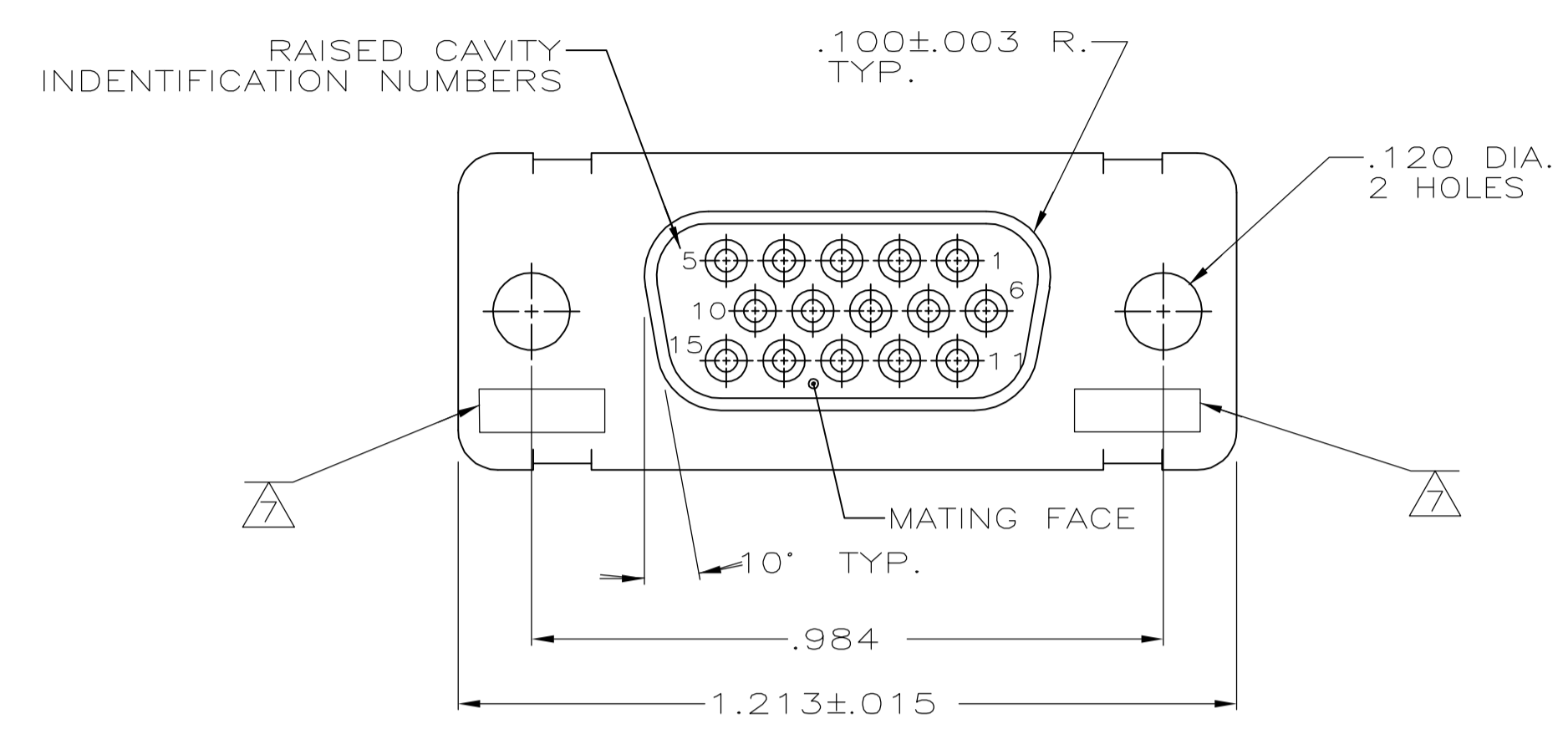
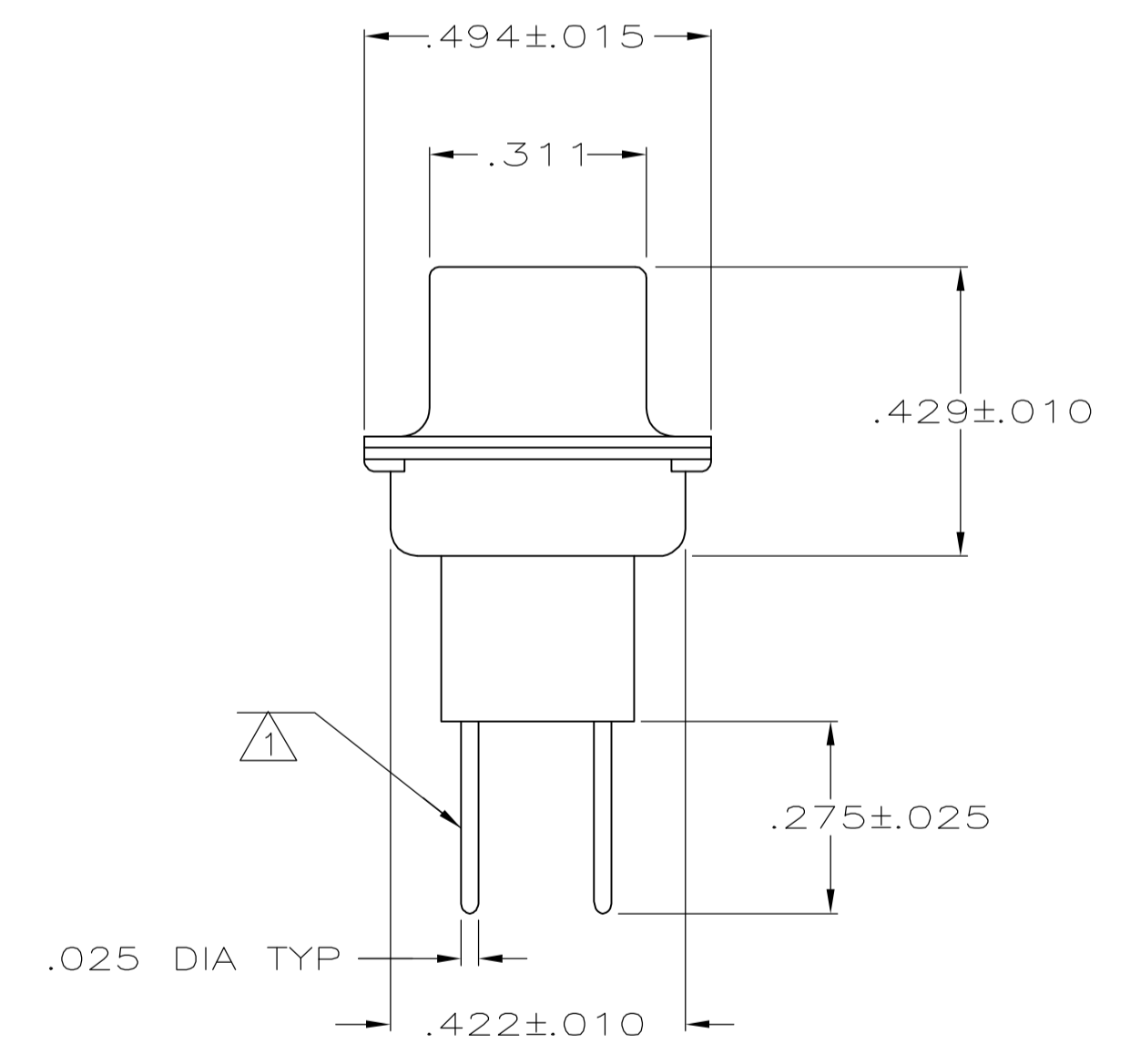
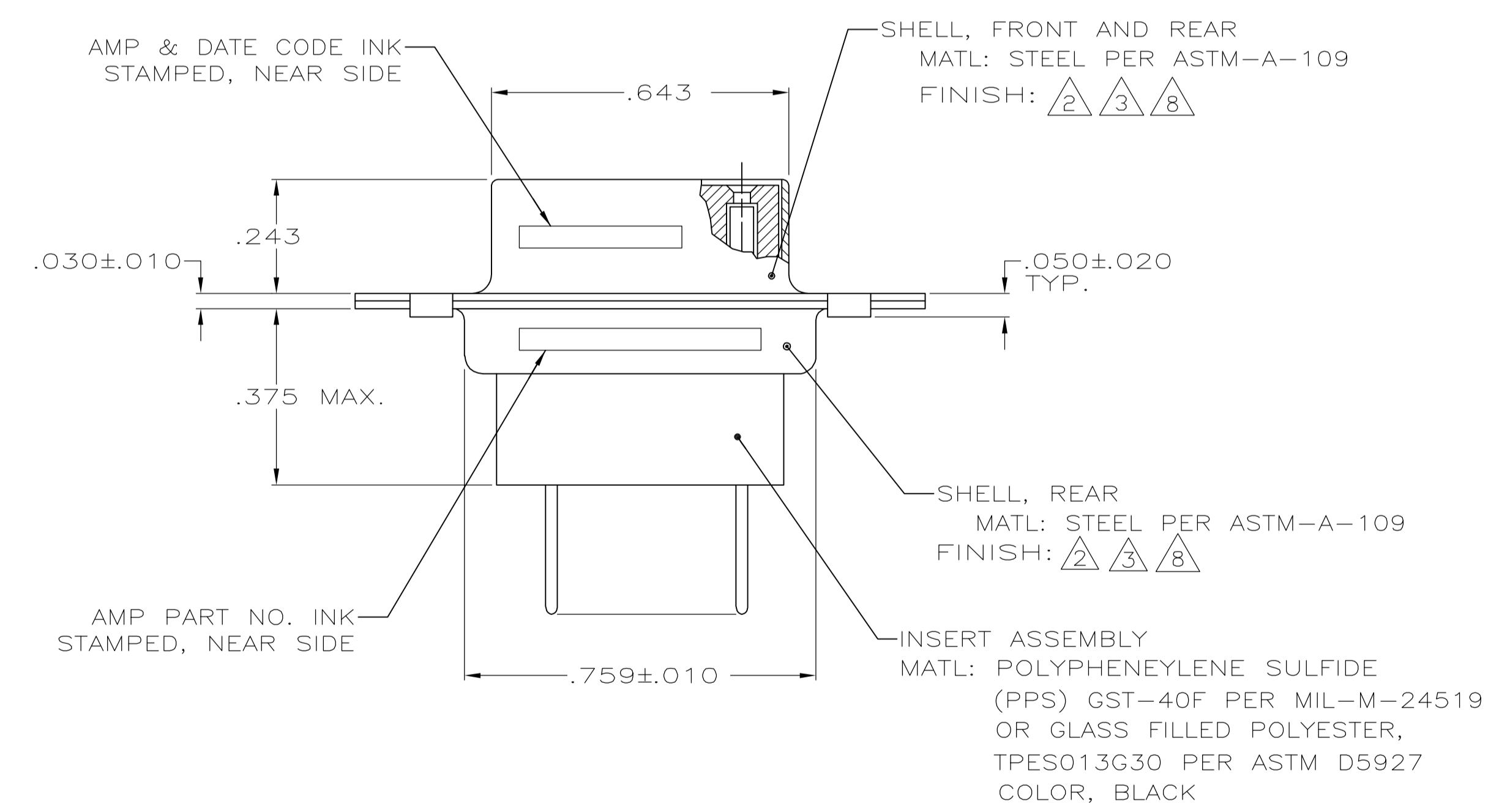

|               |            |
|---------------|------------|
| PLATED PER △8 | 5-208869-1 |
| PLATED PER △3 | 208869-2   |
| PLATED PER △2 | 208869-1   |
| DESCRIPTION   | PART NO.   |

THIS DRAWING IS A CONTROLLED DOCUMENT.

|                       |  |                        |                           |                  |                    |                     |   |
|-----------------------|--|------------------------|---------------------------|------------------|--------------------|---------------------|---|
| DIMENSIONS: INCHES    | TOLERANCES UNLESS OTHERWISE SPECIFIED: | DWG: C.C.THOMAS 1-6-88 | CHK: F.BALLEW III 1-25-88 | APVD: -          | NAME: -            | tyco<br>Electronics | Tyco Electronics Corporation<br>Harrisburg, Pa 17105-3608 |
| 0 PLC ± -             | 1 PLC ± -                              | 2 PLC ± -              | 3 PLC ± .005              | 4 PLC ± -        | ANGLES ± -         | PRODUCT SPEC        | APPLICATION SPEC  |
| MATERIAL SEE CALLOUTS | FINISH SEE CALLOUTS                    | WEIGHT                 | SIZE: A1                  | CAGE CODE: 00779 | DRAWING NO: 208872 | RESTRICTED TO       |   |
| CUSTOMER DRAWING      |  | SCALE: 4:1             | SHEET: 1 OF 1             | REV: K           |                    |                     |   |