

- HOUSING MATERIAL: PBT, GLASS FILLED, BLACK, UL 94V-0 RATED.
- CONTACT MATERIAL: PHOSPHOR BRONZE.
- CONTACT FINISH: GOLD PLATE IN MATING AREA (SEE TABLE) 120μ" MIN TIN PLATE ON SOLDER TAIL, BOTH OVER 50μ" NICKEL UNDERPLATE.
- SHELL: STEEL, NICKEL PLATE.
- THREADED INSERT: BRASS, NICKEL PLATE.
- FOUR DIGIT DATE CODE IN THIS FORMAT.  

Q4	45
YEAR	MANUFACTURING WEEK
- DATUMS 

-X-	-Y-
-----	-----

 TO BE ESTABLISHED BY CUSTOMER.

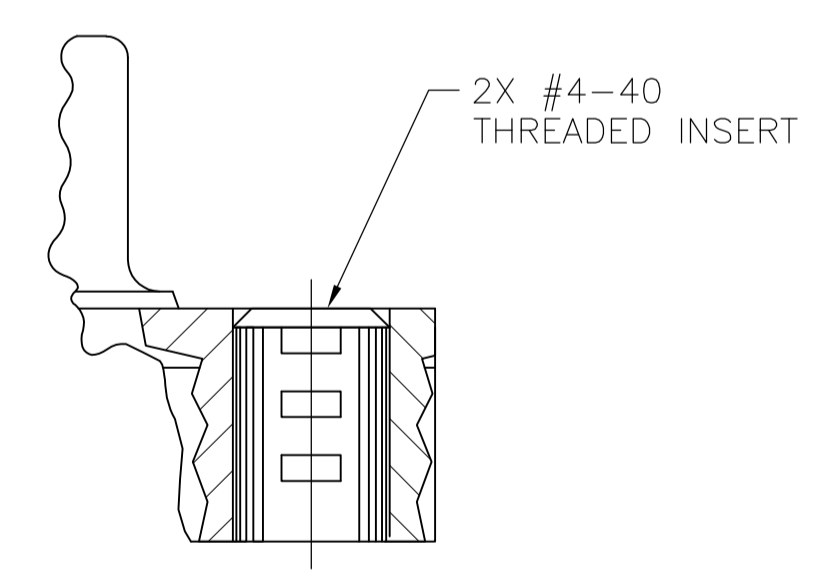
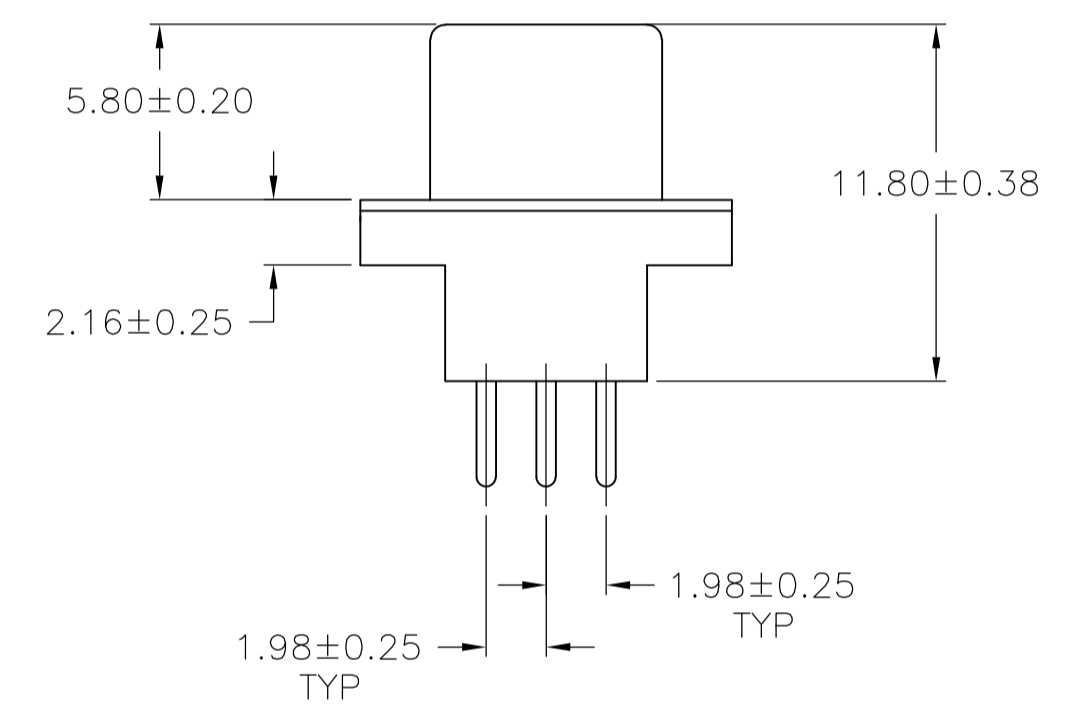
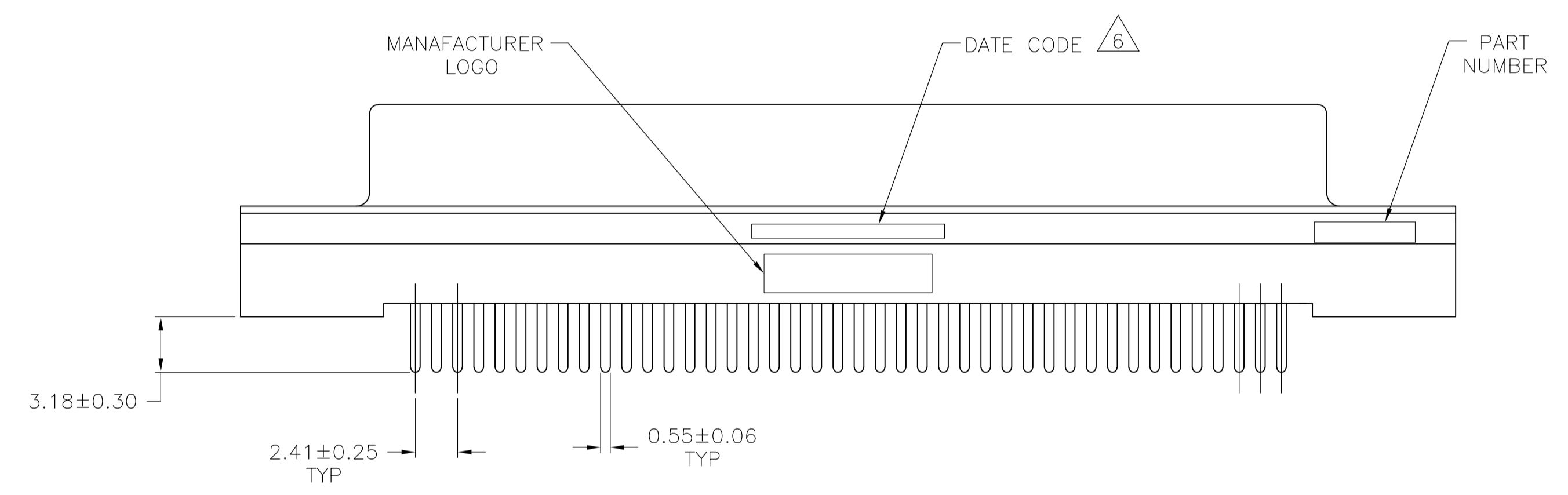

DETAIL B

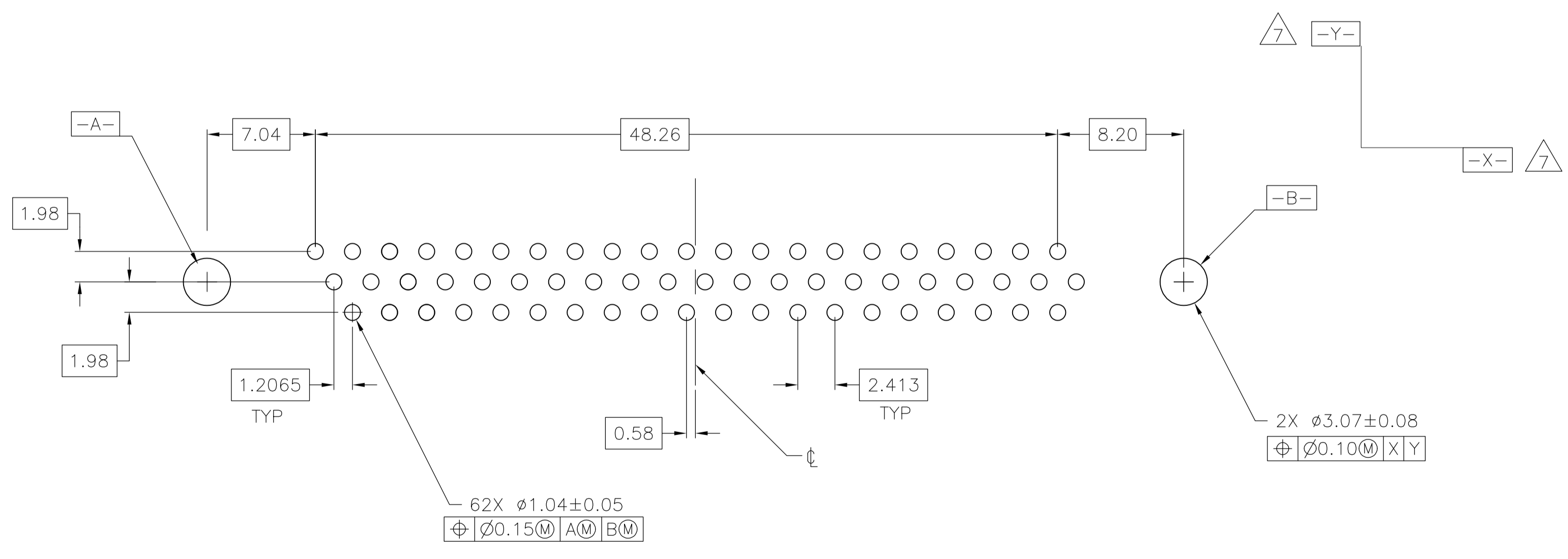

RECOMMENDED PCB LAYOUT

TRAY	DETAIL B	GOLD FLASH	3-5747786-4
TRAY	DETAIL B	30μ" MIN GOLD	5747786-6
PACKAGING	MOUNTING FLANGE CONFIGURATION	CONTACT MATING AREA FINISH	PART NUMBER

THIS DRAWING IS A CONTROLLED DOCUMENT.		DIN 9138 MCMASTER 13SEP05	Tyco Electronics Corporation Harrisburg, PA 17105-3608	
DIMENSIONS: mm		CIK S. BOLASH 13SEP05	NAME M. WALMSLEY 13SEP05	
TOLERANCES UNLESS OTHERWISE SPECIFIED:		PRODUCT SPEC 108-1092		
0. PLC ± -		APPLICATION SPEC 114-13199		
1. PLC ± -		SIZE CAGE CODE DRAWING NO. RESTRICTED TO		
2. PLC ± -		A1 00779 C=5747786		
3. PLC ± -		WEIGHT		
4. PLC ± -		CUSTOMER DRAWING SCALE 4:1 SHEET 1 OF 1 REV A		
ANGLES ± ± -				
MATERIAL FINISH				