

- ① HOUSING: NYLON OR POLYESTER, FLAME RETARDANT, UL 94V-0, GLASS FILLED, BLACK.  
 CONTACTS: BRASS  
 SHELL: CARBON STEEL  
 EYELETS: BRASS  
 SCREWLOCKS & INSERTS: ZINC  
 BOARDLOCKS: COPPER ALLOY
- ② SHELL: 2.54µm[.000100] MIN TIN OVER 1.27µm[.000050] MIN COPPER.  
 EYELETS: 2.54µm[.000100] MIN TIN OVER COPPER FLASH.  
 BOARDLOCKS: 3.81µm[.000150] MIN TIN OVER 1.27µm[.000050] MIN NICKEL.  
 CONTACTS: GOLD PLATED FOR A LENGTH OF 3.81 [.150] MIN FROM MATING END, 0.76µm [.000030] MIN GOLD IN MATED AREA, 2.54µm [.000100] MIN TIN FOR A LENGTH OF 3.56 [.140] MIN FROM OPPOSITE END, BOTH OVER 1.27µm[.000050] MIN NICKEL.  
 -OR-  
 GOLD FLASH OVER PALLADIUM NICKEL PLATED FOR A LENGTH OF 3.81 [.150] MIN FROM MATING END, 0.76µm [.000030] MIN PALLADIUM NICKEL IN MATED AREA, 2.54µm [.000100] MIN TIN FOR A LENGTH OF 3.56 [.140] MIN FROM OPPOSITE END, BOTH OVER 1.27µm[.000050] MIN NICKEL.  
 SCREWLOCKS & INSERTS: CLEAR CHROMATE

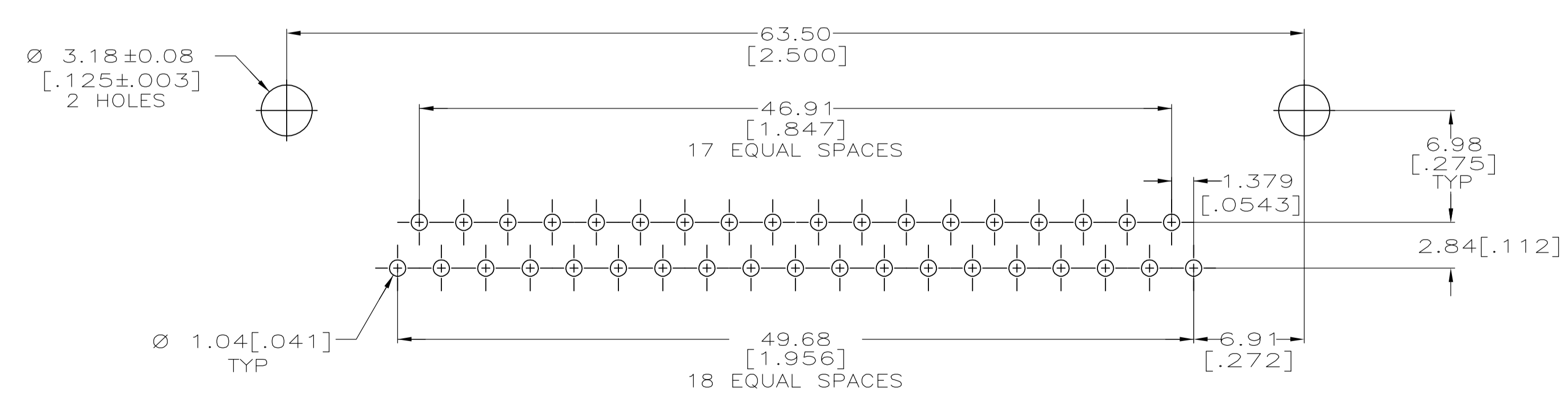

RECOMMENDED P.C. BOARD MOUNTING DIMENSIONS  
 P.C. BOARD THICKNESS: 1.57[.062]

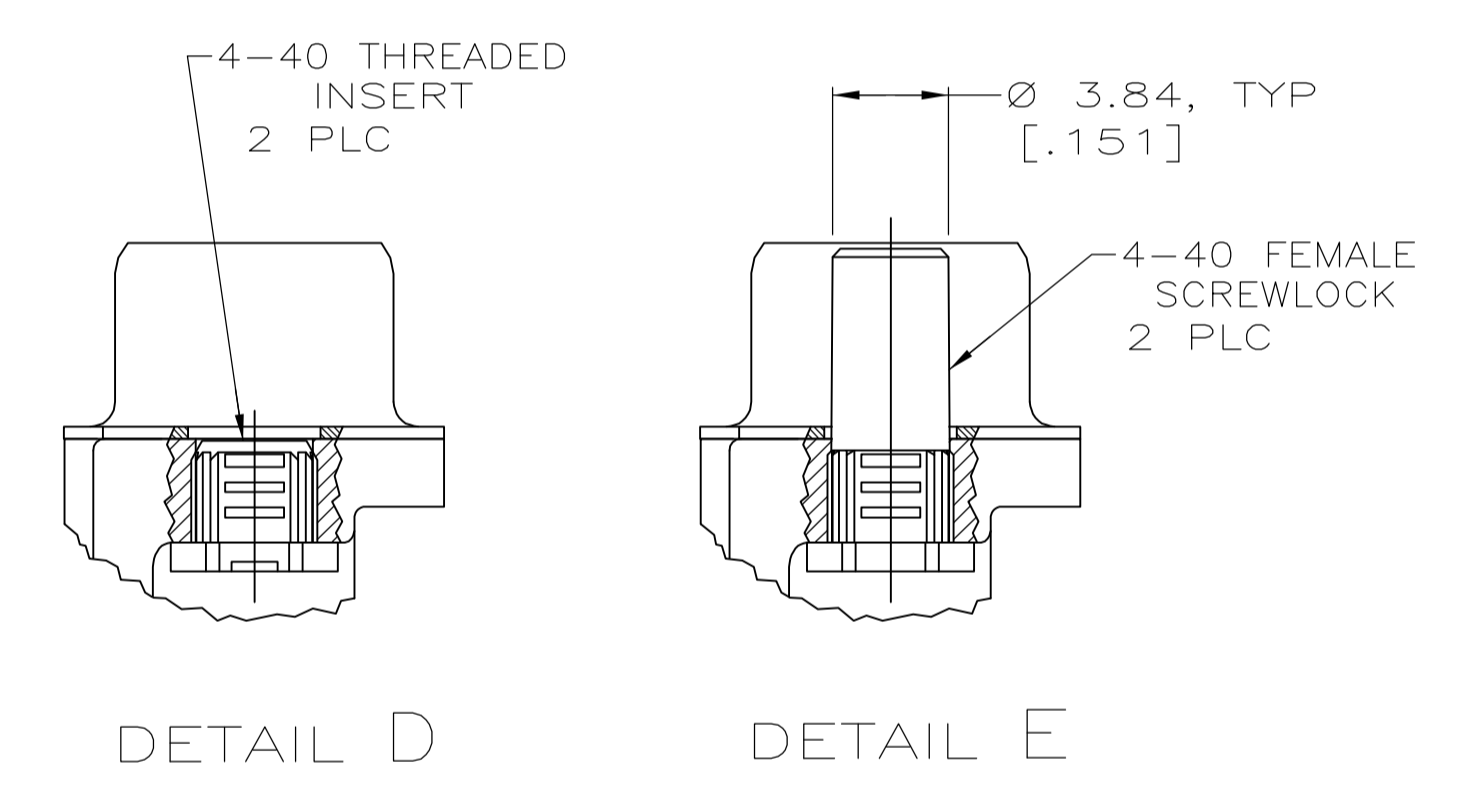
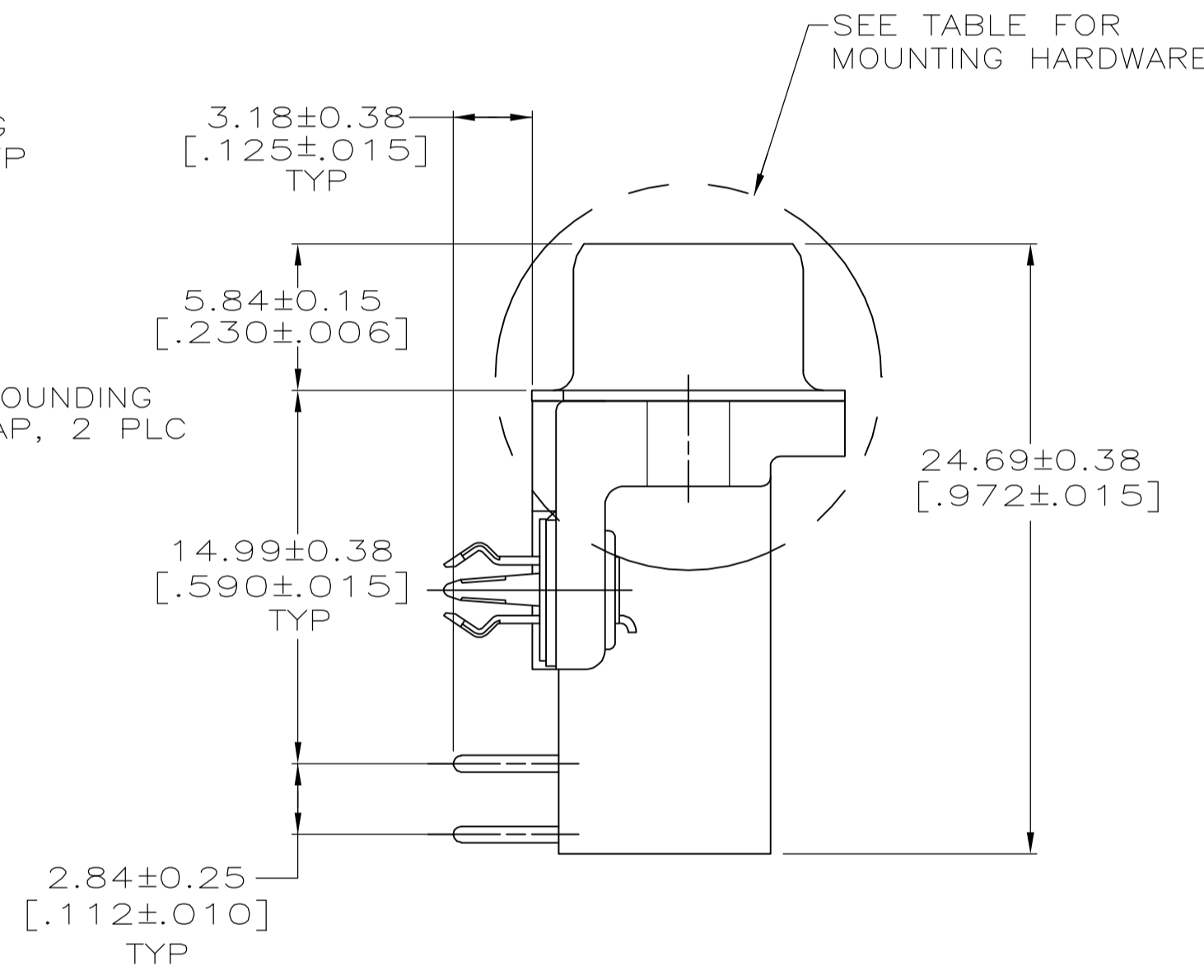
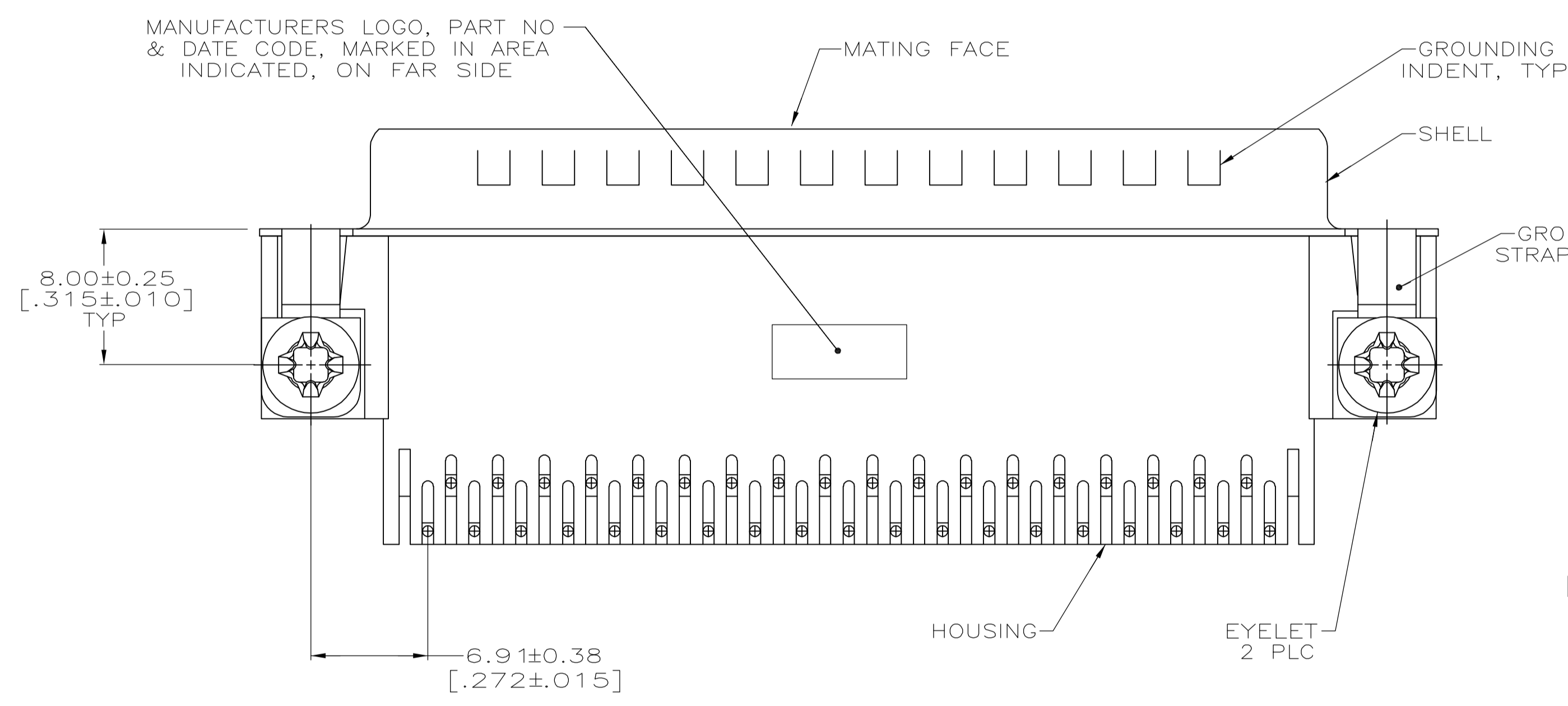
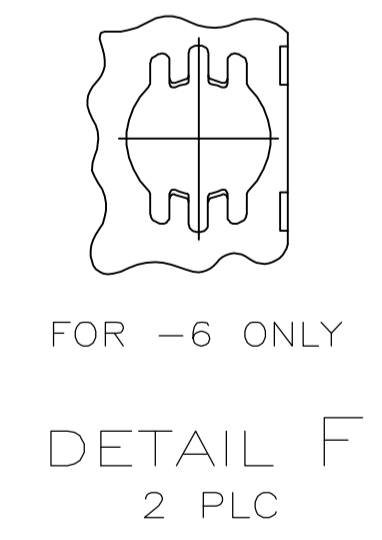

**COPYRIGHT 2005  
 TYCO ELECTRONICS CORP  
 ALL RIGHTS RESERVED**

SEE DETAIL E	5747835-6
SEE DETAIL D	5747835-4
MOUNTING HARDWARE	PART NUMBER

THIS DRAWING IS A CONTROLLED DOCUMENT.		DIN G. ATTADIA - 04-11-05		Tyco Electronics Corporation	
DIMENSIONS: mm [INCHES]		CHK S. BOLASH 04-11-05		Harrisburg, PA 17105-3608	
TOLERANCES UNLESS OTHERWISE SPECIFIED:		APVD M. WALMSLEY 04-11-05		NAME	
0 PLC ± -	1 PLC ± -	PRODUCT SPEC		PLUG ASSEMBLY, SIZE 4, 37 POSITION, RIGHT ANGLE, FRONT METAL SHELL, .590 SERIES, BOARDLOCKS, AMPLIMITE HD-20	
2 PLC ± -	3 PLC ± 0.13[.005]	APPLICATION SPEC		108-40025	
4 PLC ± -	ANGLES ± ± 2°	SIZE		114-40010	
MATERIAL	FINISH	WEIGHT		CAGE CODE DRAWING NO	
		A1		00779	
CUSTOMER DRAWING		SCALE 4:1		SHEET 1 OF 1	