

LOC		DIST		P		F		ZONE		LTR		REVISIONS			
BD	48											DESCRIPTION	DATE	APPD	
												0	RELEASED -4 PER NPR 4777, WAS 93-4930-1-1	06/07/93	-
												A	REV PER EC 0020-309-95	05/04/95	JS
												B	REV PER EC 0020-881-95	25 AUG 95	JS
												C	REV PER EC 0640-120-98	01 MAY 98	JK

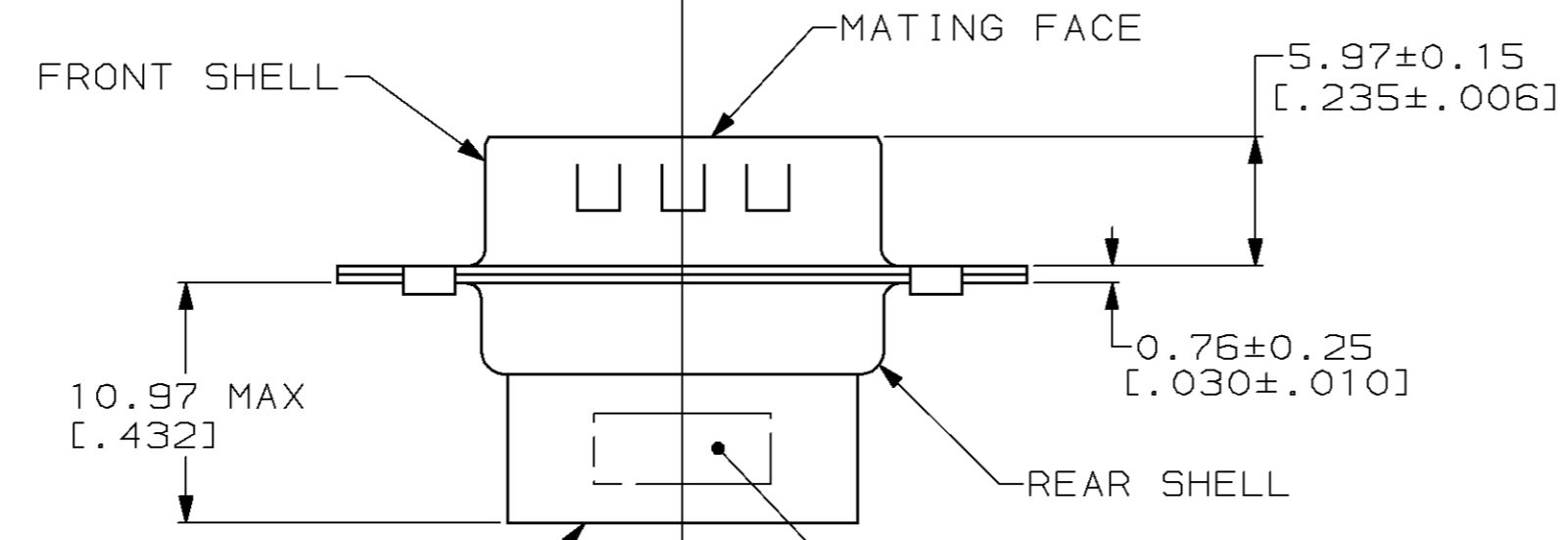

REAR INSERT
 AMP, PART NO & DATE CODE, MARKED IN AREA INDICATED, ON FAR SIDE

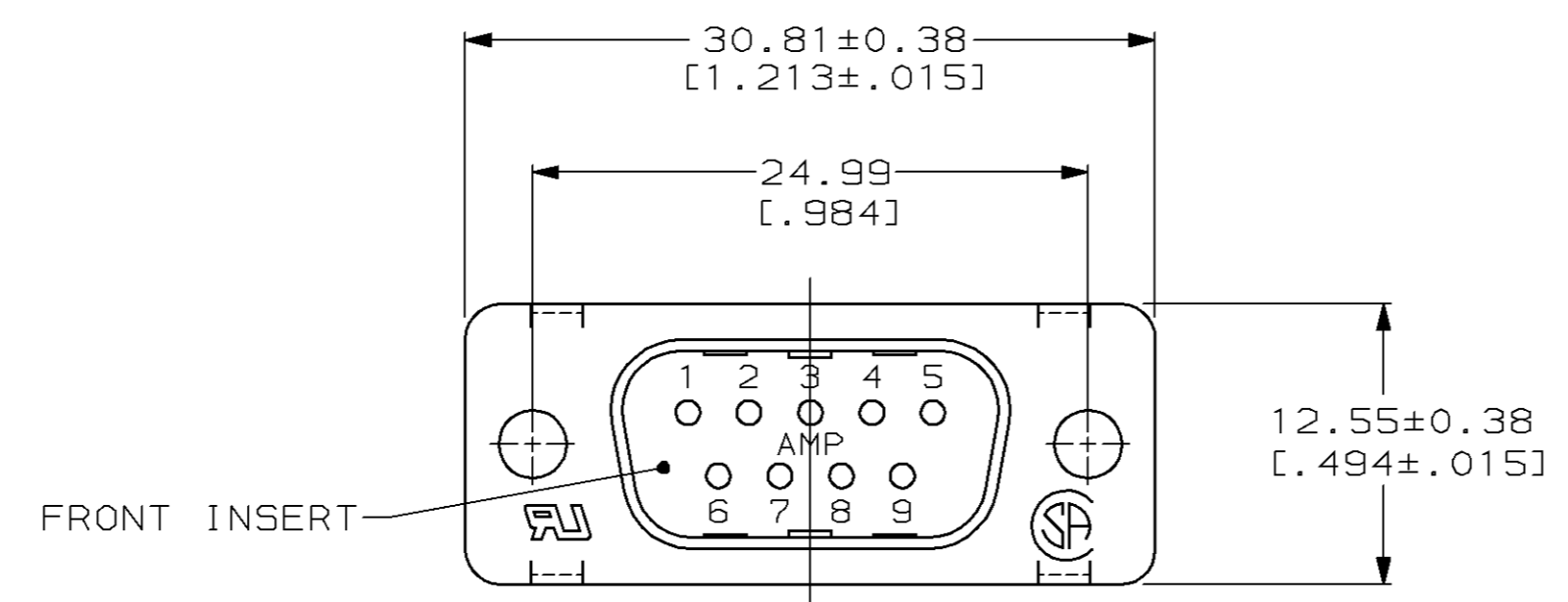
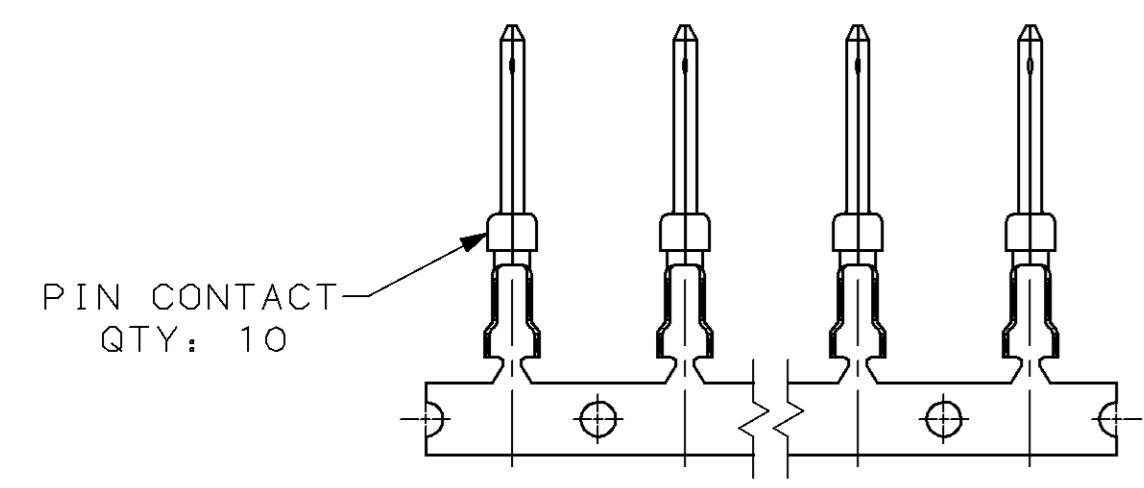
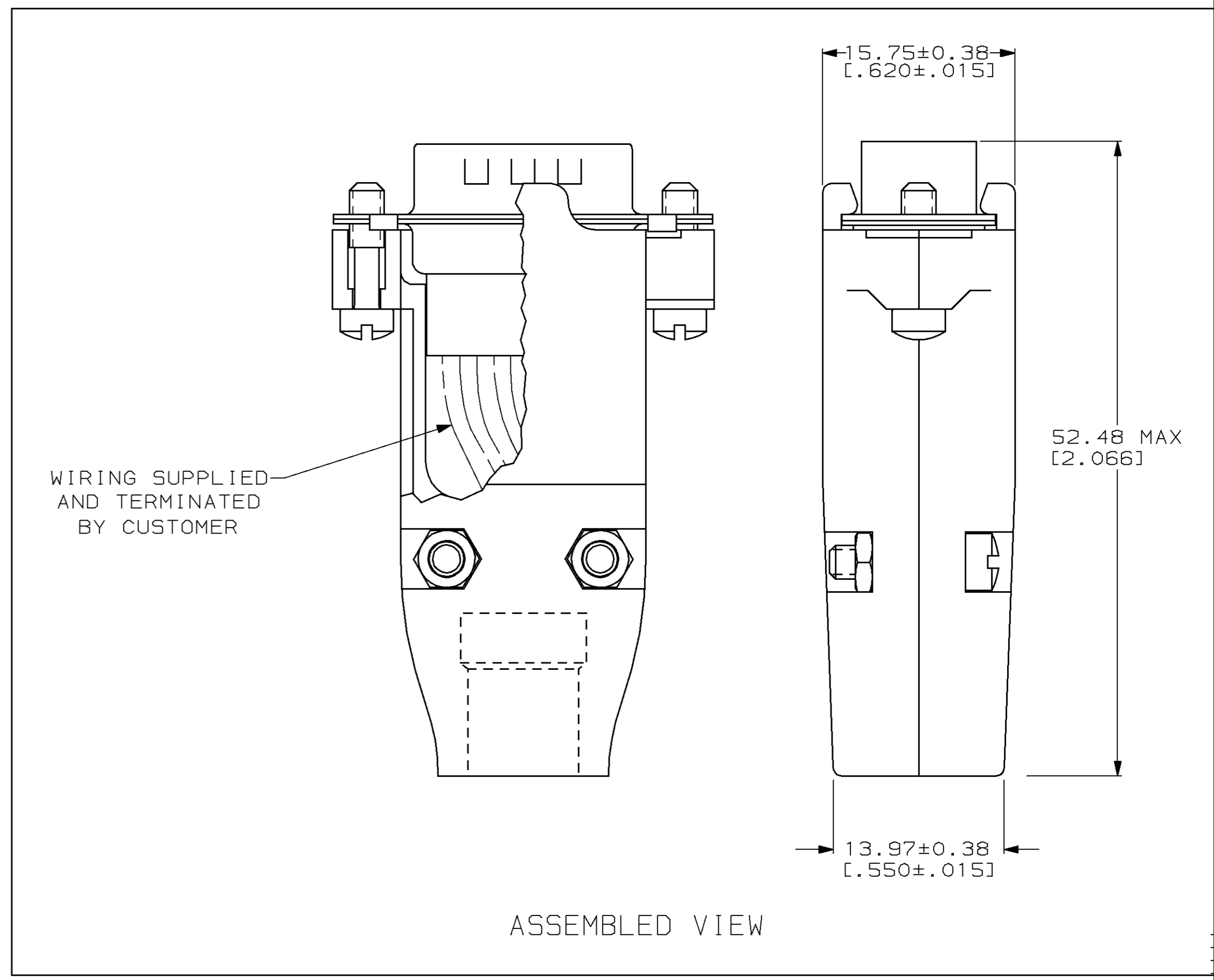
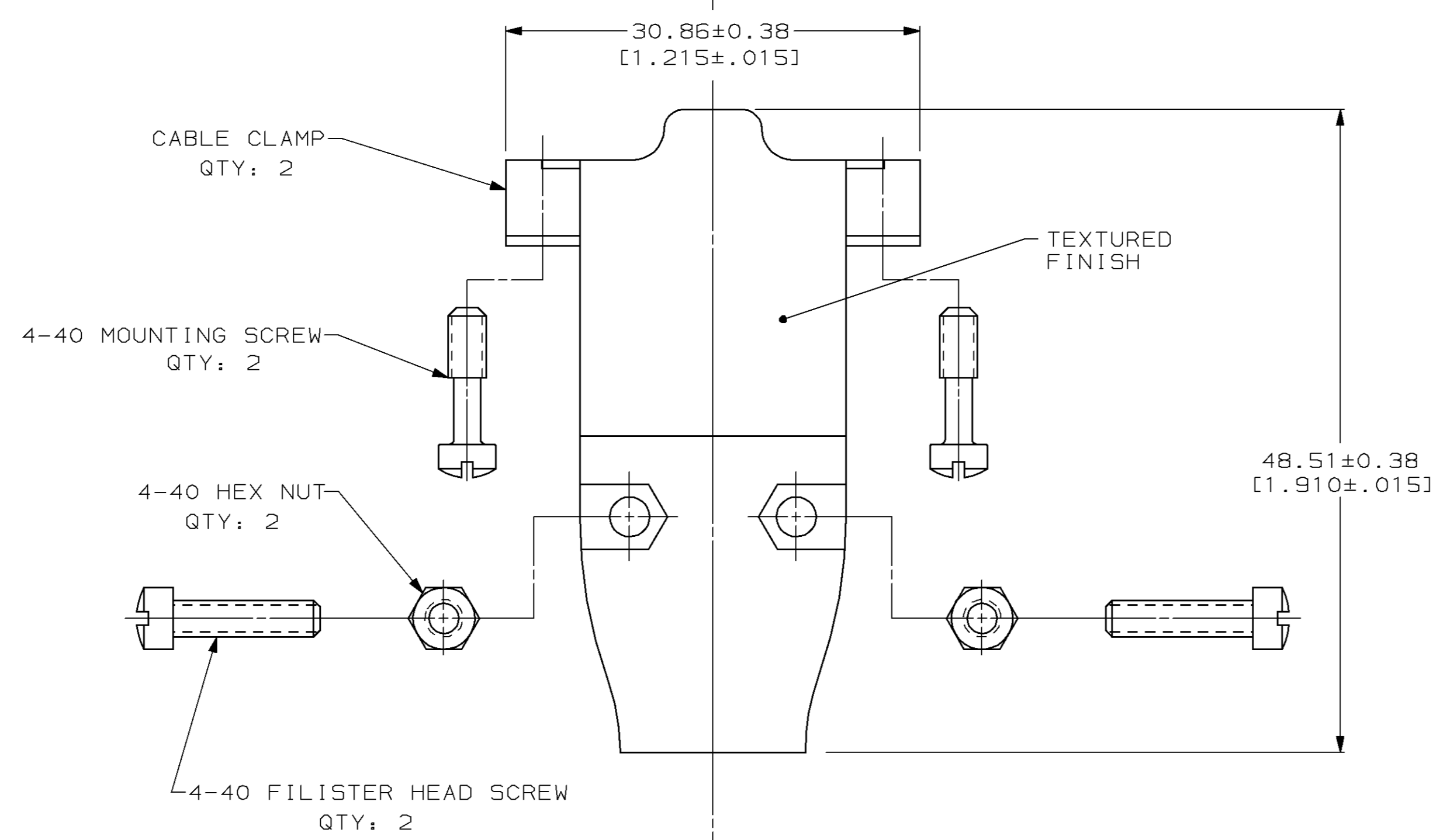
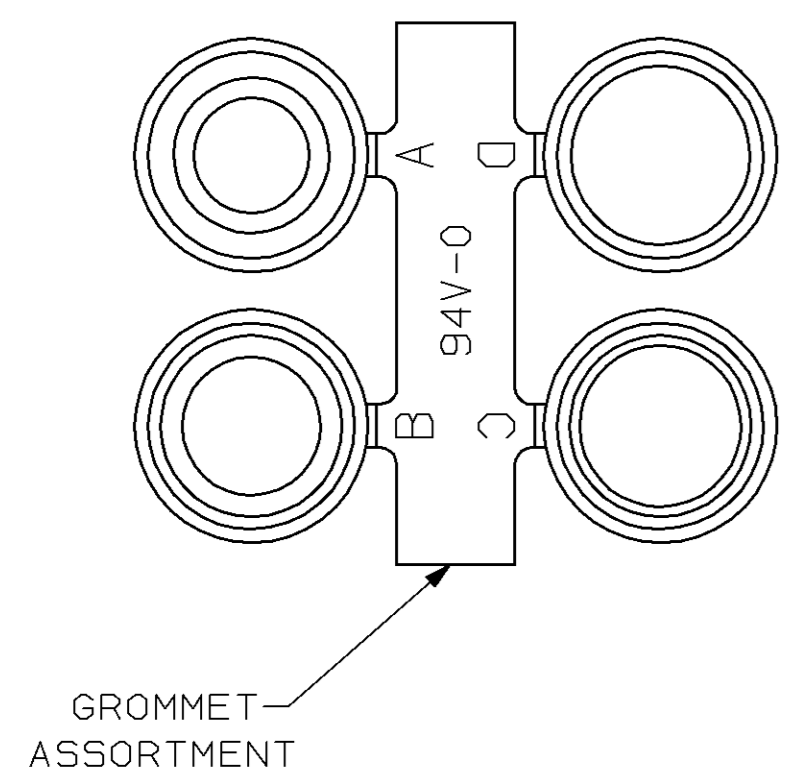

1. CONTACTS ACCEPT 24-20 AWG RANGE.
2. NYLON, GLASS FILLED, UL 94V-0 RATED, BLACK.
3. PVC, UL 94V-0 RATED, BLACK.
4. BRASS.
5. CARBON STEEL.
6. CABLE CLAMPS: ZINC; SCREWS & NUTS: CARBON STEEL.
7. GOLD PLATING PER MIL-G-45204; NICKEL PLATING PER QQ-N-290; TIN PLATING PER MIL-T-10727; COPPER PLATING PER MIL-C-14550; ZINC PLATING PER ASTM B633, TYPE III, CLASS SC1, CLEAR CHROMATE.
8. GOLD FLASH FOR A LENGTH OF 3.81 [.150] MIN FROM MATING END, 2.54µm [.000100] MIN TIN OR TIN-LEAD ON OPPOSITE END FOR A LENGTH OF 4.06 [.160] MIN FROM END OF INSULATION BARREL, BOTH OVER 0.76µm [.000030] MIN NICKEL ON ENTIRE CONTACT.
9. 5.08µm [.000200] MIN TIN OVER 1.27µm [.000050] MIN COPPER.
10. MOUNTING SCREWS & NUTS: 3.81µm [.000150] MIN ZINC; FILISTER HEAD SCREWS: ZINC.

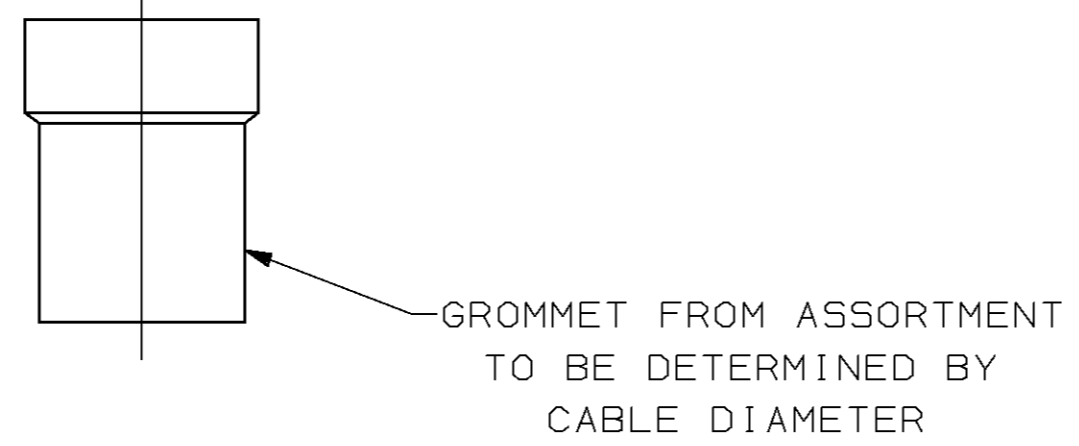

THIS DRAWING IS A CONTROLLED DOCUMENT FOR AMP INCORPORATED. IT IS SUBJECT TO CHANGE AND THE CONTROLLING ENGINEERING ORGANIZATION SHOULD BE CONTACTED FOR THE LATEST REVISION.

DO NOT SCALE PRINT. UNLESS SPECIFIED DIMENSIONS IN mm [INCHES] TOLERANCES ON:		DR 06/07/93 D. GELTZ	SMALL PACK		749805-4
2 PLC DEC ±0.13 [.005]	3 PLC DEC ± -	CHK 6-17-93 R. STONE	PACKAGING TYPE		PART NO
ANGLES ± -		APPD 6-25-93 S. BRINSER	AMP Incorporated Harrisburg, PA 17105-3608		
		APPD 6-25-93 S. BRINSER			
MATERIAL	INSERTS: 2	PRODUCT SPEC 108-40011	NAME		
GROMMETS: 3	CONTACTS: 4	APPLICATION SPEC 114-40003	PLUG KIT, UNASSEMBLED, SIZE 1, 9 POSITION, METAL SHELL, AMPLIMITE™ HDP-20		
SHELLS: 3	HARDWARE: 4	WEIGHT -	SIZE D	CAGE CODE 00779	DRAWING NO C-749805-4
FINISH 7	CONTACTS: 8		SCALE 3:1		SHEET 1 OF 1
SHELLS: 9	HARDWARE: 10		CUSTOMER DRAWING		