

LOC	DIST	P	F	ZONE	LTR	DESCRIPTION	DATE	APPR
BD	77					WAS 90-4962-1, RLSE PER NPR 3310	2-1-91	-
						REVISED PER ECN BD6112	05/14/92	MP
						REV PER ECN 0G40-429-98	17 MAR 99	RT

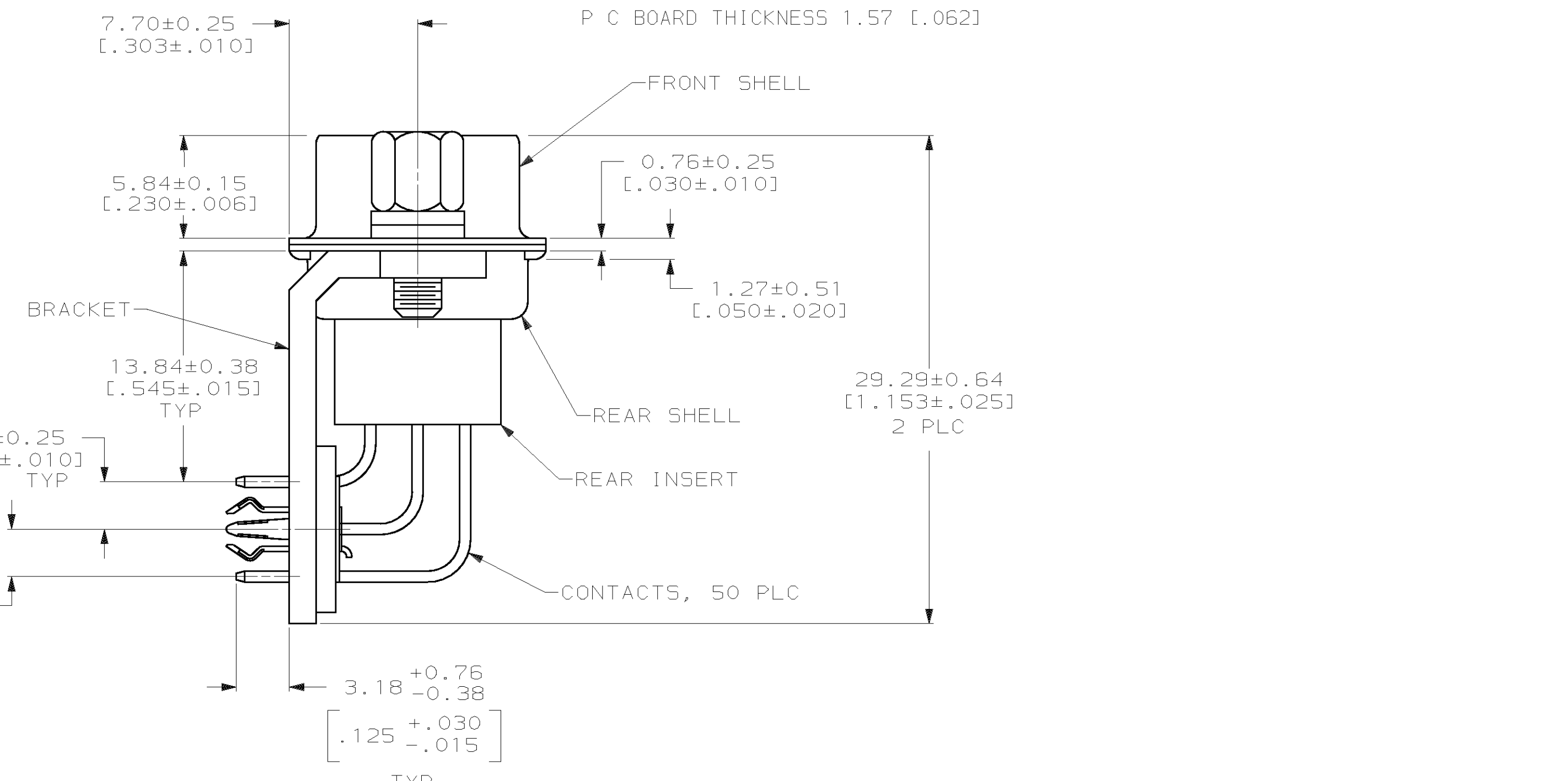
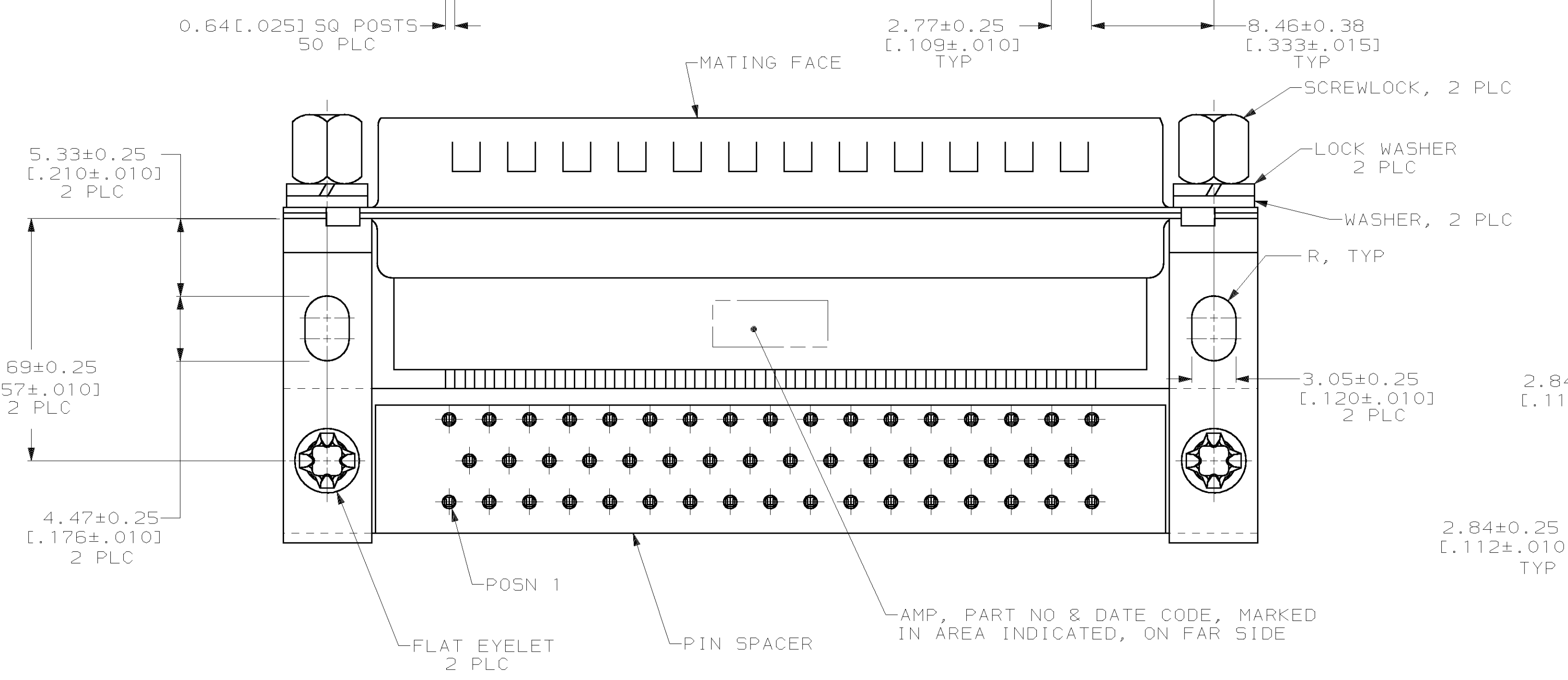
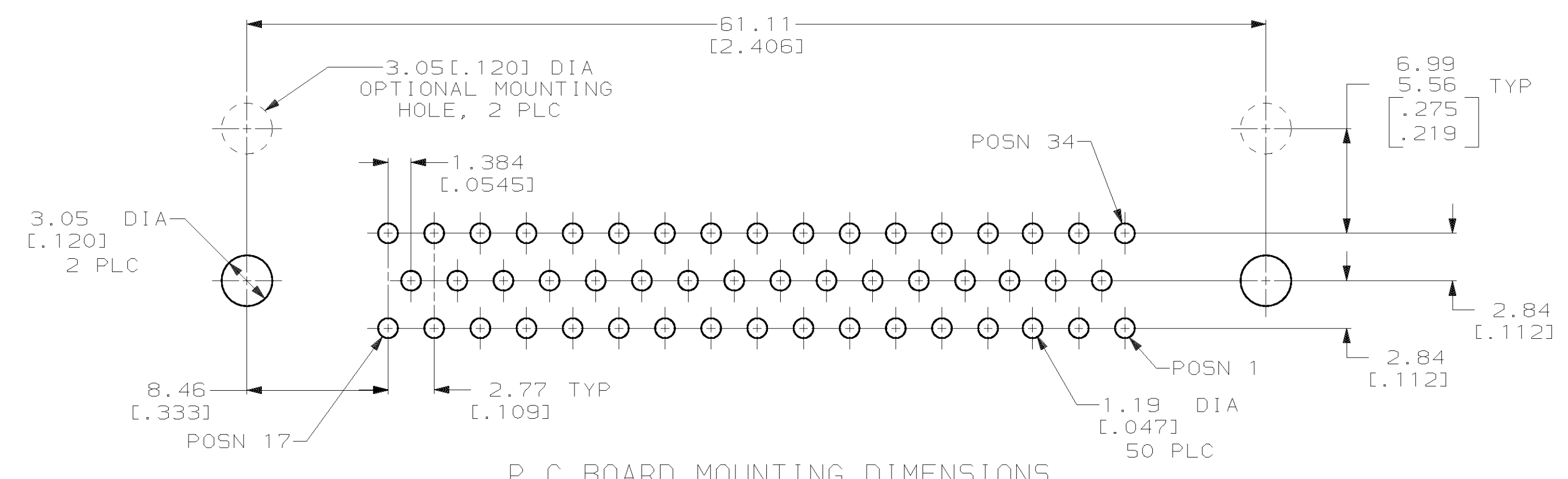
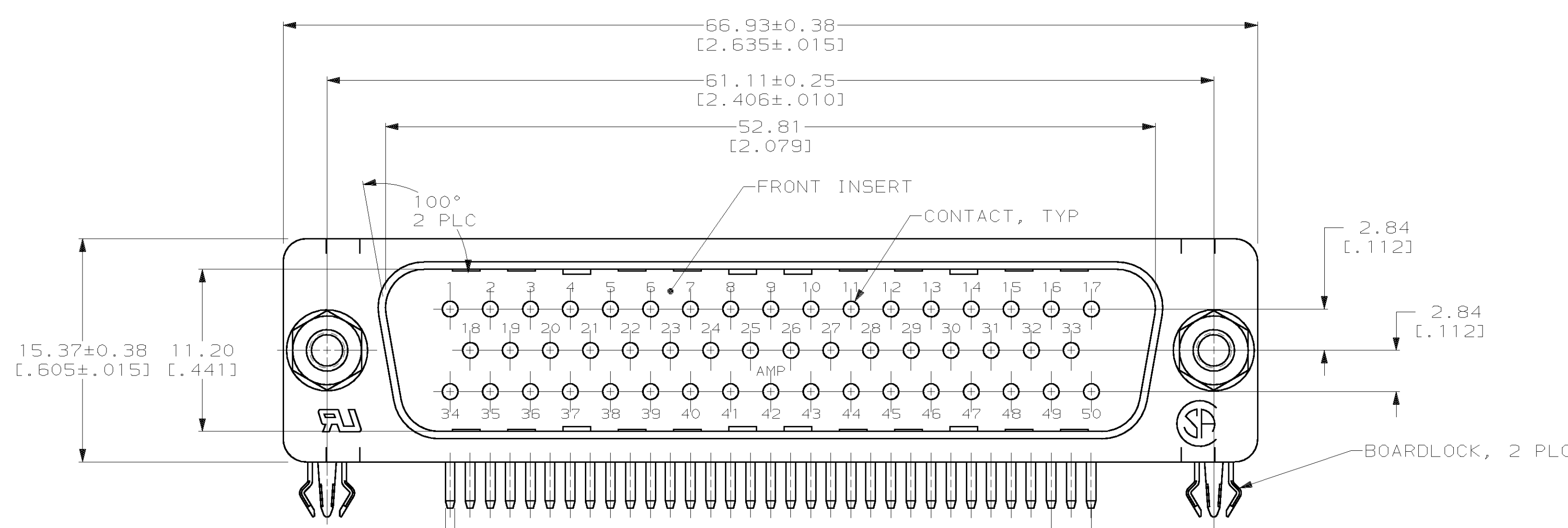

- ① NYLON OR POLYESTER, UL 94V-0 RATED, BLACK.
- ② NYLON, UL 94V-0 RATED, BLACK.
- ③ CARBON STEEL PER ASTM A109.
- ④ PHOSPHOR BRONZE PER QQ-B-750.
- ⑤ WASHERS AND SCREWLOCKS: CARBON STEEL PER ASTM A108. LOCKWASHERS: CARBON STEEL PER QQ-5-700.
- ⑥ TIN PLATING PER MIL-T-10727; GOLD PLATING PER MIL-G-45204; NICKEL PLATING PER QQ-N-290; ZINC PLATING PER ASTM B633, TYPE III, CLASS SC1, CLEAR CHROMATE; COPPER PLATING PER MIL-C-14550.
- ⑦ 5.08µm [0.000200] MIN TIN OVER 1.27µm [0.000050] MIN COPPER.
- ⑧ GOLD PLATED FOR A LENGTH OF 3.81 [0.150] MIN FROM MATING END, 0.76µm [0.000030] MIN GOLD IN MATED AREA, 2.54µm [0.000100] MIN TIN-LEAD FOR A LENGTH OF .394 [0.155] MIN ON OPPOSITE END, ALL OVER 1.27µm [0.000050] MIN NICKEL.
- ⑨ LOCKWASHERS, WASHERS & SCREWLOCKS: 5.08µm [0.000200] MIN ZINC CLEAR CHROMATE.

DO NOT SCALE PRINT. UNLESS SPECIFIED DIMENSIONS IN mm [INCHES] TOLERANCES ON:		DR 2-1-91 H MOLL		AMP AMP Incorporated Harrisburg, PA 17105-3608	
2 PLC DEC ± .005		CHK 2-7-91 J. McCLINTON			
3 PLC DEC ± .005		APPD 2-10-91 S. BURKHOLDER		NAME PLUG ASSEMBLY, SIZE 5, 50 POSN, RIGHT ANGLE, .545 SERIES, .025 50 POSTS, WITH SCREWLOCKS AND BOARDLOCKS, AMPLIMITE™ HDP	
ANGLES ± 2°		APPD 2-7-91 C. ROHDE			
MATERIAL MOLDED PARTS: ①		PRODUCT SPEC 108-40025		SIZE D CAGE CODE 00779 DRAWING NO 750365	
SHELLS & BRACKETS: ②		APPLICATION SPEC 114-40013			
CONTACTS: ④ PIN SPACER: ⑤		WEIGHT -		SCALE 4:1 SHEET 1 OF 1	
HARDWARE: ③ EYELETS: BRASS					