

REVISION					
ZONE	LTR	ECN	DESCRIPTION	DATE	APPROVED
	C	38898	UPDATE MKING & EPOXY NOTES	4/29/77	[Signature]

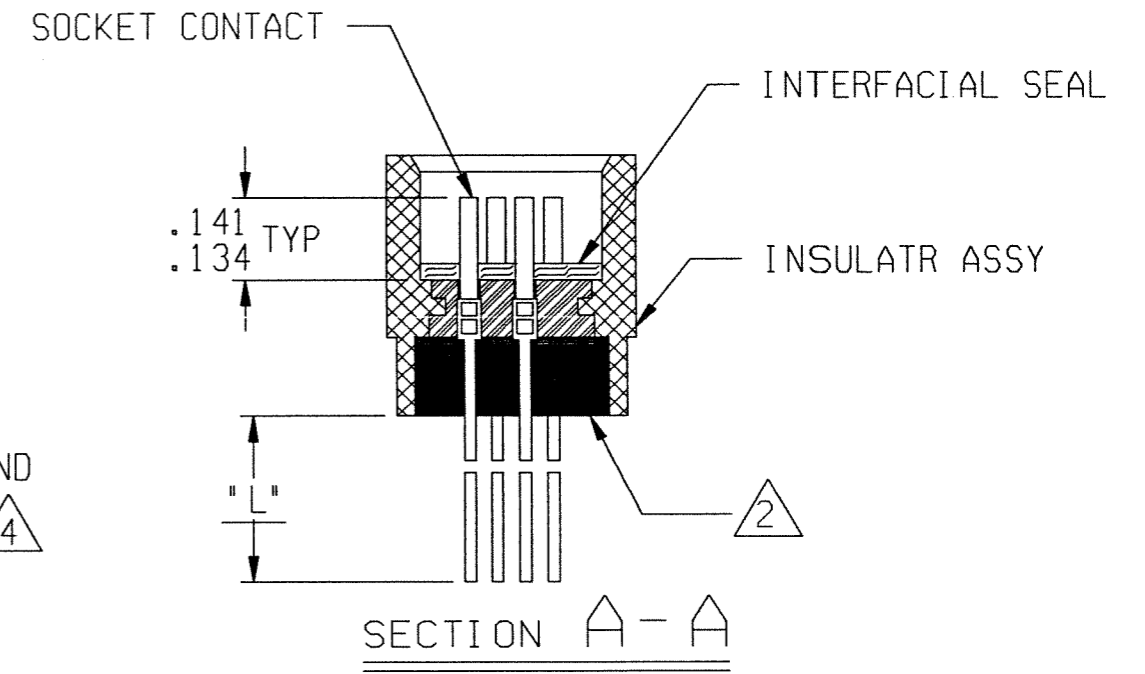
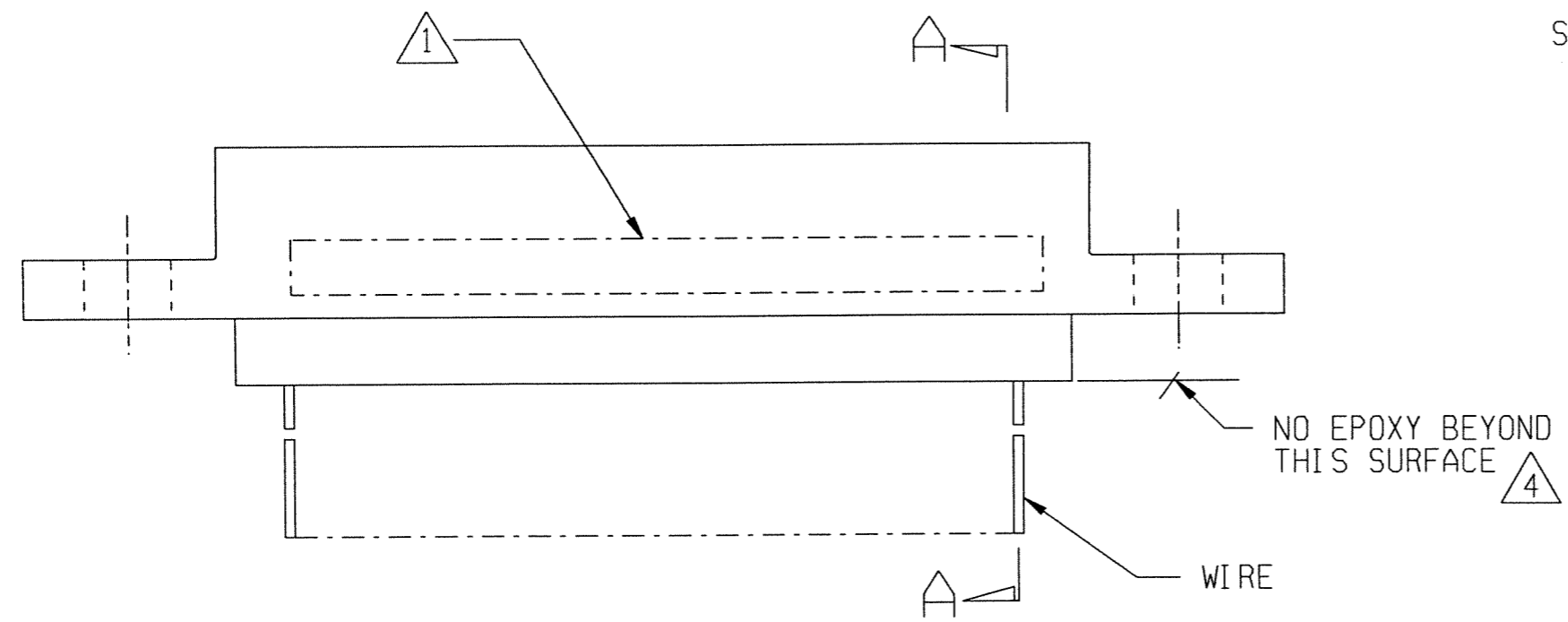
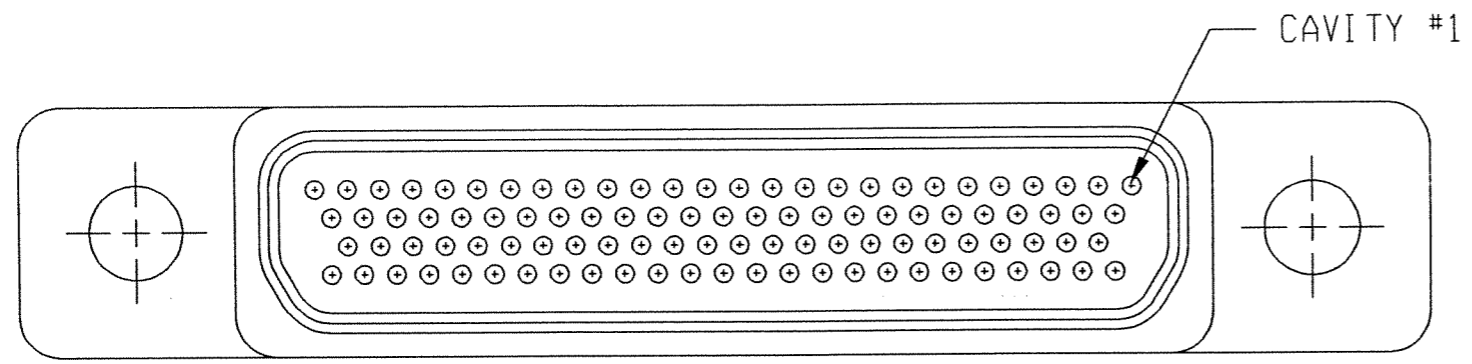

NOTES: UNLESS OTHERWISE SPECIFIED.

- 1 MARK PER TIS.
- 2 EPOXY AS SHOWN USING 194-8102-6215/6225.
- 3. CRIMP LEADS INTO CONTACTS PER MEP302-05.
- 4 EPOXY WICKING: UNINSULATED WIRE: .050 MAX.
INSULATED WIRE UPTO #25 AWG: .125 MAX.
INSULATED WIRE #24 AWG OR LARGER: .200 MAX.

Tyco Dwg 7-1532141-6
Micro P/N 094-0000-0015

UNLESS OTHERWISE SPECIFIED DIMENSIONS ARE IN INCHES. TOLERANCE ARE: FRACTIONS DECIMALS ANGLES ± 1/8 .XX ± .01 ± 2° MATERIAL: FINISH:	APPROVALS		MICRODOT CONNECTORS A DIVISION OF UNI-STAR INDUSTRIES INC. 306 PASADENA AVE., SO. PASADENA, CA 91030	PROD CODE 845	
	SIGNATURE	DATE			METAL "D" CONNECTOR MCK-XX-XX-100S-X MCK 100 RCPT. MASTER
	DRAWN BY <i>J. CHU</i>	<i>4/29/77</i>	SIZE	CODE IDENT NO.	
			B	98278	094-0000-0015
	THIS DOCUMENT IS THE PROPERTY OF MICRODOT CONNECTORS, A DIVISION OF UNI-STAR INDUSTRIES INC. USE OF THIS DOCUMENT OR ANY PART THEREOF IS STRICTLY FORBIDDEN WITHOUT THE EXPRESS WRITTEN PERMISSION OF MICRODOT CONNECTORS, A DIVISION OF UNI-STAR INDUSTRIES INC.		SCALE: NONE	SHEET 1 OF 1	