

REVISION

ZONE	LTR	ECN	DESCRIPTION	DATE	APPROVED
	B	40164	UPDATE 'TEMPLATE'.	5/1/00	me

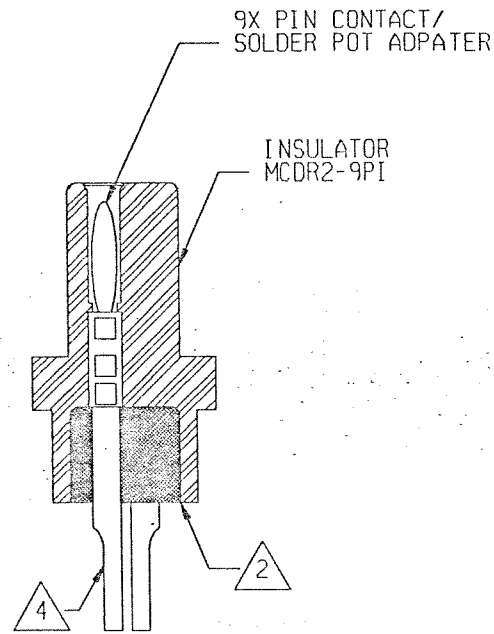
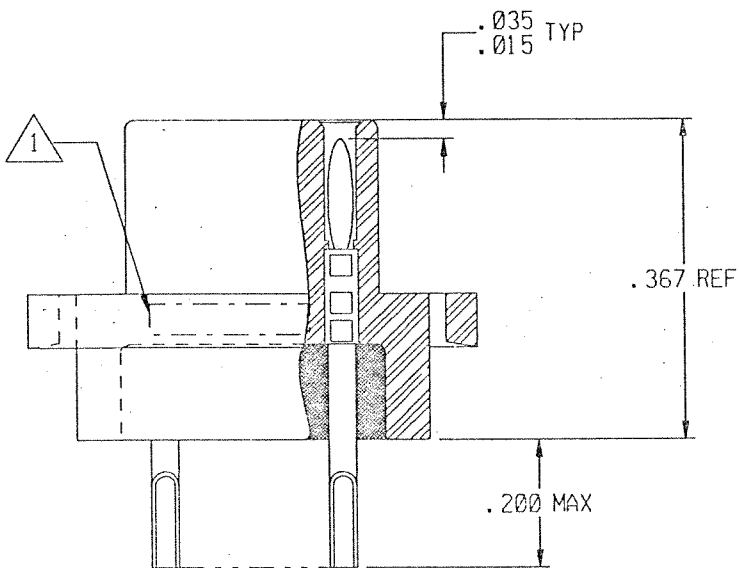
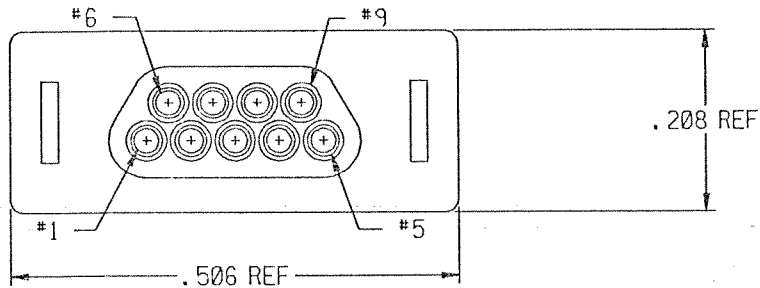

Tyco Dwg 9-1532026-5
Micro P/N 095-9603-1004

NOTES: UNLESS OTHERWISE SPECIFIED

- 1. MARK PER TIS.
- 2. EPOXY AS SHOWN WITH P/N: 194-8102-6215/6225.
- 3. CRIMP SOLDER ADAPTER INTO CONTACT PER MEP302-05.
- 4. CHAMFER ON SOLDER POTS ARE TO BE PARALLEL WITH THE SIDES OF CONNECTOR WITHIN 10°.

UNLESS OTHERWISE SPECIFIED DIMENSIONS ARE IN INCHES. TOLERANCE ARE: FRACTIONS DECIMALS ANGLES ± 1/8 .XX ± .01 ± 2° .XXX ± .005 BREAK EDGES = .005 MAX	APPROVALS		MICRODOT CONNECTORS A DIVISION OF UNI-STAR INDUSTRIES INC. 386 PASADENA AVE., SO. PASADENA, CA 91103	PROD CODE 824 CODE M
	SIGNATURE	DATE		
MATERIAL:	DRAWN BY	Tonye	5/1/00	
	P.E.	M. G. G.	S. I. G.	
FINISH:	H.E.			
	O.A.			
THIS DOCUMENT IS THE PROPERTY OF MICRODOT CONNECTORS, A DIVISION OF UNI-STAR INDUSTRIES INC. USE OF THIS DOCUMENT OR ANY PART THEREOF IS STRICTLY FORBIDDEN WITHOUT THE EXPRESS WRITTEN PERMISSION OF MICRODOT CONNECTORS, A DIVISION OF UNI-STAR INDUSTRIES INC.		SIZE	CODE IDENT NO.	DRAWING NO.
		A	98278	095-9603-1004
		SCALE: NONE	FILENAME: 09596031004	SHEET 1 OF 1

4

1

3

2

1