

- 1 MOLDED PARTS: FLAME RETARDANT 94V-0 RATED THERMOPLASTIC, BLACK. SHELLS & BRACKETS: CARBON STEEL PER ASTM A109. CONTACTS: PHOS BRONZE PER QQ-B-750.
- 2 ZINC PLATING PER ASTM B633; TYPE II; CLASS SC1; YELLOW CHROMATE, GOLD PLATING PER MIL-G-45204, NICKEL PLATING PER QQ-N-290. SHELLS & BRACKETS: ZINC PLATED. CONTACTS: GOLD (SEE TABLE) FOR A LENGTH OF 2.54 [1.00] FROM MATING END, 2.54µm [1.000100] MIN TIN-LEAD ON SOLDER END, 1.27µm [1.000050] MIN NICKEL ALL OVER.

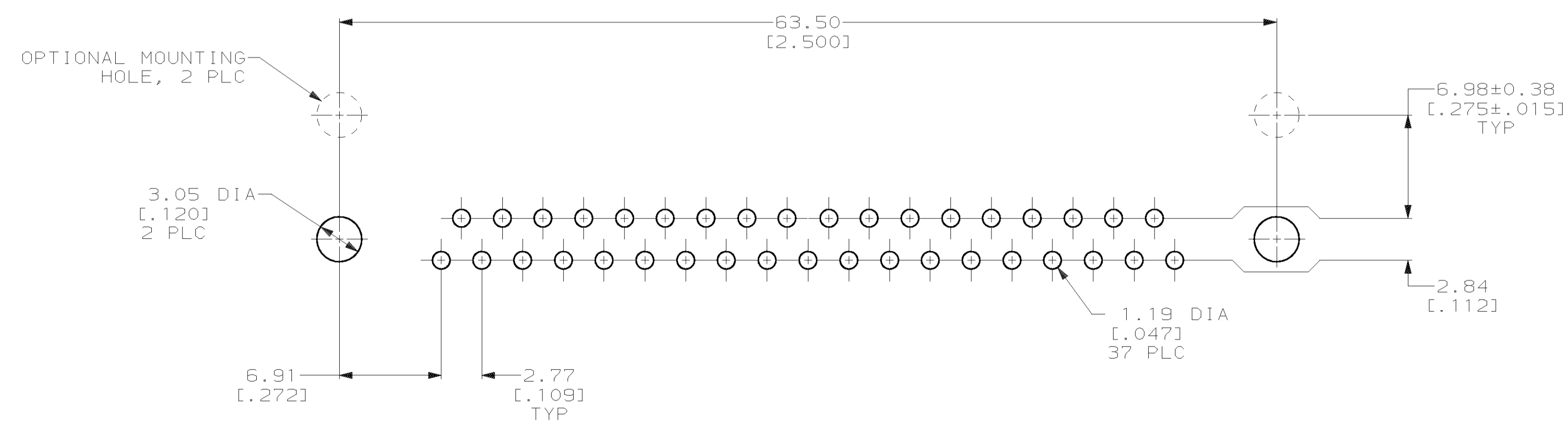
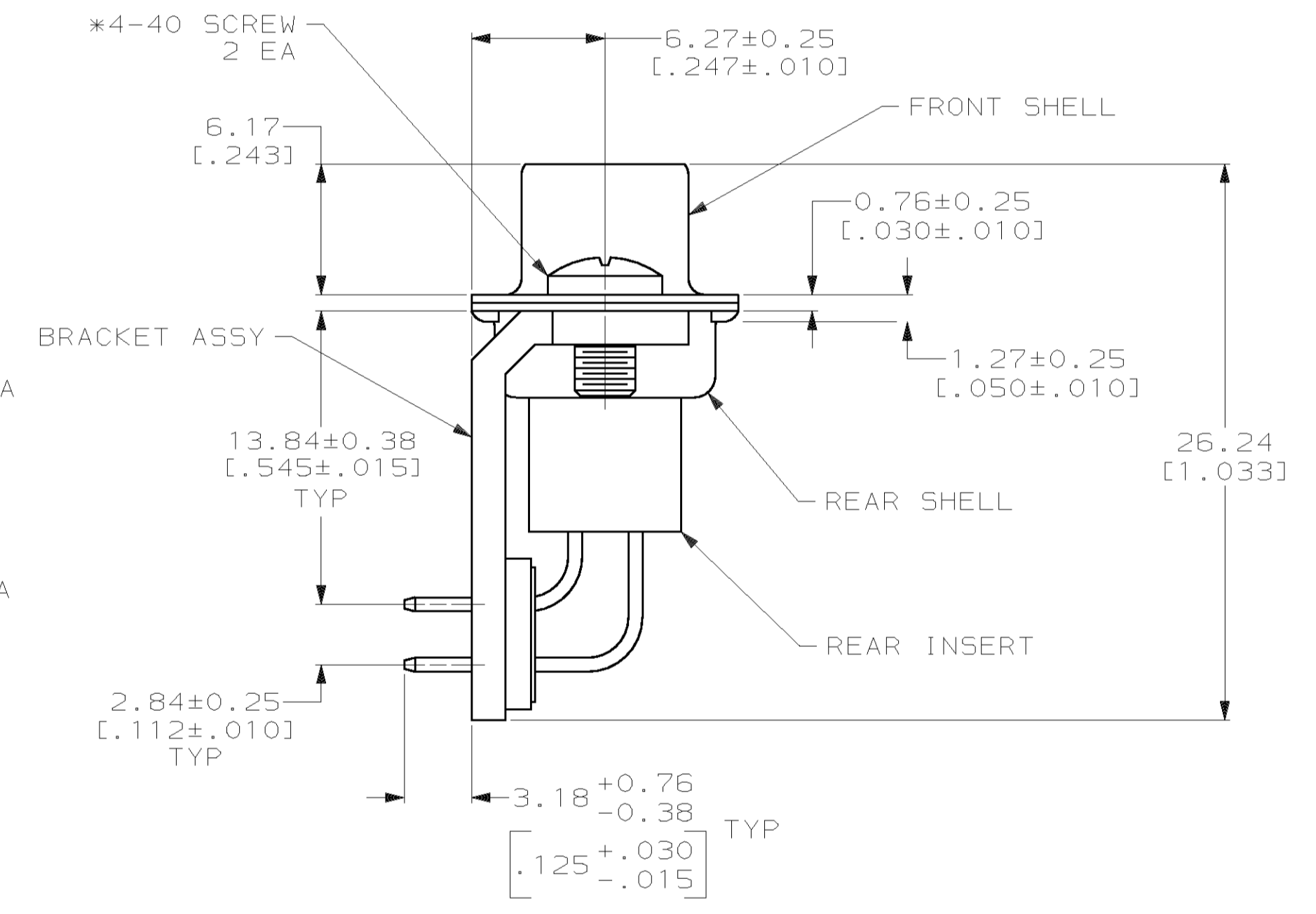
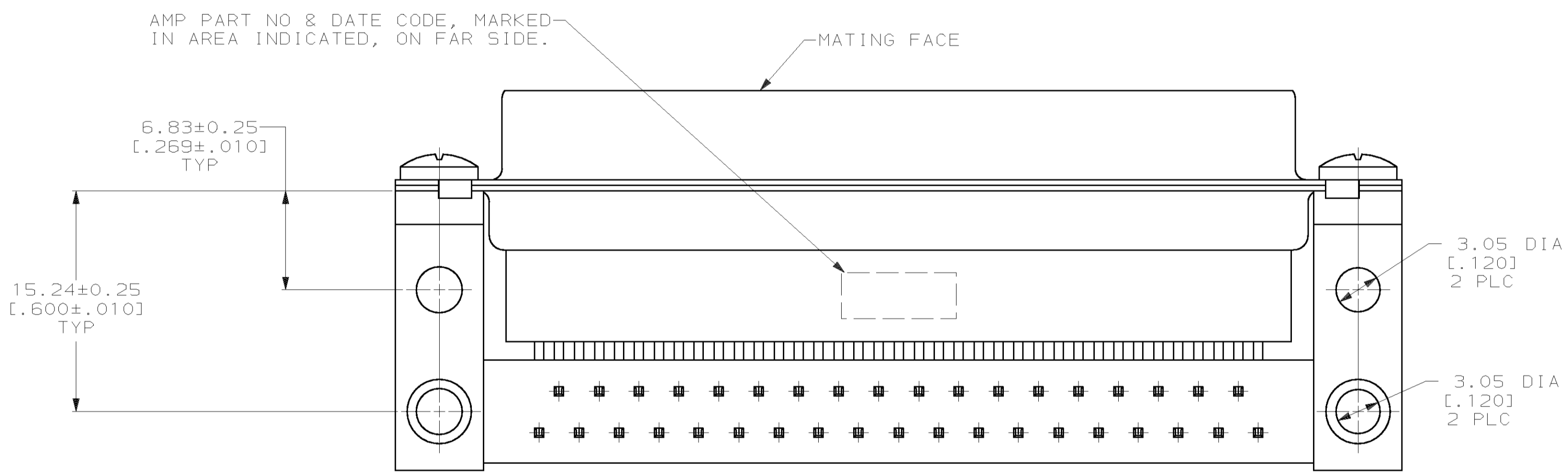

PC BOARD MOUNTING DIMENSIONS

OBSOLETE	0.76µm [2.000030]	205860-2
	FLASH	205860-1
	GOLD FINISH	PART NUMBER

<small>THIS DRAWING IS A CONTROLLED DOCUMENT FOR AMP INCORPORATED. IT IS SUBJECT TO CHANGE AND THE CONTROLLING ENGINEERING DEPARTMENT SHALL BE CONTACTED FOR THE LATEST REVISION.</small>		DWN: C. REIFSNYDER 08 AUG 95 CHK: R. STONE 23 AUG 95 APP'D: R. TAYLOR 23 AUG 95	AMP Incorporated Harrisburg, PA 17105-3608
DIMENSIONS: mm (INCHES)	TOLERANCES UNLESS OTHERWISE SPECIFIED: 0 PLC ±- 1 PLC ±- 2 PLC ±0.13 (1.005) 3 PLC ±- 4 PLC ±- ANGLES 90°	NAME: RECEPTACLE ASSY, SIZE 4, 37 POS, RIGHT ANGLE, .545 SERIES, AMPLIMITE™ HDP PRODUCT SPEC: 108-40005 APPLICATION SPEC:	SIZE: A1 CAGE CODE: 00779 DRAWING NO: C-205860
MATERIAL: △	FINISH: △	WEIGHT: -	SCALE: 4:1 SHEET 1 OF 1 REV M
CUSTOMER DRAWING			