

LOC		DIST		REVISIONS			
GP	00	PLR	DESCRIPTION	DATE	DWN	APVD	
N			REVISED PER ECO-06-028083	01DEC06	JDP	EDB	

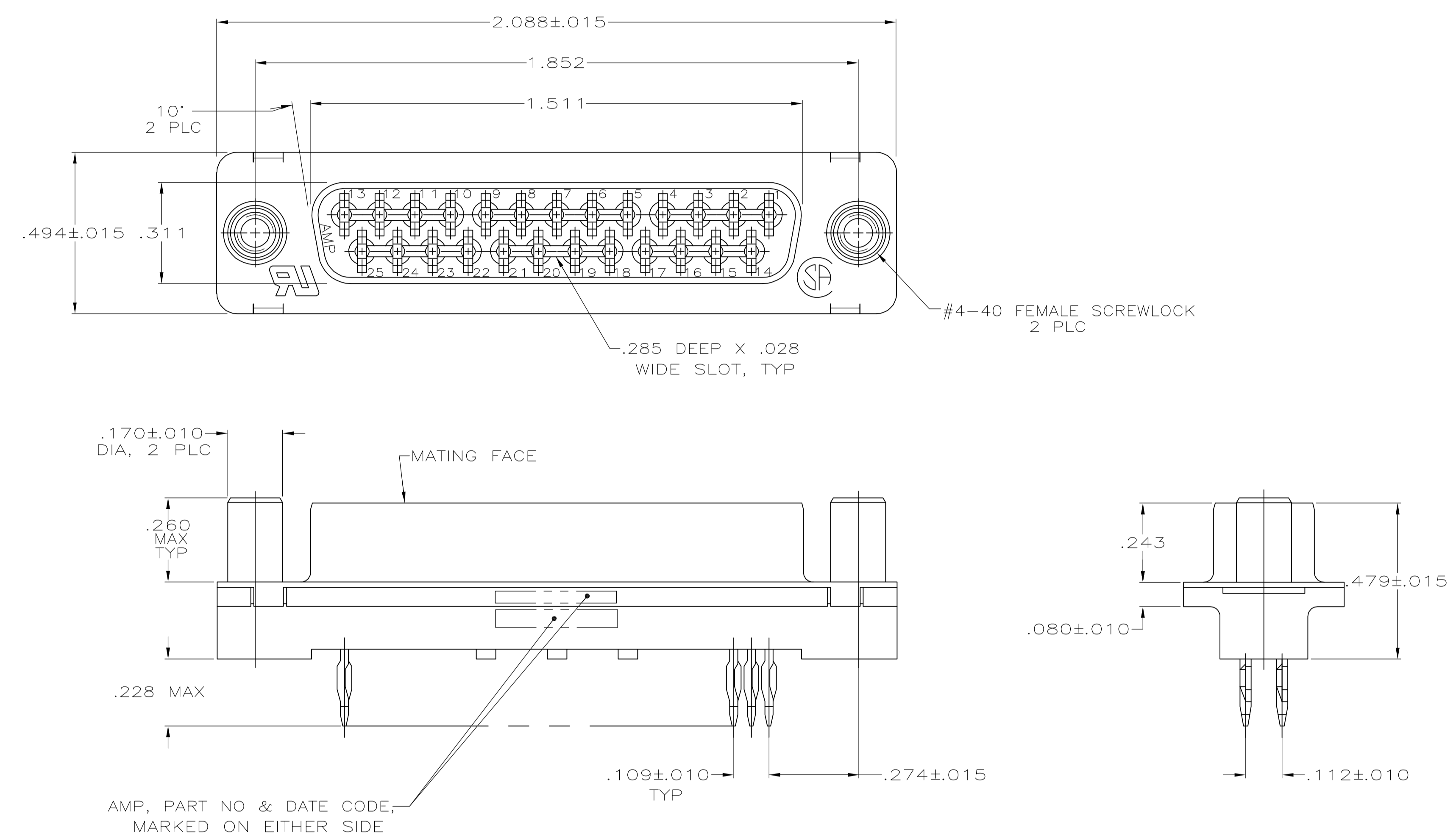

- 1 P.C. BOARD RECOMMENDATIONS:
 A. HOLES SHOULD BE DRILLED WITH A 1.15 MM DRILL.
 B. MINIMUM P.C.B. TIN-LEAD PLATING TO BE .000300 THICK OVER .002±.001 THICK COPPER.
 C. RECOMMENDED HOLE SIZE AFTER TIN-LEAD PLATING IS .037 TO .043 DIA.
 D. IF HOLE IS REFLOWED AFTER PLATING, DIA TO BE .036 TO .043.
- 2 MOLDED PARTS: FLAME RETARDANT, 94V-0 RATED, GLASS FILLED, NYLON OR POLYESTER, COLOR: BLACK.
- 3 CONTACTS: COPPER ALLOY PER ASTM B 122.
- 4 SHELL: STEEL PER ASTM A 109.
- 5 HARDWARE: ZINC ALLOY PER ASTM B 86.
- 6 GOLD PLATING PER MIL-G-45204, NICKEL PLATING PER QQ-N-290, TIN PLATING PER MIL-T-10727.
- 7 HARDWARE: SCREWLOCKS: UNPLATED.
- 8 SHELL: BRIGHT TIN PLATED.
- 9 PLATED WITH GOLD FLASH FOR A LENGTH OF .040 MIN FROM MATING END, .000100-.000200 TIN OR TIN-LEAD ON COMPLIANT PIN, ALL OVER .000030 NICKEL ON ENTIRE CONTACT.
- 10 PLATED WITH .000030 GOLD FOR A LENGTH OF .040 MIN FROM MATING END, WITH POINT OF MEASUREMENT .020 FROM MATING END OF CONTACT, .000100-.000200 TIN OR TIN-LEAD ON COMPLIANT PIN, ALL OVER .000050 NICKEL ON ENTIRE CONTACT.

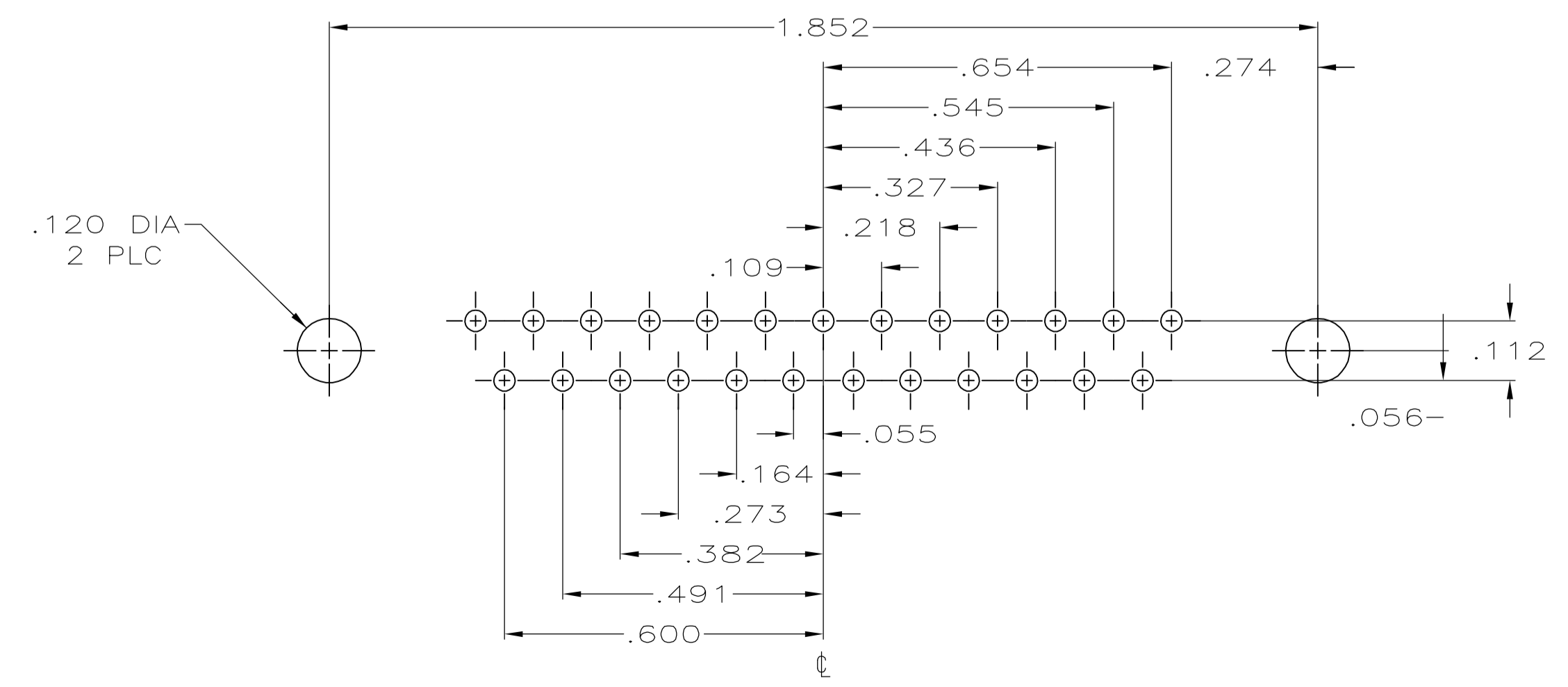

OBSELETE	CONTACT FINISH	745928-2	745928-1
		PART NO	

THIS DRAWING IS A CONTROLLED DOCUMENT.		DIN W LENKER 5-31-88	Tyco Electronics Corporation Harrisburg, PA 17105-3608
DIMENSIONS: INCHES		CHK S WELDON 6-1-88	
TOLERANCES UNLESS OTHERWISE SPECIFIED:		APVD	NAME
0 PLC ± -	1 PLC ± -	PRODUCT SPEC	RECEPTACLE ASSEMBLY, SIZE 3, 25 POSITION, WITH ACTION PIN CONTACTS, #4-40 SCREWLOCKS, FRONT METAL SHELL, MEDIUM PROFILE.
2 PLC ± -	3 PLC ± .005	APPLICATION SPEC	108-40014
4 PLC ± -	ANGLES ± °	SIZE	A1
MATERIAL	FINISH	WEIGHT	CAGE CODE DRAWING NO RESTRICTED TO
			00779 C=745928
CUSTOMER DRAWING		SCALE 4:1	SHEET 1 OF 1 REV N