

- 1 POSITION TOLERANCE APPLIES AT CONTACT TIP.
- 2 POSITION NUMBERS SHOWN FOR REFERENCE ONLY.
- 3 MATERIAL:  
HOUSING - POLYPHTHALAMIDE, BLACK, UL 94-VO RATED.  
SHELL - CARBON STEEL PER ASTM A109.  
CONTACTS - PHOSPHOR BRONZE PER QQ-B-750.  
BRACKET - ZINC
- 4 FINISH:  
SHELL - 5.08µm [.000200] MIN NICKEL OVER 1.27µm [.000050] MIN COPPER.  
BRACKET - 3.81µm [.000150] MIN NICKEL OVER 5.08µm [.000200] MIN COPPER.  
CONTACTS - EITHER 0.76µm [.000030] MIN GOLD PLATE OR GOLD FLASH OVER PALLADIUM NICKEL PLATE, 0.76µm [.000030] MIN TOTAL, FOR A LENGTH OF 0.64 [.025] MIN, 0.13 [.005] MAX FROM MATING END, 1.27µm [.000050] MIN TIN-LEAD ON OPPOSITE END FOR A LENGTH OF 7.49 [.295] MIN, BOTH OVER 1.27µm [.000050] MIN NICKEL.
- 5 PC BOARD HOLE RECOMMENDATIONS:  
A. HOLES SHOULD BE DRILLED WITH A 0.701 [.0276] DRILL.  
B. PC BOARD PLATING TO BE 7.62µm [.000300] MIN TIN-LEAD OVER 0.025-0.038 [.0010-.0015] COPPER.  
C. RECOMMENDED HOLE SIZE AFTER TIN-LEAD PLATING IS 0.56-0.66 [.022-.026].
- 6 OBSOLETE PART NUMBER.

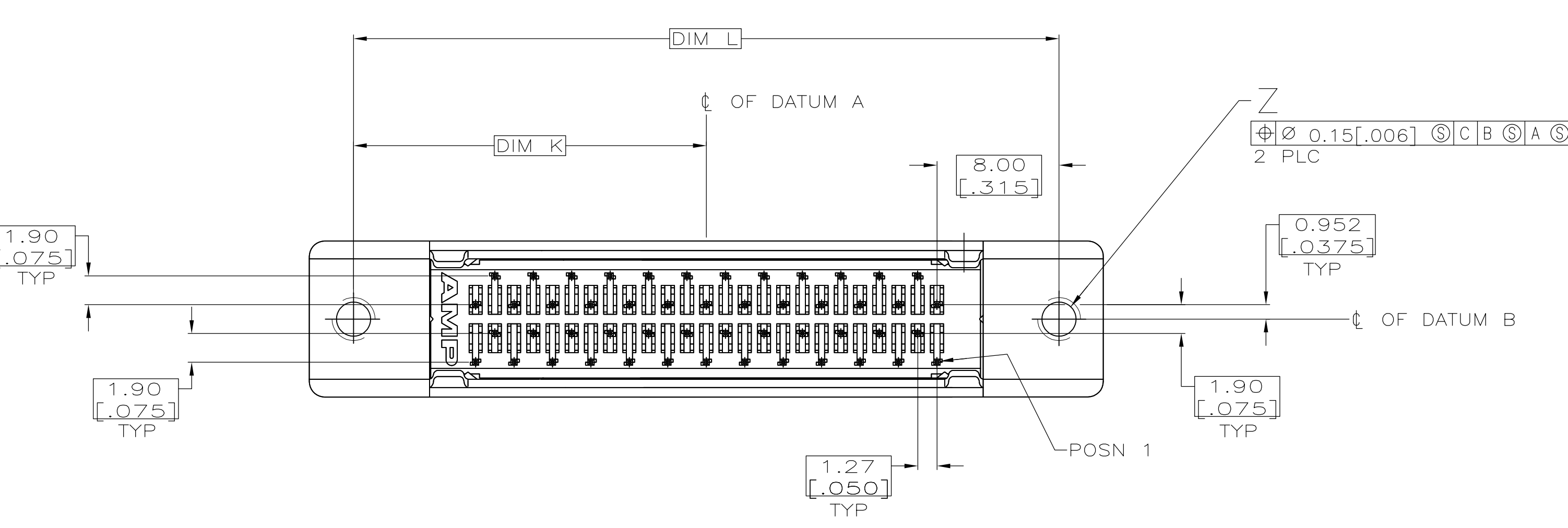

PER DETAIL	Z	R	P	N	L	K	NO OF POSN	PART NUMBER
PER DETAIL X	3.07 DIA [.121]	63.88 [2.515]	41.91 [1.650]	46.13 [1.816]	57.91 [2.280]	28.96 [1.140]	68	1-786557-2
PER DETAIL X	3.07 DIA [.121]	63.88 [2.515]	41.91 [1.650]	46.13 [1.816]	57.91 [2.280]	28.96 [1.140]	68	1-786557-1
PER DETAIL X	4-40 UNC-2B	96.90 [3.815]	74.93 [2.950]	79.15 [3.116]	90.93 [3.580]	45.47 [1.790]	120	1-786557-0
PER DETAIL X	4-40 UNC-2B	84.20 [3.315]	62.23 [2.450]	66.45 [2.616]	78.23 [3.080]	39.12 [1.540]	100	786557-9
PER DETAIL X	4-40 UNC-2B	63.88 [2.515]	41.91 [1.650]	46.13 [1.816]	57.91 [2.280]	28.96 [1.140]	68	786557-7
PER DETAIL Y	4-40 UNC-2B	52.45 [2.065]	30.48 [1.200]	34.70 [1.366]	46.48 [1.830]	23.24 [.915]	50	786557-5
PER DETAIL Y	4-40 UNC-2B	37.21 [1.465]	15.24 [.600]	19.46 [.766]	31.24 [1.230]	15.62 [.615]	26	786557-2
PER DETAIL X	4-40 UNC-2B	33.40 [1.315]	11.43 [.450]	15.65 [.616]	27.43 [1.080]	13.72 [.540]	20	786557-1
RECOMMENDED PCB MTG DIMENSIONS	Z	R	P	N	L	K	NO OF POSN	PART NUMBER

THIS DRAWING IS A CONTROLLED DOCUMENT.

DIMENSIONS: mm(INCHES)	TOLERANCES UNLESS OTHERWISE SPECIFIED:	PRODUCT SPEC	108-1228
Ø	0 PLC ± .13 [005]	APPLICATION SPEC	114-40029
	1 PLC ± .13 [005]	WEIGHT	-
	2 PLC ± .13 [005]	CUSTOMER DRAWING	
	3 PLC ± .13 [005]	SCALE	4:1
	4 PLC ± .13 [005]	SHEET	1 OF 1
	ANGLES ± .13 [005]	REV	L

**Tyco Electronics**  
 Tyco Electronics Corporation  
 Harrisburg, PA 17105-3608  
 RECEPTACLE ASSEMBLY, SHIELDED, VERTICAL, FLAT TOP, ACTION PIN FOR .125 TO .200 THICK BD.  
 SIZE: A1 CAGE CODE: 00779 DRAWING NO: 786557  
 SCALE: 4:1 SHEET: 1 OF 1 REV: L