

THIS DRAWING IS UNPUBLISHED. RELEASED FOR PUBLICATION
 © COPYRIGHT 2005 BY TYCO ELECTRONICS CORPORATION. ALL RIGHTS RESERVED.

LOC	DIST	REVISIONS			
P	LTR	DESCRIPTION	DATE	DWN	APVD
GP	00	B	REVISED PER ECO-06-028339	18/DEC/06	ZMR/EDB

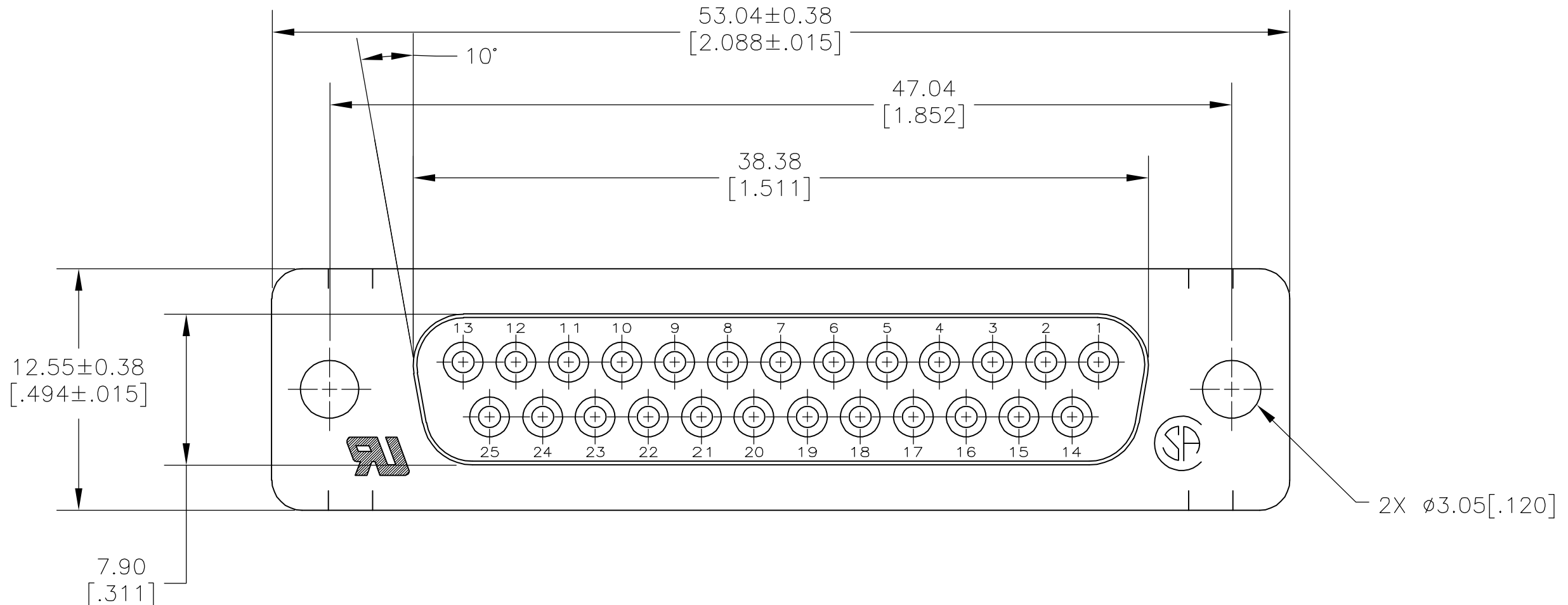

- 1 MOLDED PARTS: GLASS-FILLED NYLON, UL 94V-0 RATED, COLOR BLACK.
SHELLS: CARBON STEEL.
CONTACTS: PHOS BRONZE.
- 2 SHELLS: 5.08µm [.000200] MIN TIN OVER 2.54µm [.000100] MIN COPPER.
CONTACTS: SEE TABLE
- 3 GOLD FLASH ON MATING END, 2.54µm [.000100] MIN TIN ON SOLDER END, BOTH OVER 1.27µm [.000050] MIN NICKEL.
- 4 0.76µm [.000030] MIN GOLD ON MATING END, 2.54µm [.000100] MIN TIN ON SOLDER END, BOTH OVER 1.27µm [.000050] MIN NICKEL.
-OR-
GOLD FLASH OVER 0.76µm [.000030] MIN PALLADIUM NICKEL PLATED FOR ON MATING END, 2.54µm [.000100] MIN TIN ON SOLDER END, BOTH OVER 1.27µm [.000050] MIN NICKEL.

TYCO, PART NO & DATE CODE, MARKED IN AREA INDICATED, ON FAR SIDE

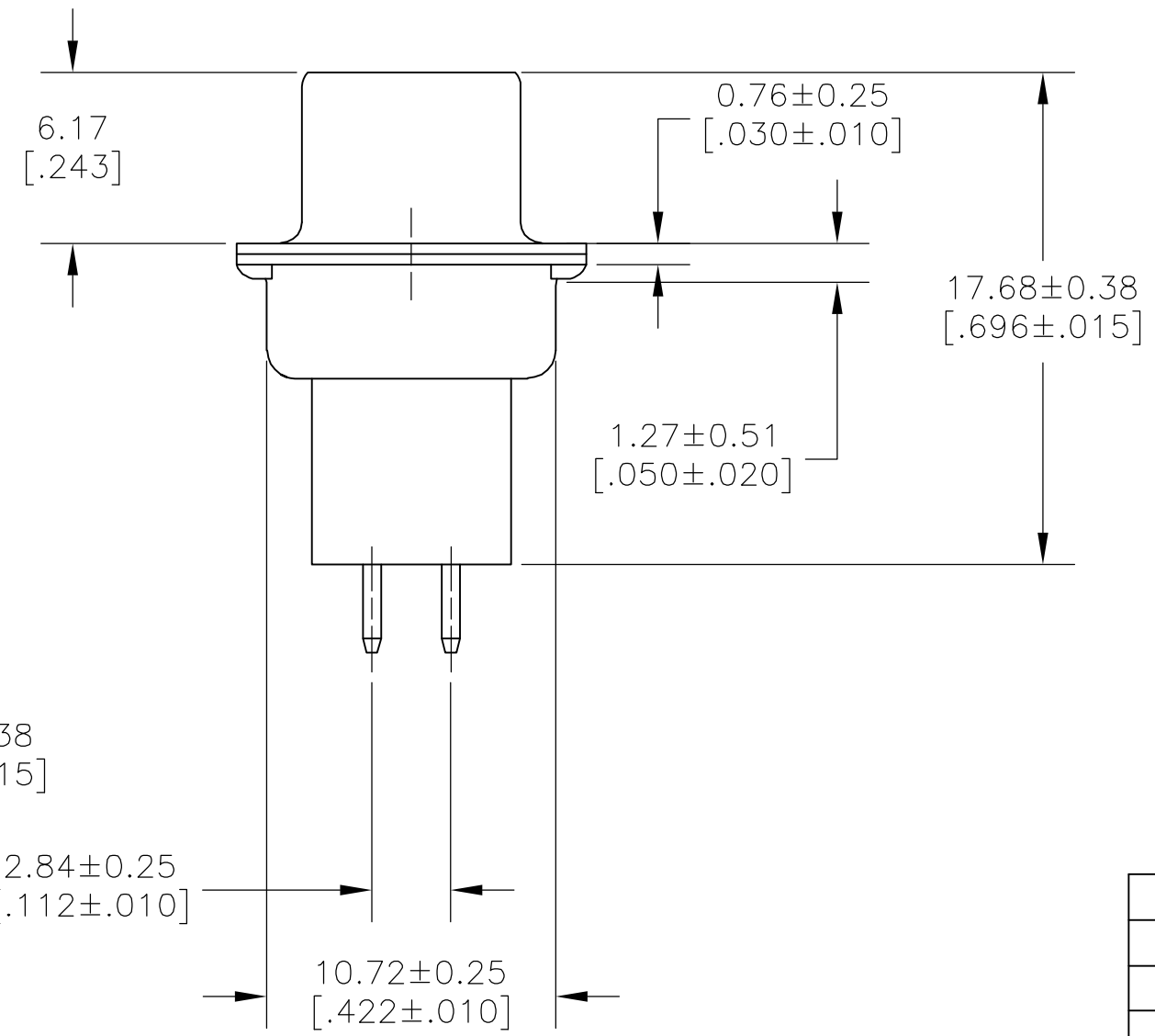
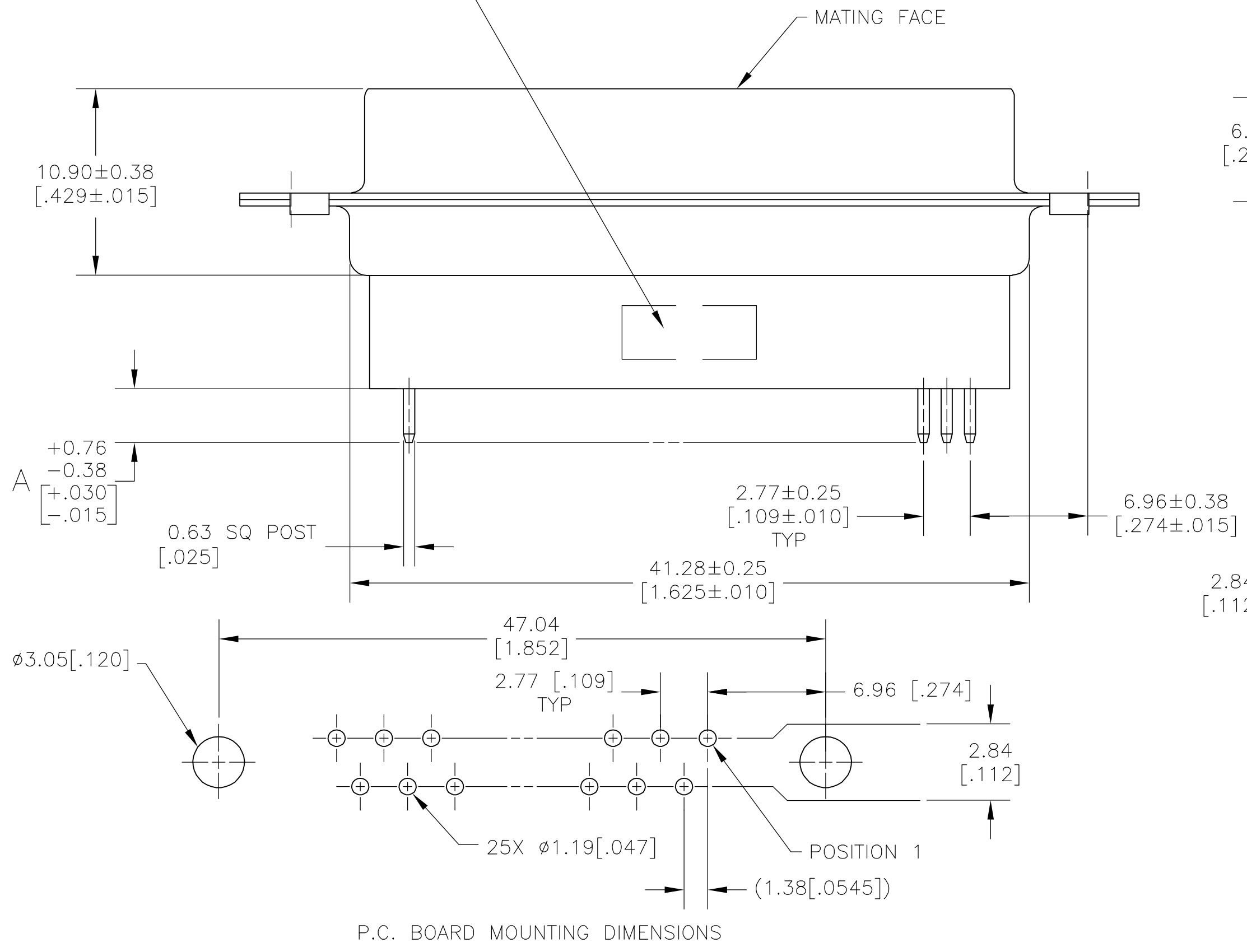

CONTACT FINISH	DIMENSION A	PART NO
3	4.77 [.188]	5745187-8
4	4.77 [.188]	5745187-7
4	10.84 [.427]	5745187-3
4	3.17 [.125]	5745187-1

THIS DRAWING IS A CONTROLLED DOCUMENT.		DWN B. LATTUCA 14SEPT05	Tyco Electronics Corporation Harrisburg, Pa 17105-3608
DIMENSIONS: mm[INCHES]		CHK S. BOLASH 14SEPT05	
TOLERANCES UNLESS OTHERWISE SPECIFIED:		APVD M. WALMSLEY 14SEPT05	
0 PLC ± - 1 PLC ± - 2 PLC ± - 3 PLC ± 0.13 [.005] 4 PLC ± - ANGLES ± 2° FINISH		PRODUCT SPEC 108-40025 APPLICATION SPEC - WEIGHT - CUSTOMER DRAWING	
NAME RECEPTACLE ASSEMBLY, SIZE 3, 25 POSITION, VERTICAL, AMPLIMITE HDP			RESTRICTED TO
MATERIAL		SCALE 4:1	SHEET 1 OF 1
MATERIAL 1 FINISH 2		SIZE A2	CAGE CODE 00779
MATERIAL 1 FINISH 2		DRAWING NO C=5745187	REV B

P.C. BOARD MOUNTING DIMENSIONS