

- △ HOUSING & FACE COVER: NYLON, THERMOPLASTIC, UL 94VO RATED, BLACK; SHELL: CARBON STEEL
 SOCKET CONTACTS: PHOSPHOR BRONZE; EYELETS: BRASS;
 THREADED INSERTS: ZINC; BOARDLOCKS: COPPER ALLOY.
- △ SOCKET CONTACTS: GOLD PLATED FOR A LENGTH OF 1.27 [.050] MIN FROM MATING END, 0.76µm [.000030] MIN GOLD IN MATED AREA, 2.54µm [.000100] MIN TIN FOR A LENGTH OF 3.56 [.140] MIN FROM OPPOSITE END, BOTH OVER 1.27µm [.000050] MIN NICKEL.
 EYELETS: 2.54µm [.000100] MIN TIN OVER COPPER FLASH.
 SHELL: 2.54µm [.000100] MIN TIN OVER 1.27µm [.000050] MIN COPPER.
 THREADED INSERTS: CLEAR CHROMATE.
 BOARDLOCKS: 3.81µm [.000150] MIN TIN OVER 1.27µm [.000050] MIN NICKEL.
- △ SOCKET CONTACTS: GOLD PLATED FOR A LENGTH OF 1.27 [.050] MIN FROM MATING END, GOLD FLASH IN MATED AREA, 2.54µm [.000100] MIN TIN FOR A LENGTH OF 3.56 [.140] MIN FROM OPPOSITE END, BOTH OVER 1.27µm [.000050] MIN NICKEL.
 EYELETS: 2.54µm [.000100] MIN TIN OVER COPPER FLASH.
 SHELL: 2.54µm [.000100] MIN TIN OVER 1.27µm [.000050] MIN COPPER.
 THREADED INSERTS: CLEAR CHROMATE.
 BOARDLOCKS: 3.81µm [.000150] MIN TIN OVER 1.27µm [.000050] MIN NICKEL.
- △ DATUMS AND BASIC DIMENSIONS ESTABLISHED BY CUSTOMER.
- △ POSITION TOLERANCE APPLIES AT CONTACT TIP.
- △ BOARDLOCKS WILL ACCEPT .062 MAX PRINTED CIRCUIT BOARD THICKNESS.
- 7. COMPATIBLE WITH TYPICAL HIGH TEMPERATURE SOLDERING APPLICATIONS TO A MAXIMUM OF 225° C FOR A MAXIMUM DURATION OF 90 SECONDS. TEMPERATURE TO BE MEASURED ON CONNECTOR SURFACE.

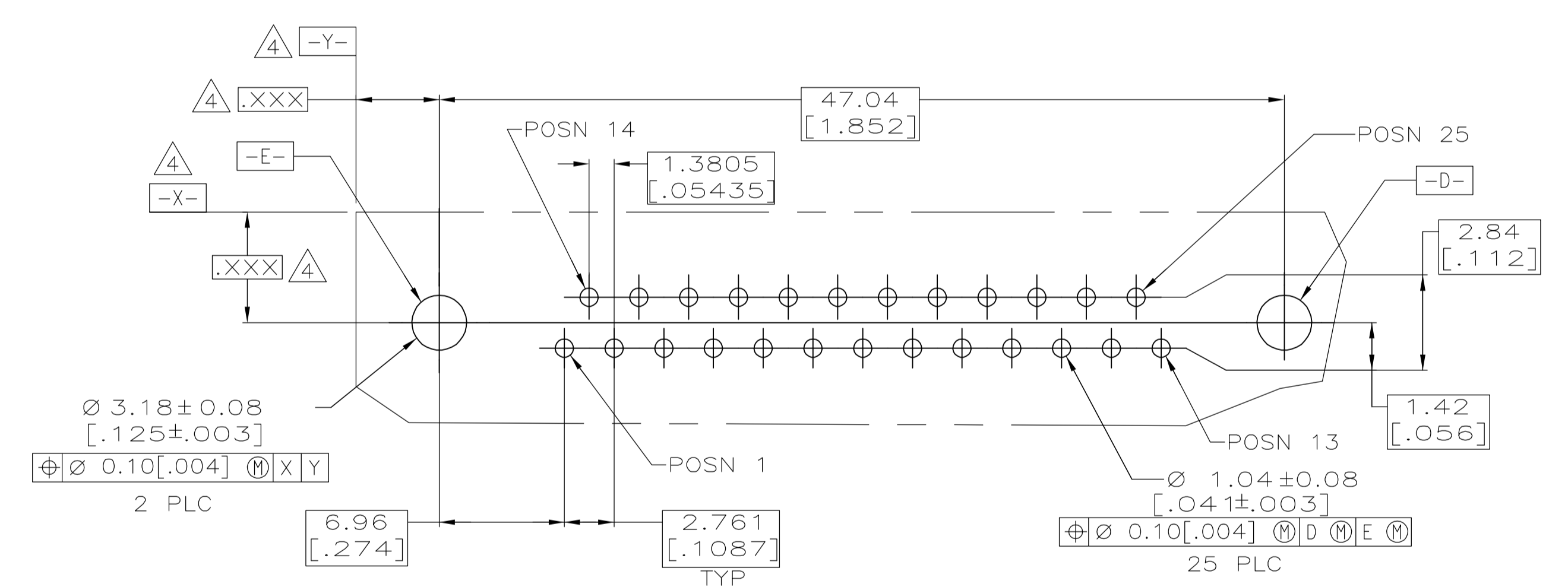

RECOMMENDED PC BOARD LAYOUT
 1.57 [.062] PC BOARD THICKNESS

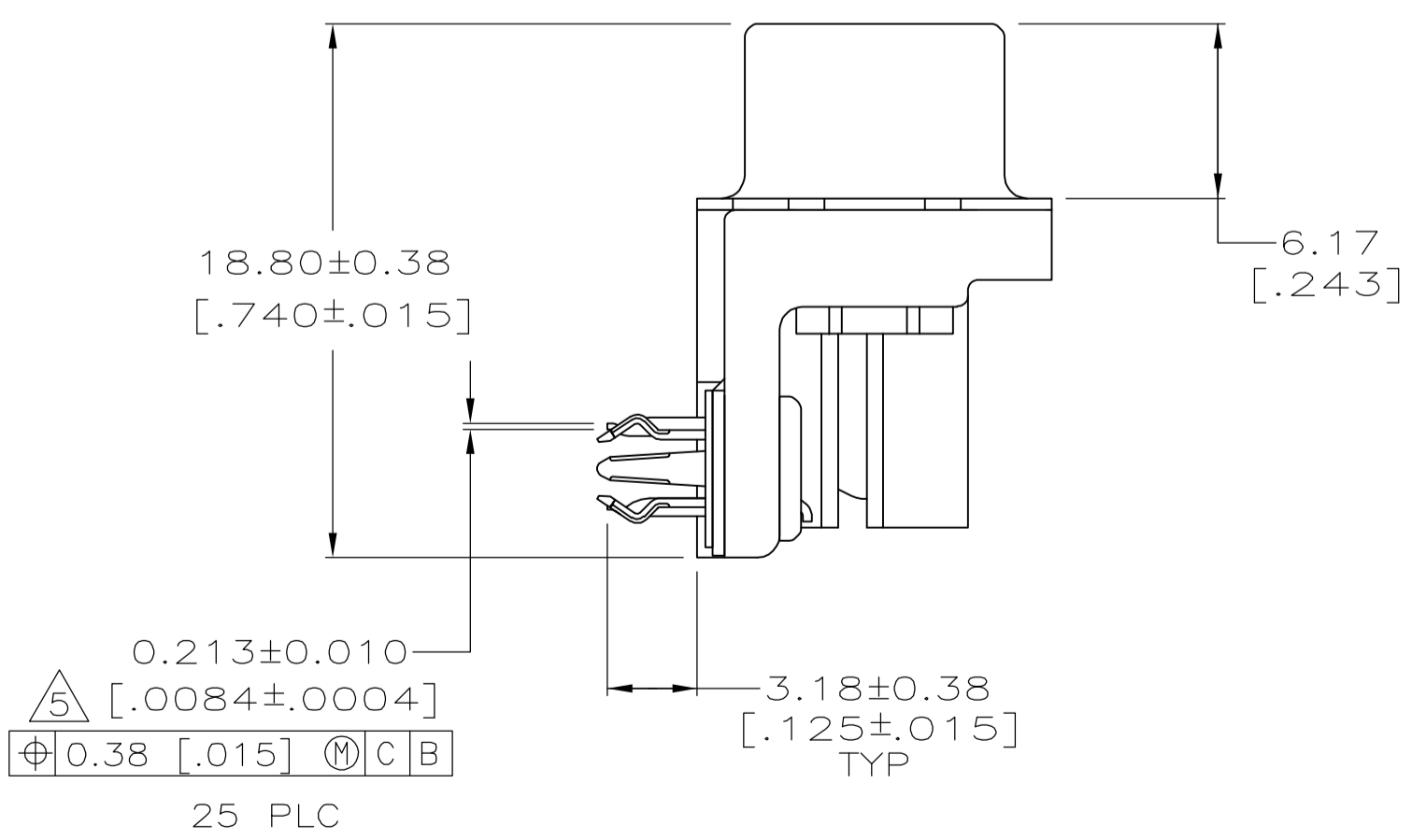

△	5788800-2
△	5788800-1
FINISH	PART NO

THIS DRAWING IS A CONTROLLED DOCUMENT.		DIN J. ALCORTA - DOCK5 04-13-05	Tyco Electronics Corporation Harrisburg, PA 17105-3608
DIMENSIONS: mm [INCHES]		CHK S. BOLASH 04-11-05	
TOLERANCES UNLESS OTHERWISE SPECIFIED:		APVD M. WALMSLEY 04-11-05	RCPT ASSEMBLY, SIZE 3, 318 SERIES, WITH FRONT METAL SHELL, HIGH TEMPERATURE, AMPLIMITE HD-20
0 PLC ± -		NAME	
1 PLC ± -		PRODUCT SPEC	108-40025
2 PLC ± 0.13 [.005]		APPLICATION SPEC	114-40010
3 PLC ± -		SIZE	A1
4 PLC ± -		WEIGHT	00779
ANGLES ± -		CAGE CODE	5788800
FINISH		DRAWING NO	5788800
SEE TABLE		CUSTOMER DRAWING	SCALE 4:1 SHEET 1 OF 1 REV 0

**COPYRIGHT 2005
 TYCO ELECTRONICS CORP
 ALL RIGHTS RESERVED**