

LOC		DIST		REVISIONS			
GP	00	REV	DATE	BY	APP'D		
A	REL PER EC 0513-0043-05		03OCT05	BL	JG		

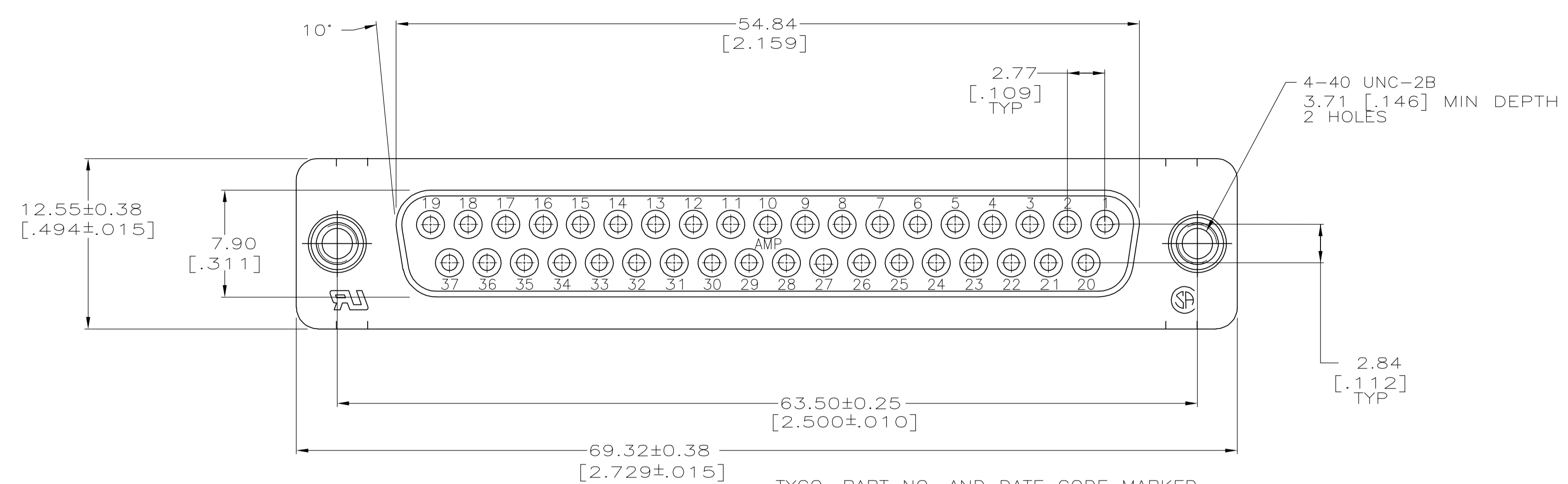

- 1 HOUSING: POLYESTER, UL 94V-0 RATED, COLOR BLACK.
CONTACTS: PHOSPHOR BRONZE.
RETENTION SCREWLOCKS: BRASS.
SHELL: CARBON STEEL.
- 2 SHELL: 5.08µm[.000200] MIN TIN OVER 2.54µm[.000100] MIN COPPER.
CONTACTS: 0.76µm[.000030] MIN GOLD FOR A LENGTH OF 1.40 [.055] MIN FROM MATING END, 2.54µm[.000100] MIN TIN ON OPPOSITE END, BOTH OVER 1.27µm[.000030] MIN NICKEL OVER COPPER FLASH.
RETENTION SCREWLOCKS: 2.54µm[.000100] MIN TIN OVER 1.27µm[.000050] MIN NICKEL OVER COPPER FLASH.
- 3 DATUMS AND BASIC DIMENSIONS ESTABLISHED BY CUSTOMER.
- 4 2.79[.110] MAX IN SHELL TAB CLINCH AREAS.

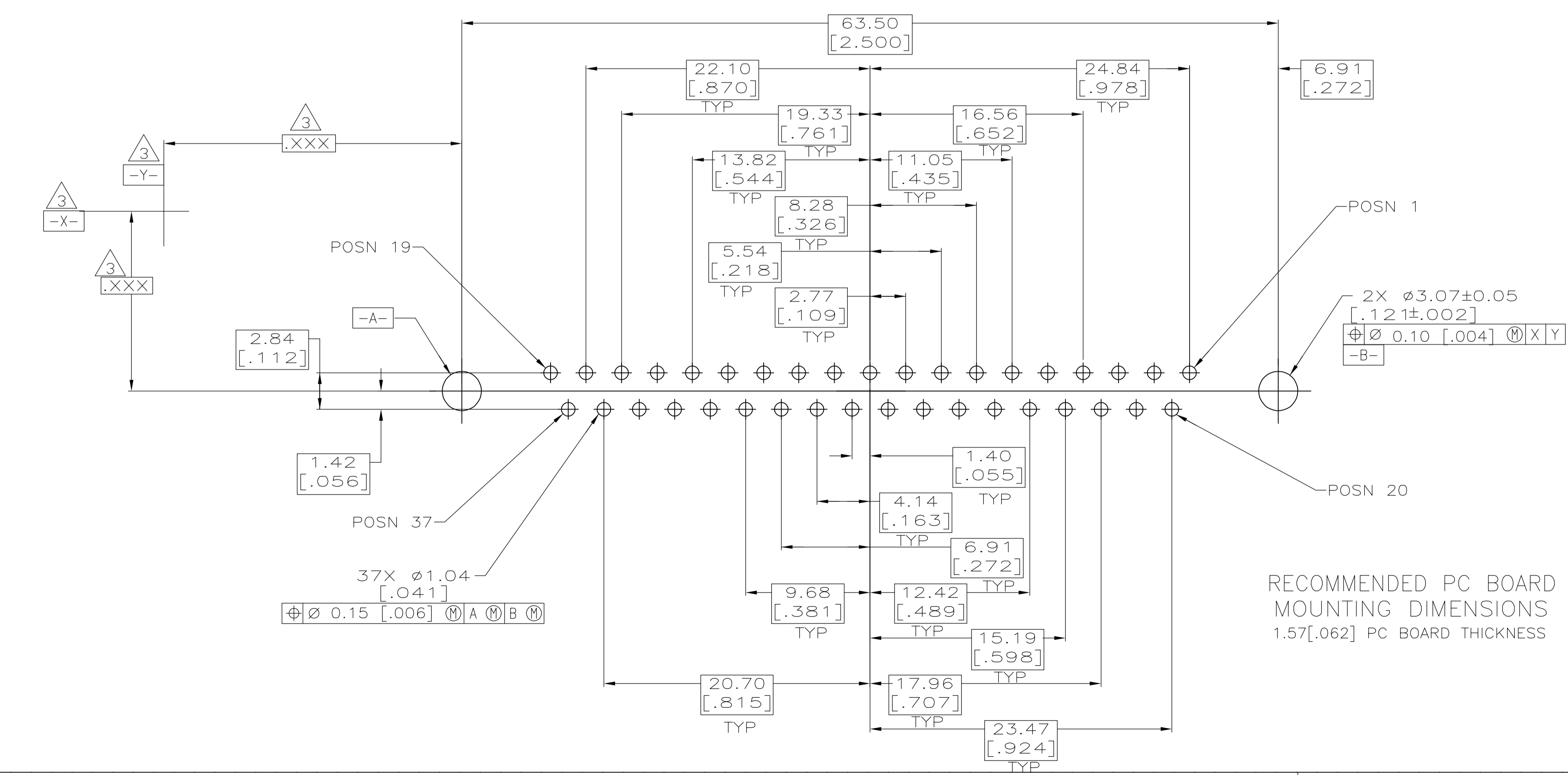
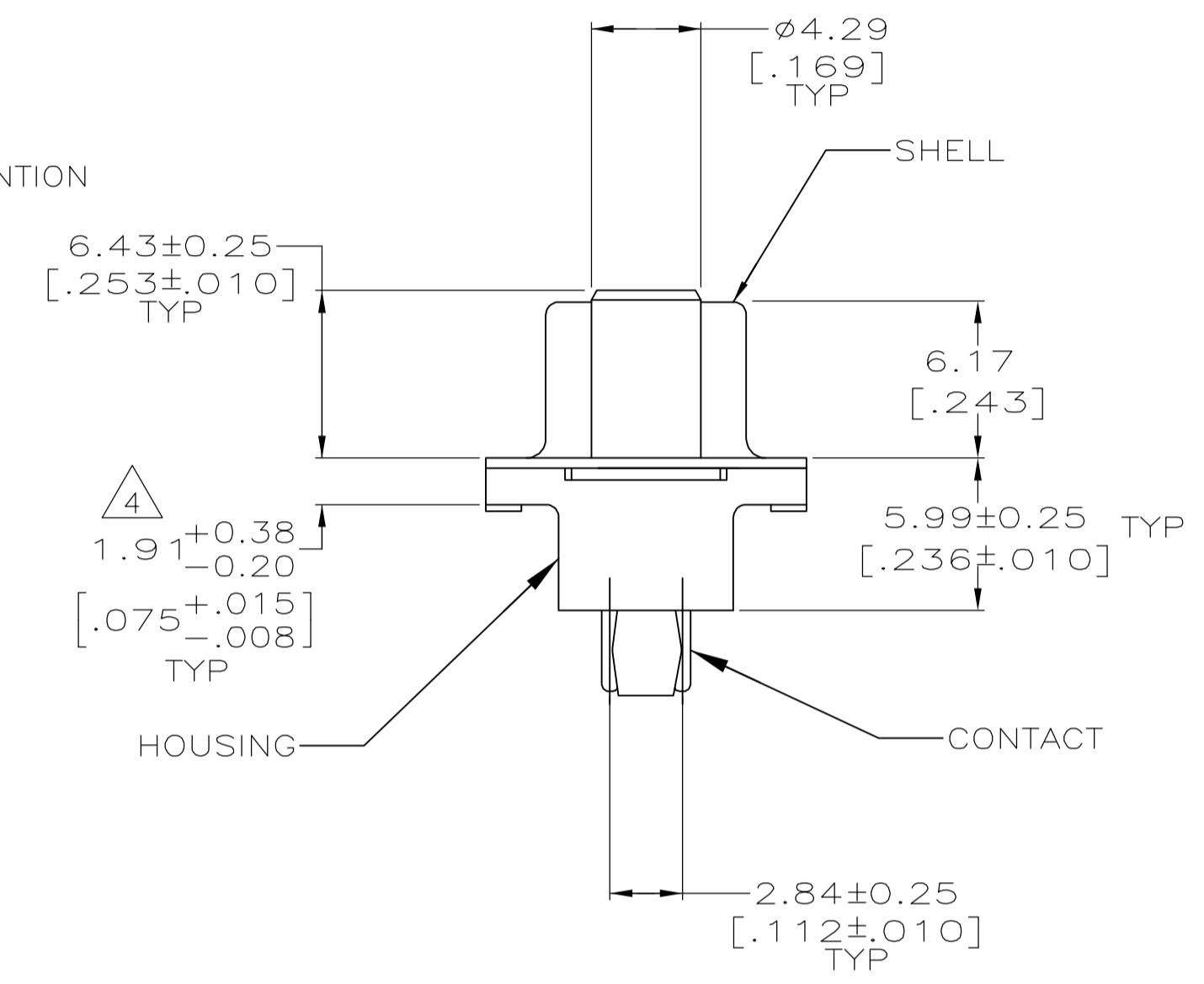
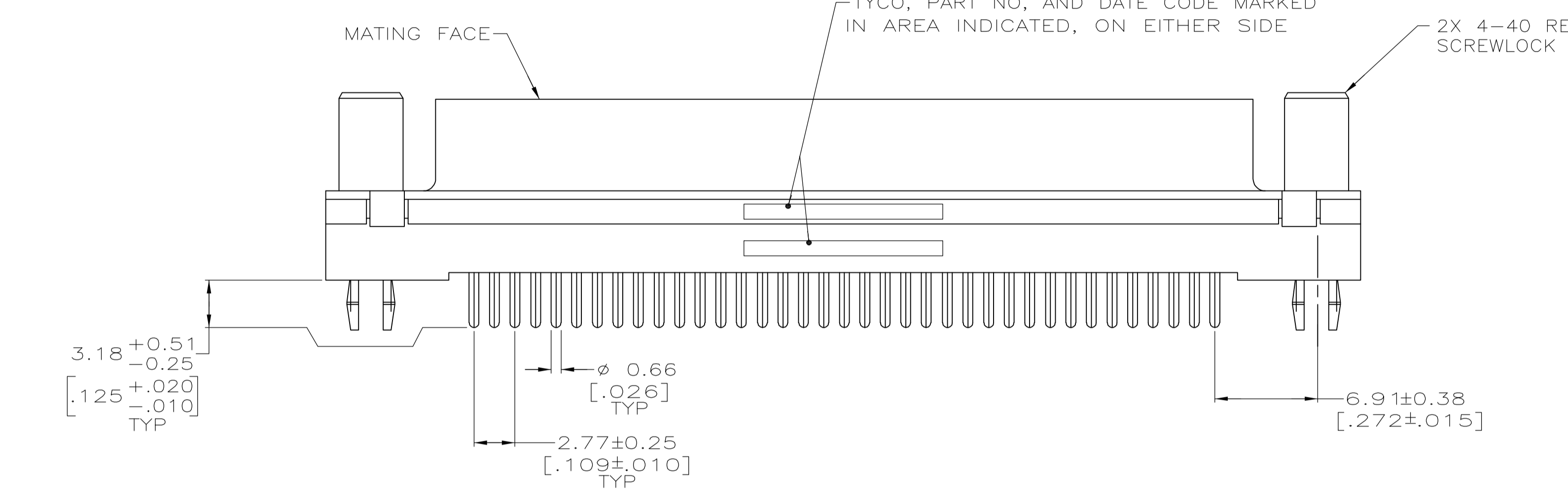

RECOMMENDED PC BOARD MOUNTING DIMENSIONS
 1.57[.062] PC BOARD THICKNESS

5787685-1
 PART NUMBER

THIS DRAWING IS A CONTROLLED DOCUMENT.		DWG: B. LATTUCA	03OCT05		Tyco Electronics Corporation Harrisburg, PA 17105-3608	
DIMENSIONS: mm [INCHES]		CHK: S. BOLASH	03OCT05		NAME: RECEPTACLE ASSEMBLY, SIZE 4, 37 POSITION, FRONT METAL SHELL, RETENTION SCREWLOCKS, AMPLIMITE HD-20	
TOLERANCES UNLESS OTHERWISE SPECIFIED:		APD: M. WALMSLEY		PRODUCT SPEC:	108-40025	
0 PLC ± -		APPLICATION SPEC:		114-40023		
1 PLC ± -		SIZE: A1		CAGE CODE:	00779	
2 PLC ± 0.13 [0.005]		DRAWING NO:		5787685		
3 PLC ± -		WEIGHT:		-		
4 PLC ± -		CUSTOMER DRAWING:		SCALE: 4:1 SHEET 1 OF 1 REV A		
ANGLES ± -						