

REV.	CON. NO.	DATE	DRW.	DESCRIPTION

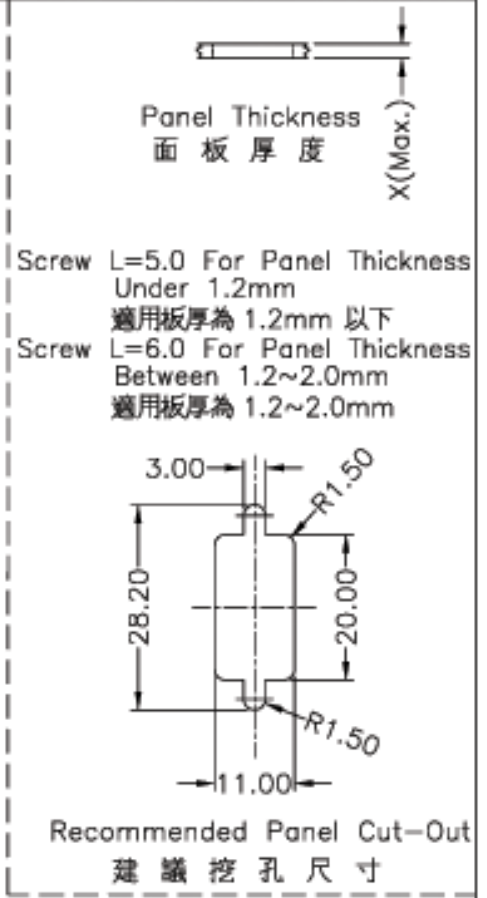

- Note:
- * \varnothing Important Dimension. (\varnothing 為重點尺寸)
 - * Waterproof Rate : IP67
 - * Connector: Black, Nylon+GF
 - * Pin: Copper Alloy, Gold Plated
 - * Do Mating Test After Glued 點膠後, 須作對插測試
 - * Applicable Wire Range: 22AWG-26AWG 適用電線範圍: 22AWG-26AWG
 - * 注意 LOGO 為 ④

UNIT:mm		TITLE	D-SUB,D-SUB,DB-09PMMS	
TOLERANCE		SCALE	Free	SHEET 1 OF 1
JX ± 0.25		REV.	01	SIZE A4
JXX ± 0.1		\varnothing : Inspection Item		
JXXX ± 0.05				
ANGLES $\pm 1'$				

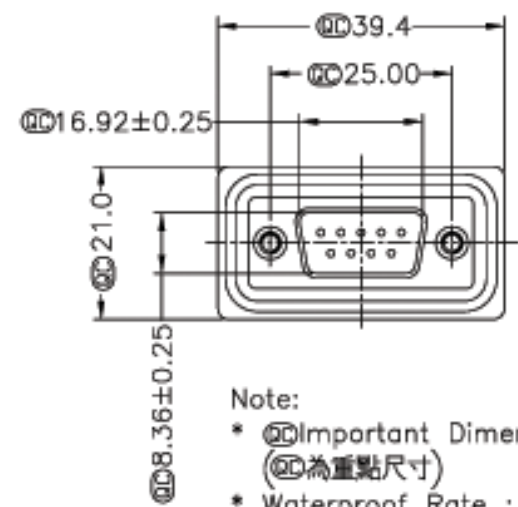
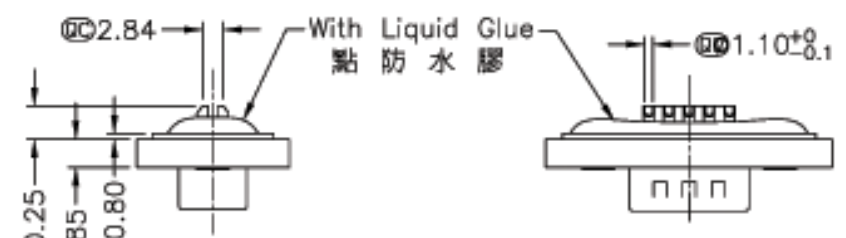
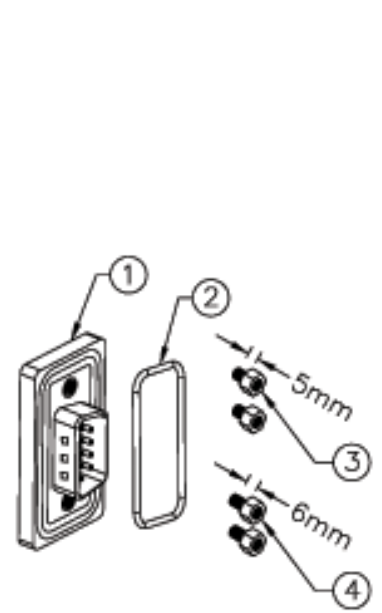

ITEM NO	A-DS-09-LL-WP-R	DRAWN BY	Gao Ling	DATE	2006/05/05
DWG NO	A-DS-09-LL-WP-R	CHECKED BY	Robert Hsu	DATE	2006/05/24
		APPROVED BY	Martin	DATE	2006/05/25