

PC card drilling dimensions (after plating)  
(thickness 1.60 ± 0.20mm)

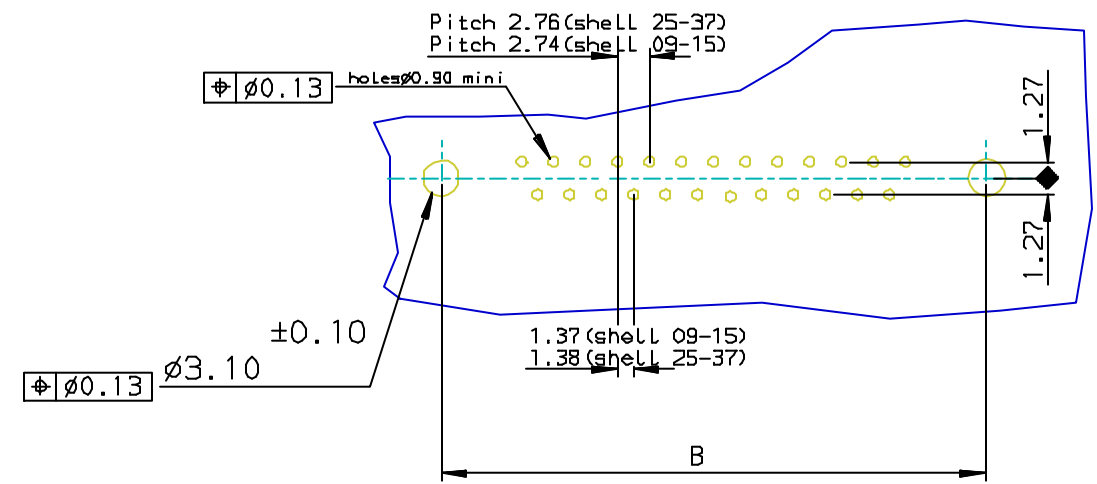

Part Number & Date Code Printing

LF FOR LEAD FREE

SHELL	A ± 0.38	B ± 0.12	C ± 0.10	D ± 0.25	PART NUMBER	PART NUMBER
09	30.81	24.99	16.96	16.21	D09S13F6GL00**	D09S13F6GX00**
15	39.14	33.32	25.18	24.54	D15S13F6GL00**	D15S13F6GX00**
25	53.03	47.04	39.12	38.25	D25S13F6GL00**	D25S13F6GX00**
37	69.32	63.50	55.68	54.71	D37S13F6GL00**	D37S13F6GX00**

Threaded M3

Threaded UNC 4.40

Part number SEE TABLE

**REQUIREMENTS**

**Technical characteristics:**

Shell: steel tin/Zinc Cr3 plated  
 Insulators: self-extinguishing thermoplastic, UL class 94V0  
 Contacts size 20: brass, gold 0.76µ on mating end, bright tin on termination end over nickel on entire contact  
 Cycles < 500

**Harpoons: brass, tin plated**

Metal plate for electrical continuity: brass, tin /Zinc Cr3 plated

Nuts: brass, tin/Zinc Cr3 plated

**Electrical characteristics:**

max. current rating: 5A  
 Test voltage: 1000V  
 Rated voltage: 300V  
 Contact resistance: < 15mΩ  
 Shell resistance: < 5mΩ  
 Insulation resistance: > 5000MΩ

**Climatic characteristics:**

Operating temperature range: -55°C +125°C

**Dimensions:**

In accordance with MIL-C-24308

FOR ROHS DETAILS REFER DWG.NO: C01-8646-0000

European Views

www.fciconnect.com		surface ISO 1302 ✓	tolerance std ISO 406 ISO 1101	projection mm
TOLERANCES UNLESS OTHERWISE SPECIFIED				
Dr	JOHN SLEEBA	1994/07/04	ANGULAR	0.X ± 0.1
Eng	GEORGE VJ	1994/07/04	LINEAR	0.XX ± 0.1
Chr	GEORGE VJ	2005/07/27	0.XX* ± 1*	0.XXX ± 0.1
Appr	KVSD	2005/07/27	Product family	D-SUB
title				size A3
SOCKET CONNECT.DELTA D right angle				Scale 1:1
with nut, harpoon, metal plate				ECN -
catalog no DELTA-D				Spec ref -
FCi			Rev. E	
title			Rev. E	
SOCKET CONNECT.DELTA D right angle			Rev. E	
with nut, harpoon, metal plate			Rev. E	
catalog no DELTA-D			Rev. E	
dwg no C01-8646-0265			Rev. E	
CUSTOMER			Rev. E	
sheet 1 of 1			Rev. E	

rev	ecn no	dr	date
D	105-0124	JS	2005/07/27
E	106-0074	SK	2006/06/08
-	-	-	-
-	-	-	-
-	-	-	-
-	-	-	-



Copyright FCI.