

|              |            |   |   |   |   |   |   |   |   |
|--------------|------------|---|---|---|---|---|---|---|---|
| 10           | 9          | 8 | 7 | 6 | 5 | 4 | 3 | 2 | 1 |
| MATERIAL NO. | ENG. NO.   |   |   |   |   |   |   |   |   |
| 836119006    | 83611-9006 |   |   |   |   |   |   |   |   |

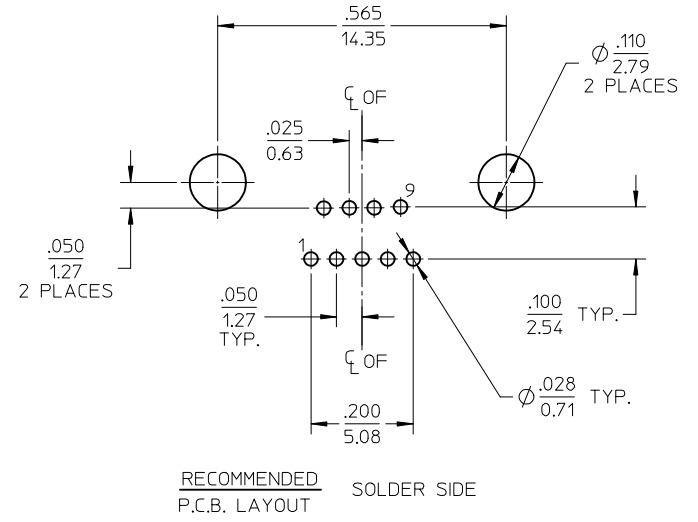
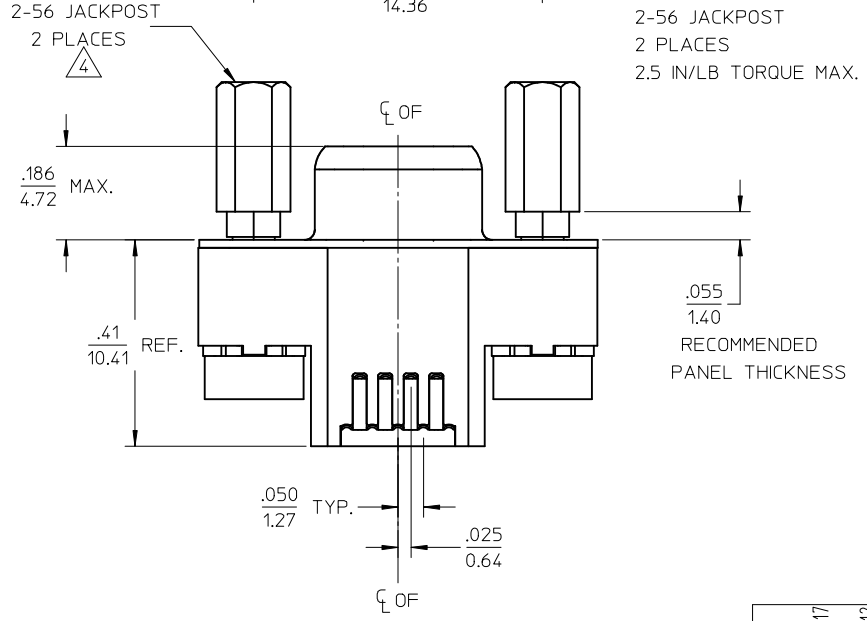
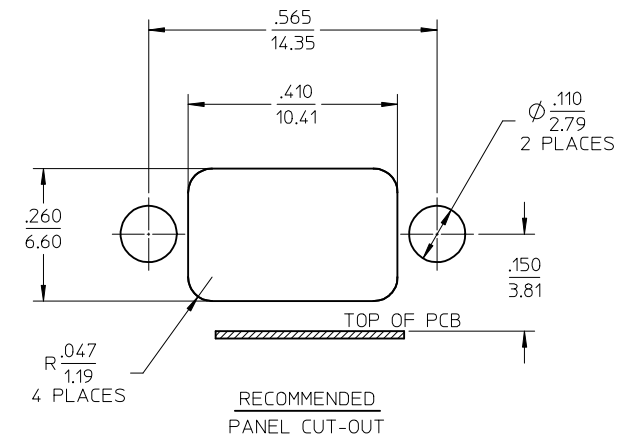
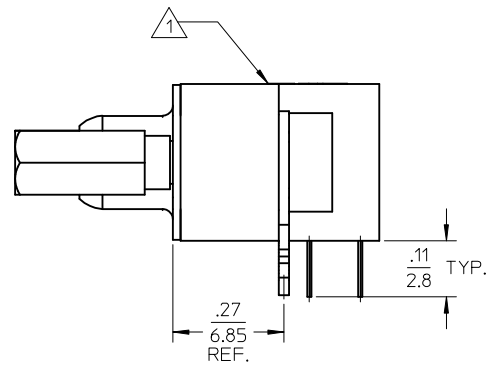
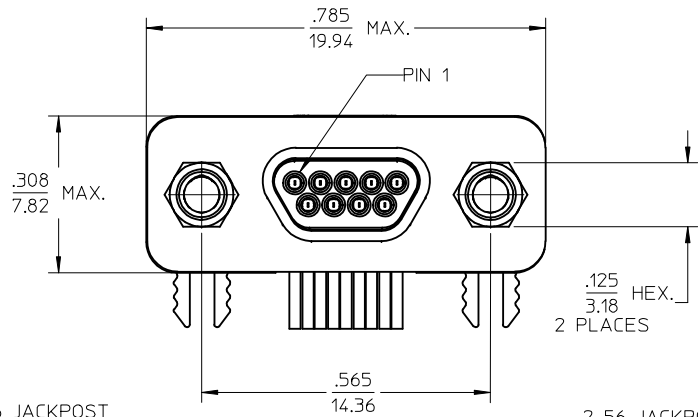

- NOTES:
- DATE CODE : 08(YR)XX(WEEK)C(CHINA)
  - SEE PS-83421-9000
  - ROHS COMPLIANT.
  - 2.5 IN/LB TORQUE MAX.

| <b>REDRAWN</b><br>EC NO: WNA2008-0145<br>DR: WNRUPERT 2008/10/17<br>CHKD:<br>APPR: JF MURPHY 2008/11/12<br>REV | QUALITY SYMBOLS | GENERAL TOLERANCES (UNLESS SPECIFIED)<br><table border="1"> <tr> <th></th> <th>mm</th> <th>INCH</th> </tr> <tr> <td>4 PLACES</td> <td>± ---</td> <td>± ---</td> </tr> <tr> <td>3 PLACES</td> <td>± ---</td> <td>± .005</td> </tr> <tr> <td>2 PLACES</td> <td>± 0.13</td> <td>± .010</td> </tr> <tr> <td>1 PLACE</td> <td>± 0.25</td> <td>± ---</td> </tr> </table> ANGULAR ± 1° |              | mm           | INCH  | 4 PLACES | ± --- | ± --- | 3 PLACES | ± --- | ± .005 | 2 PLACES | ± 0.13 | ± .010 | 1 PLACE | ± 0.25 | ± --- | DIMENSION STYLE | SCALE | DESIGN UNITS | THIRD ANGLE PROJECTION |
|--|-----------------|---|--------------|--------------|---|----------|-------|-------|----------|-------|--------|----------|--------|--------|---------|--------|-------|-----------------|-------|--------------|------------------------|
|  |                 |   | mm           | INCH         |   |          |       |       |          |       |        |          |        |        |         |        |       |                 |       |              |                        |
|  | 4 PLACES        |   | ± ---        | ± ---        |   |          |       |       |          |       |        |          |        |        |         |        |       |                 |       |              |                        |
|  | 3 PLACES        |   | ± ---        | ± .005       |   |          |       |       |          |       |        |          |        |        |         |        |       |                 |       |              |                        |
| 2 PLACES   | ± 0.13          | ± .010  |              |              |   |          |       |       |          |       |        |          |        |        |         |        |       |                 |       |              |                        |
| 1 PLACE  | ± 0.25          | ± ---   |              |              |   |          |       |       |          |       |        |          |        |        |         |        |       |                 |       |              |                        |
|  |                 | IN/MM   | 4:1          | INCH         |   |          |       |       |          |       |        |          |        |        |         |        |       |                 |       |              |                        |
|  |                 |   | DRAWN BY     | DATE         | TITLE   |          |       |       |          |       |        |          |        |        |         |        |       |                 |       |              |                        |
|  |                 |   | JLOMASTR     | 04/09/21     | CONNEX, COMMERCIAL-D, PLUG RT ANGLE, JKPOST, SIZE 9   |          |       |       |          |       |        |          |        |        |         |        |       |                 |       |              |                        |
|  |                 |   | CHECKED BY   | DATE         |   |          |       |       |          |       |        |          |        |        |         |        |       |                 |       |              |                        |
|  |                 |   | RDEROSS      | 04/09/28     |   |          |       |       |          |       |        |          |        |        |         |        |       |                 |       |              |                        |
|  |                 |   | APPROVED BY  | DATE         |   |          |       |       |          |       |        |          |        |        |         |        |       |                 |       |              |                        |
|  |                 |   | RDEROSS      | 04/09/28     |   |          |       |       |          |       |        |          |        |        |         |        |       |                 |       |              |                        |
|  |                 |   | MATERIAL NO. | DOCUMENT NO. |   |          |       |       |          |       |        |          |        |        |         |        |       |                 |       |              |                        |
|  |                 |   | SEE CHART    |              | MOLEX INCORPORATED  |          |       |       |          |       |        |          |        |        |         |        |       |                 |       |              |                        |
|  |                 |   |              |              | SD-83611-001  |          |       |       |          |       |        |          |        |        |         |        |       |                 |       |              |                        |
|  |                 |   |              |              | SHEET NO. 1 OF 1  |          |       |       |          |       |        |          |        |        |         |        |       |                 |       |              |                        |
|  |                 |   |              |              | THIS DRAWING CONTAINS INFORMATION THAT IS PROPRIETARY TO MOLEX INCORPORATED AND SHOULD NOT BE USED WITHOUT WRITTEN PERMISSION |          |       |       |          |       |        |          |        |        |         |        |       |                 |       |              |                        |