

DRAWING MADE IN AMERICAN PRODUCTION

© 1969 BY AMP INCORPORATED. ALL RIGHTS RESERVED. AMP PRODUCTS COVERED BY PATENTS AND/OR PATENT PENDING.

ALL DIMENSIONS ARE IN INCHES UNLESS OTHERWISE SPECIFIED. DIMENSIONS ARE TO BE TAKEN TO THE CENTER OF THE WIRE UNLESS OTHERWISE SPECIFIED.

REVISIONS				
ZONE	LTR	DESCRIPTION	DATE	APPROVED
	E	MAT'L WAS B-10	11/11/72	Ken K
	F	REVISED NOTE 1	10-15-73	JPA
	G	REVISED PER ECN 4349	5-22-74	D.S.
	H	REV PER ECN 5-3960	9/16/87	RS
	J	OBS. 830177-2 ECN DF-0694 mc	9/13/88	J.W.

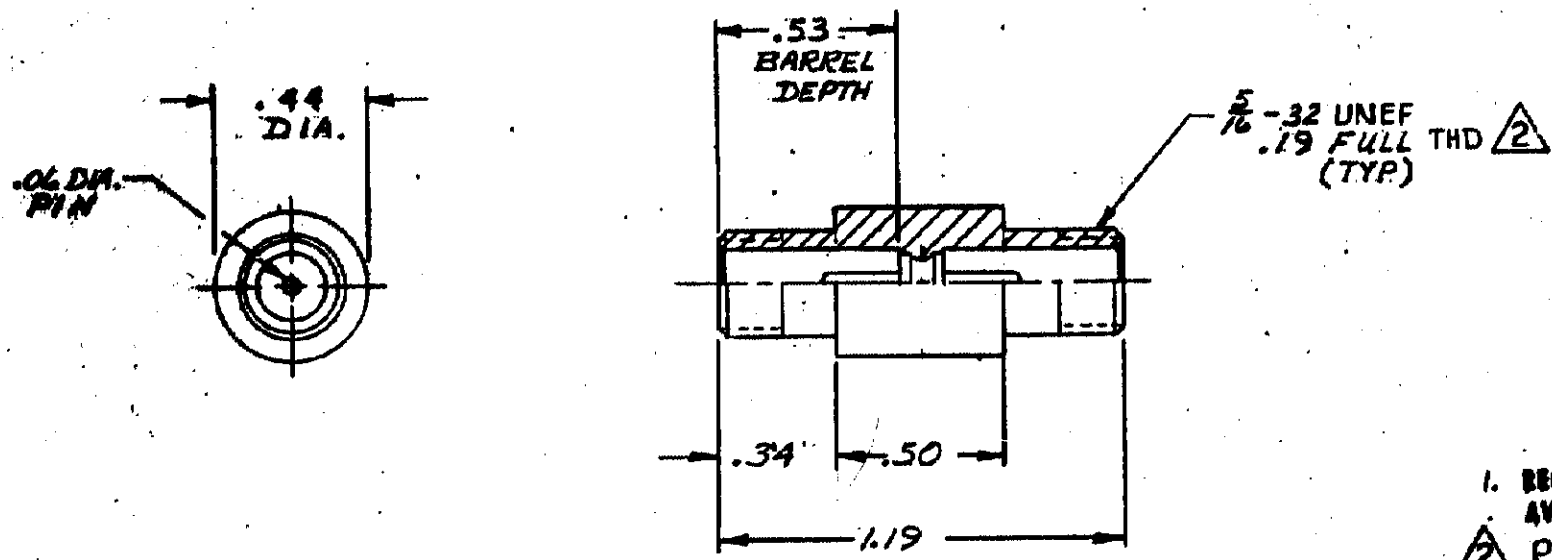

1. RECEPTACLE TO MATE WITH AMP LGN-1/2 LEAD ASSEMBLY. AVAILABLE SEPARATELY.
 2. PER FEDERAL STANDARD H-28 3 WIRE METHOD. DIMENSION OVER WIRES TO BE: .307-.315.

OBS	830177-2	AS SHOWN EXCEPT CONTACT (GOLD PLATED)
	830177-1	AS SHOWN EXCEPT CONTACT (TIN PLATED)

QTY REQD	QTY REQD	ITEM NO.	DWG SIZE	PART OR IDENTIFYING NO.	NOMENCLATURE OR DESCRIPTION	SYMBOL
-2	-1					

UNLESS OTHERWISE SPECIFIED DIMENSIONS ARE IN INCHES TOLERANCES .10-.24 ANGLES .000-.015				CONTRACT NO. OR <i>4-16-69</i>		AMP INCORPORATED CAPTRON DIVISION ELIZABETHTOWN, PENNSYLVANIA	
MATERIAL: MOLDED GLASS EPOXY				CHK <i>J.P. Johnson</i>		NAME RECEPTACLE, FEED-THRU FOR SPLICE APPLICATION LGN-1/2	
FINISH: BLACK				DESIGN APPD		SIZE B	CODE IDENT NO. 00779
NEXT ASSY				OTHER APPD		NUMBER 830177	SHEET 1 OF 1
NEXT ASSY				APPLICATION			

CUSTOMER DRAWING