

DRAWING MADE IN AMERICAN PROJECTION

© 1973 BY AMP INCORPORATED. ALL RIGHTS RESERVED. AMP PRODUCTS COVERED BY PATENTS AND/OR PATENTS PENDING.

THIS PRODUCT DESIGNED AND BUILT BY AMP INCORPORATED. NO LICENSE TO USE THAT DESIGN IN MANUFACTURE, OR TO USE ANY ISSUED OR PENDING PATENTS WHICH ARE INVOLVED, IS IMPLIED.

| REVISIONS |     |                          |            |             |
|-----------|-----|--------------------------|------------|-------------|
| ZONE      | LTR | DESCRIPTION              | DATE       | APPROVED    |
|           | D   | REV. / REDRAWN           | DLA 2-9-73 | [Signature] |
|           | E   | UP-DATED ECN 8333 R.G.R. | 6/1/78     | [Signature] |
|           | F   | REV PER ECN S-3960       | 9-10-87    | R8          |

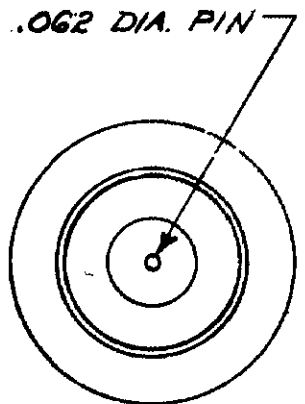
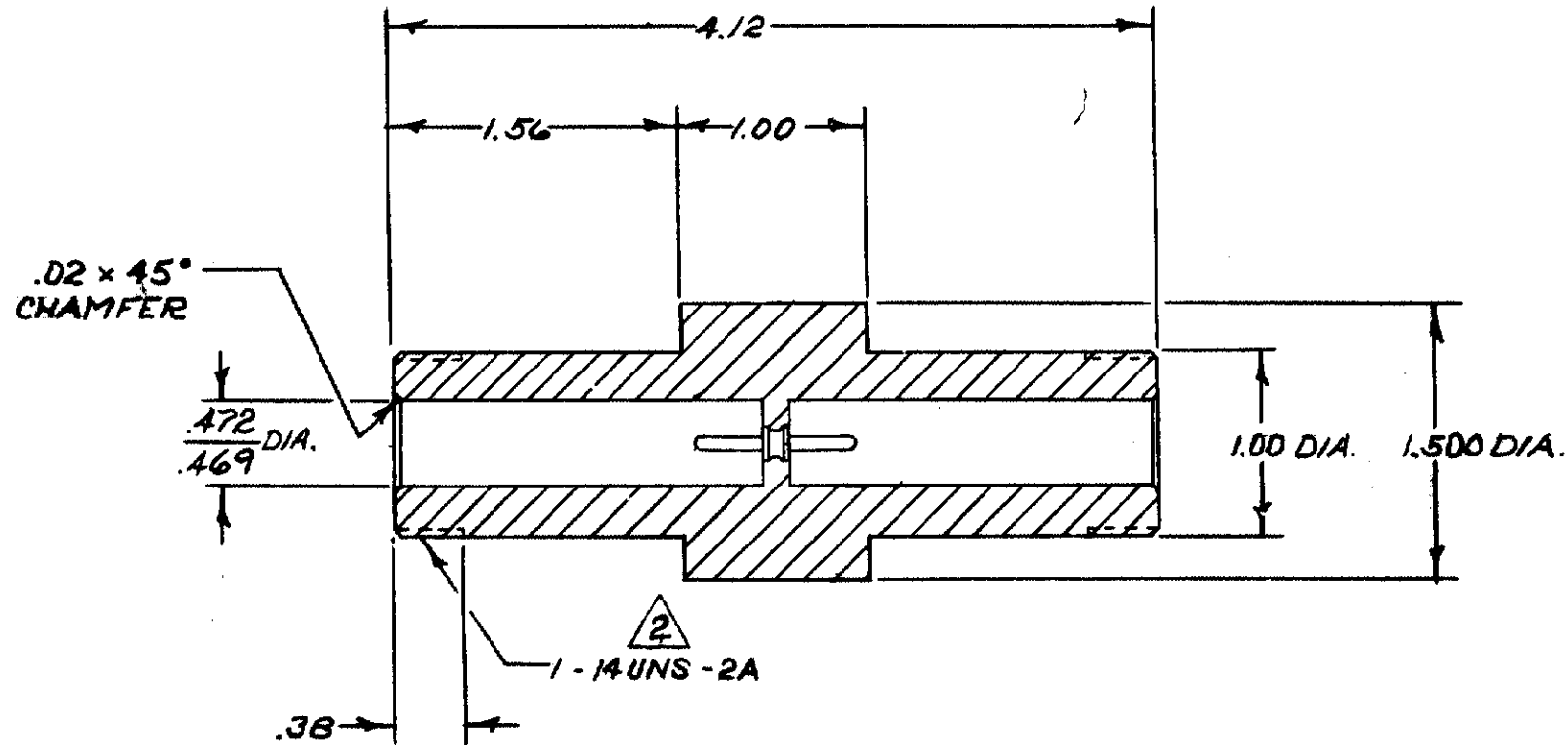

1. RECEPTACLE TO MATE WITH AMP LGH-4 LEAD ASSEMBLY. AVAILABLE SEPARATELY.

2. PER FEDERAL STANDARD H-28 3 WIRE METHOD, DIMENSION OVER WIRES TO BE: .9975-1.0186.

|          |  |
|----------|--|
| 840467-2 | AS SHOWN; WITH GOLD PLATED PIN PER MIL-G45624 TYPE II, CLASS 3         |
| 840467-1 | AS SHOWN; WITH TIN PLATED PIN PER MIL-T-10727 TYPE I OR II, .0001 THK. |

| QTY REQD | QTY REQD | ITEM NO. | DWG SIZE | PART OR IDENTIFYING NO. | NOMENCLATURE OR DESCRIPTION | SYMBOL |
|----------|----------|----------|----------|-------------------------|-----------------------------|--------|
| -2       | -1       |          |          |                         |                             |        |

|           |            |              |         |  |                                  |   |  |
|-----------|------------|--------------|---------|--|----------------------------------|---|--|
|           |            |              |         | UNLESS OTHERWISE SPECIFIED:<br>DIMENSIONS ARE IN INCHES<br>TOLERANCES<br>.00 = ± .015 ANGLES = .000 = ± .005 | CONTRACT NO.<br>DR C. E. DORWART | <br>AMP INCORPORATED<br>CAPITRON DIVISION,<br>ELIZABETHTOWN, PENNSYLVANIA |  |
|           |            |              |         | MATERIAL:<br>MOLDED GLASS<br>EPOXY   | CHK                              |   | NAME<br>CONNECTOR, FEED-THRU ASS'Y.<br>FOR SPLICE APPLICATIONS LGH-4 |
|           |            |              |         | FINISH:<br>BLACK   | APPD J.W. GAW                    | SIZE B  |  |
|           |            |              |         |  | APPD                             | CODE IDENT NO. 89110  |  |
|           |            |              |         |  | DSGN APPD                        | NUMBER 840467   |  |
|           |            |              |         |  | OTHER APPD                       | SCALE ~ WT SHEET 1 OF 1   |  |
| NEXT ASSY | FINAL ASSY | NEXT ASSY    | USED ON |  |                                  |   |  |
| QTY REQD  |            | APPL. CATION |         |  |                                  |   |  |

PRINT DIST L 137