

© 1973 BY AMP INCORPORATED. ALL RIGHTS RESERVED. AMP PRODUCTS COVERED BY PATENTS AND/OR PATENTS PENDING.

THIS PRODUCT DESIGNED AND BUILT BY AMP INCORPORATED. NO LICENSE TO USE THAT DESIGN IN MANUFACTURE, OR TO USE ANY ISSUED OR PENDING PATENTS WHICH ARE INVOLVED, IS IMPLIED.

Unpublished copy not to be reproduced nor published without written permission of AMP Incorporated

REVISIONS				
ZONE	LTR	DESCRIPTION	DATE	APPROVED
	A	ADDED TIN & GOLD PLATE FLANGES TO -1, & -2	7-13-73	RE Fry
B-2	B	ADDED NOTE -2	1/23/74	M.S
	C	REV -2	2/16/74	RE Fry
	D	ADDED .312 DIA, .875 .020, .22, ECN 8041, D.S.	5-19-75	M.S
	E	REMOVED -2	10-14-76	M.S
	F	REV. <sup>.692</sup> / <sub>.688</sub> WAS .712 DIA.	9/27/78	M.S
	G	REV PER OH14-0192-05	1-06	PY

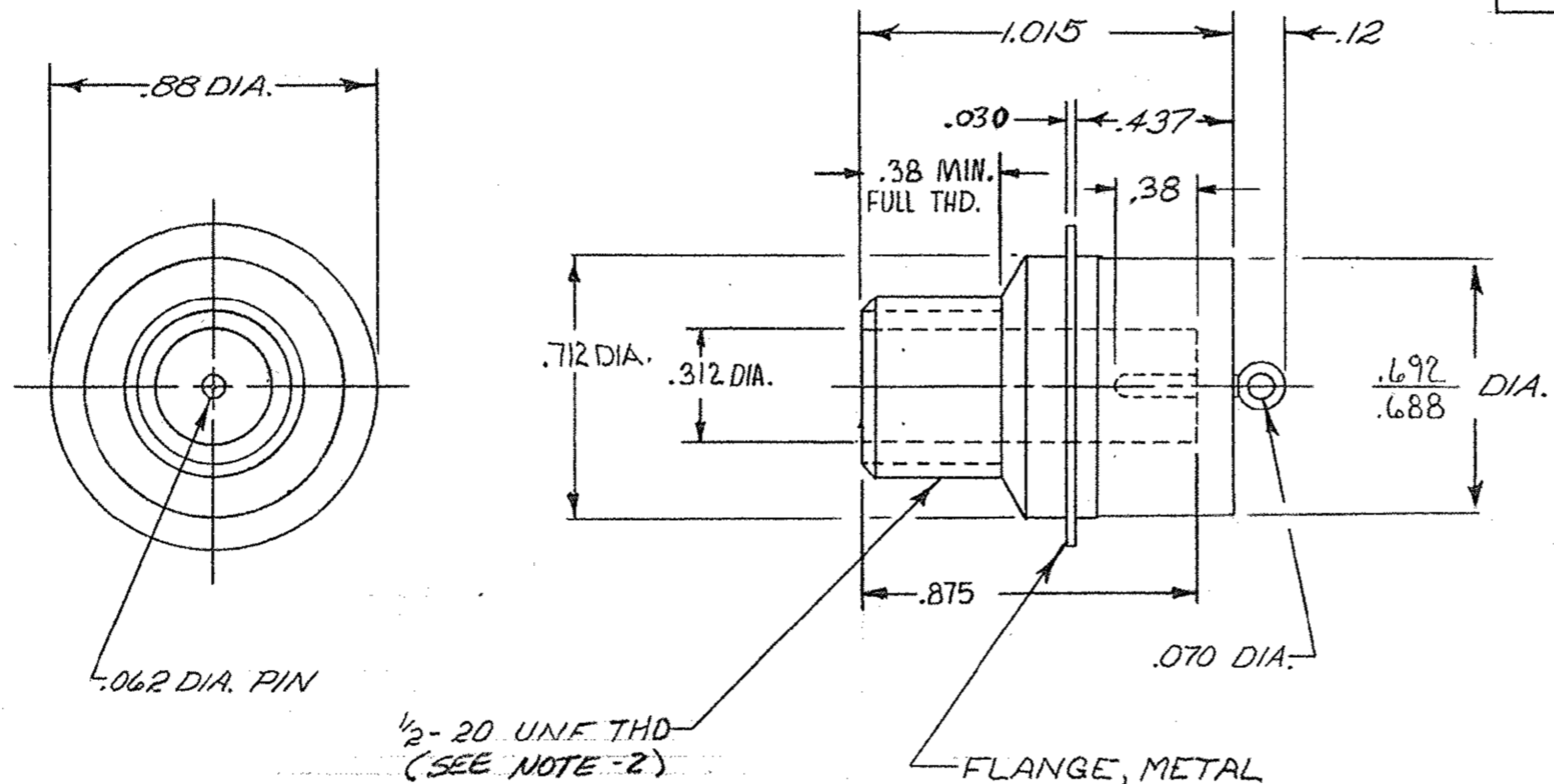

NOTES:  
 1. THIS IS A HERMETICALLY SEALED RECEPTACLE  
 2. SCREW THREAD MEASUREMENT IN ACCORDANCE WITH H2B HANDBOOK. (3 WIRE METHOD). USING WIRE .02887 DIA. MEASUREMENT OVER WIRE SHALL BE  $\frac{.510}{.497}$

5-861254-1	TIN PLATED PIN AND FLANGE	WITH MARKING
861254-1	TIN-LEAD PLATED PIN AND FLANGE	WITH MARKING

QTY REQD	QTY REQD	ITEM NO.	DWG SIZE	PART OR IDENTIFYING NO.	NOMENCLATURE OR DESCRIPTION	SYMBOL
-2	-1					

UNLESS OTHERWISE SPECIFIED: DIMENSIONS ARE IN INCHES TOLERANCES .00 ± .01 ANGLES ± 1° .000 ± .005				CONTRACT NO. DR <i>D. Fry</i> 4-3-73 CHK		AMP INCORPORATED CAPITRON DIVISION ELIZABETHTOWN, PENNSYLVANIA	
MATERIAL: MOLDED GLASS EPOXY				APPD <i>RE Fry</i> 4-4-73 APPD		NAME FLANGED RECEPTACLE ASSEMBLY LQH-1	
FINISH: BLACK				DSGN APPD		SIZE B	CODE IDENT NO. 00779
NEXT ASSY				OTHER APPD		NUMBER 861254	
QTY REQD				SCALE 2:1		WT	SHEET
APPLICATION							

PRINT DIST 37

UPDATED A