

© COPYRIGHT 1973 BY AMP INCORPORATED, HARRISBURG, PA. ALL INTERNATIONAL RIGHTS RESERVED. AMP INCORPORATED PRODUCTS COVERED BY U. S. AND FOREIGN PATENTS AND/OR PATENTS PENDING.

REVISIONS						
P	F	ZONE	LTR	DESCRIPTION	DATE	APPROVED
			A	ADDED .468 DIA., .38, 2.00, ECN 8041, DS	5-19-75	<i>[Signature]</i>
			B	REMOVED -2 WAS GOLD PLATED, DS	5-19-78	<i>[Signature]</i>
			C	REV PER ECN S-3960	4-10-87	RB
			D	REVISED PER 0H14-0192-05	1-06	PY

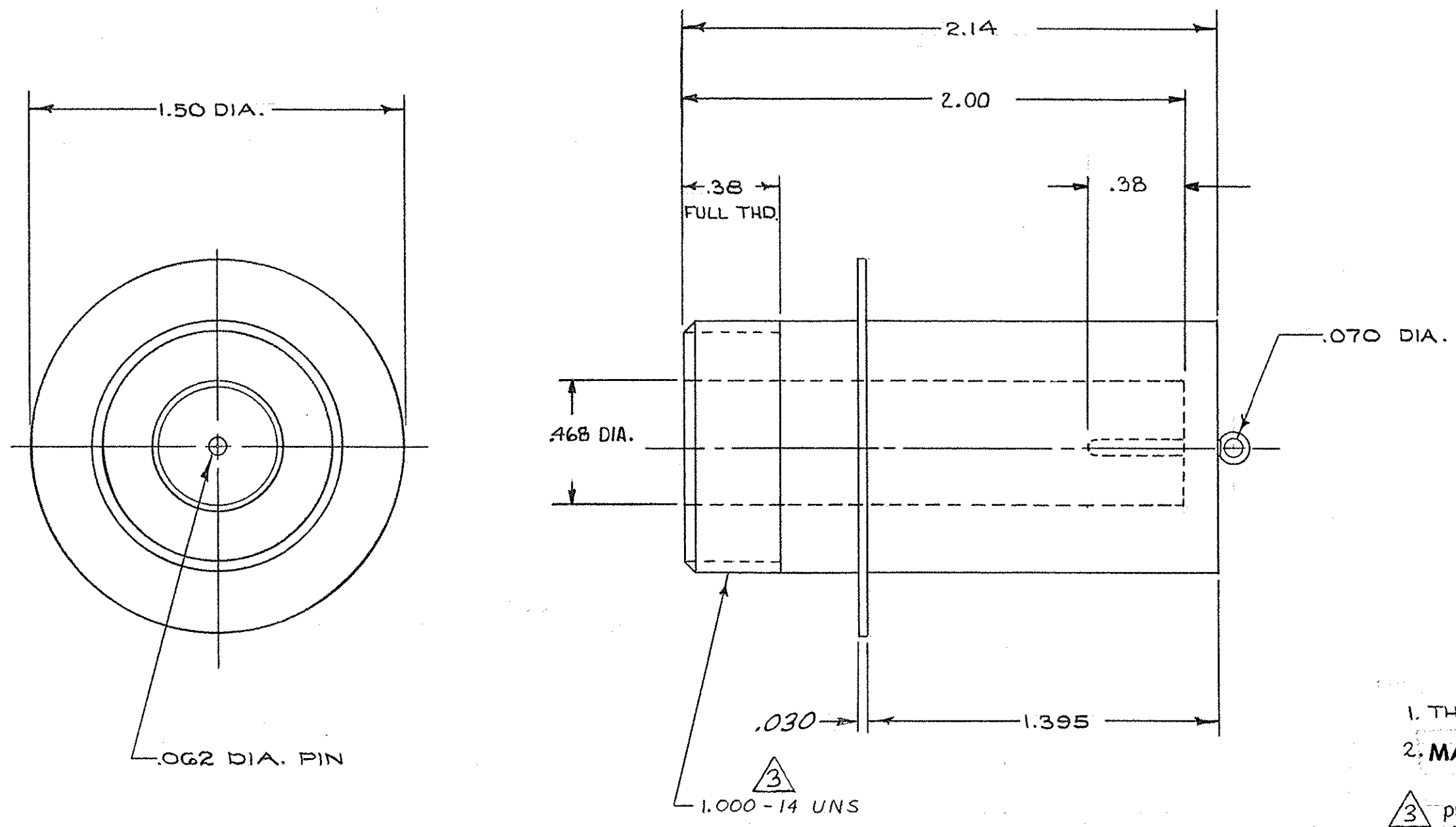

1. THIS RECEPTACLE IS HERMETICALLY SEALED
  2. MARK PER AMP SPEC. 118-36000 (WHITE INK)
- $\Delta$  3 PER FEDERAL STANDARD H-28 3 WIRE METHOD. DIMENSION OVER WIRES TO BE: .9975-1.0186.

AS SHOWN WITH TIN PLATED PIN & FLANGE	5-861258-1
AS SHOWN WITH TIN-LEAD PLATED PIN & FLANGE	861258-1
	PART NO

UNLESS OTHERWISE SPECIFIED DIMENSIONS ARE IN INCHES. TOLERANCES: .00 ± .01 .000 ± .005 ANGLES ±	CONTRACT NO		AMP INCORPORATED Elizabethtown, Pa.								
	DR <i>D. Meyer</i> 7/26/73			NAME RECEPTACLE, FLANGED LGH-4							
	CHK										
	APPD <i>RE Fry</i> 7-31-73 APPD										
MATERIAL MOLDED GLASS EPOXY	DSGN APPD		SIZE <b>C</b>								
FINISH BLACK	OTHER APPD		CODE IDENT NO <b>89110</b>								
<table border="1"> <tr> <th>NEXT ASSY</th> <th>FINAL ASSY</th> <th>NEXT ASSY</th> <th>USED ON</th> </tr> <tr> <td> </td> <td> </td> <td> </td> <td> </td> </tr> </table>	NEXT ASSY	FINAL ASSY	NEXT ASSY	USED ON					QTY REQD      APPLICATION		NUMBER <b>861258</b>
NEXT ASSY	FINAL ASSY	NEXT ASSY	USED ON								
			SCALE 2:1      WT      SHEET 1 OF 1								

UP-DATED