

THIS DRAWING IS UNPUBLISHED. RELEASED FOR PUBLICATION  
 BY AMP INCORPORATED. ALL RIGHTS RESERVED.

LOC	DIST	REVISIONS					
DF	SO	P	LTR	DESCRIPTION	DATE	DWN	APVD
		H		REV PER 0600-2174-94	04-19-95	TT	DE

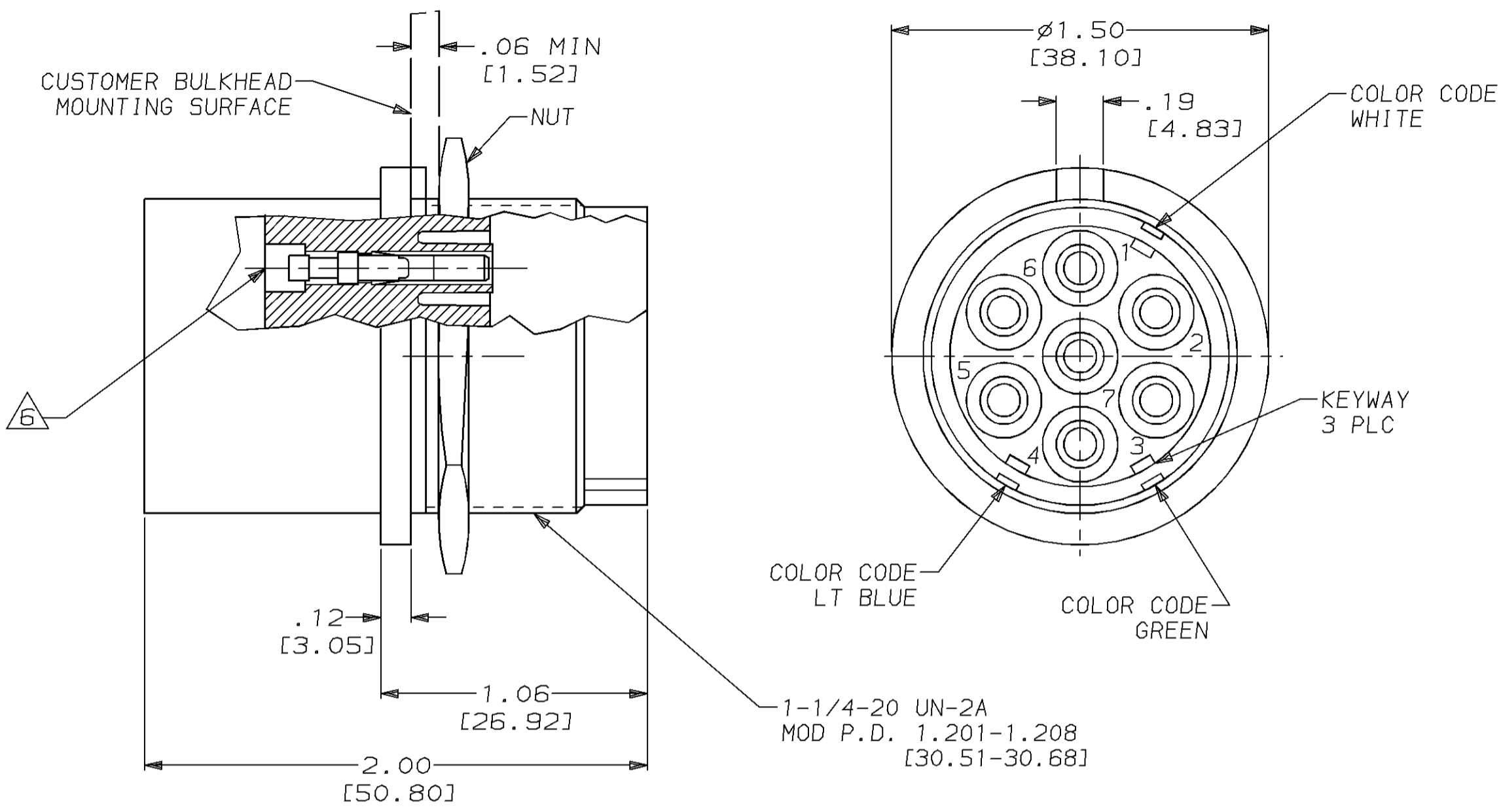

- SEVEN CONTACT CAVITIES ACCEPT TYPE II, SIZE 16 SOCKETS AND COAX CONTACTS AS SHOWN IN TABLE. EXTRACTION TOOL PART NUMBER IS 861751-1.
- TYPE II SOCKETS TO ACCEPT 22 AWG - 24 AWG STRANDED WIRE. SOCKETS GOLD PLATED PER MIL-G-45204 TYPE II .000050 MIN THK.
- RECEPTACLE WILL WITHSTAND WITHOUT BREAKDOWN, 27 KVDC PIN TO PIN & 27 KVDC PIN TO GRD WHEN MATED WITH 861648-1.
- TYPE II SOCKETS TO ACCEPT ONE 16 AWG OR ONE 18 AWG STRANDED WIRE.
- TYPE II SOCKETS TO ACCEPT 14 AWG STRANDED WIRE.
- CUSTOMER TO ATTACH LEADS & PROTECT AGAINST ARC OVER & BREAKDOWN BY POTTING. SOCKETS TO BE COATED WITH RTV108

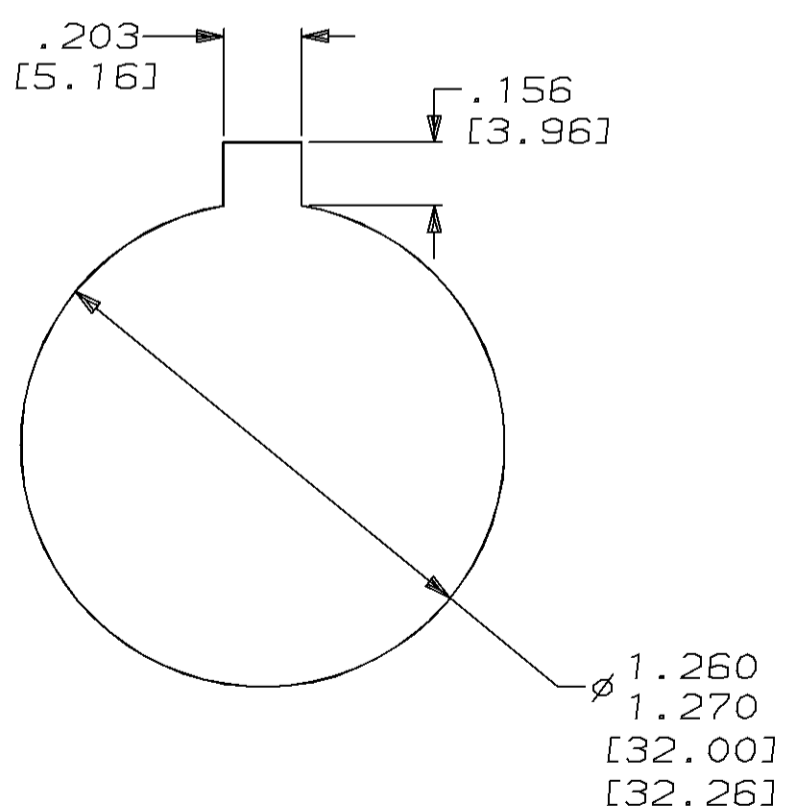

RECOMMENDED PANEL CUTOUT

MARKER	NO	45098	14	861647-9
5	NO	45098	16, 18	861647-8
2	NO	45099	20, 22, 24	861647-7
	YES	NO SOCKETS		861647-6
6	YES	45098	14	861647-5
	YES	5 COAX 69656	20-24 & COAX	861647-4
	YES	1 COAX 69656	20-24 & COAX	861647-3
5	YES	45098	16, 18	861647-2
2	YES	45099	20, 22, 24	861647-1
RMKS	COLOR CODING	HAND TOOL	WIRE SIZE RANGE	PART NUMBER

THIS DRAWING IS A CONTROLLED DOCUMENT FOR AMP INCORPORATED. IT IS SUBJECT TO CHANGE AND THE CONTROLLING ENGINEERING ORGANIZATION SHOULD BE CONTACTED FOR THE LATEST REVISION.

DWN T. THOMPSON 03-22-95	AMP Incorporated Harrisburg, PA 17105-3608	
CHK D. EABY 04-19-95		
APVD D. EABY 04-19-95		
PRODUCT SPEC		
MATERIAL MOLDED PLASTIC	FINISH BLACK	NAME <b>RECEPTACLE, FLANGED H.V. 7 CONTACT, LGH</b>
DIMENSIONS: 1 IN [mm] TOLERANCES UNLESS OTHERWISE SPECIFIED: 0 PLC ±- 1 PLC ±- 2 PLC ±.04 [1.02] 3 PLC ±.015 [0.38] 4 PLC ±- ANGLES ±- FINISH		SIZE <b>A2</b>
WEIGHT -		CAGE CODE <b>00779</b>
CUSTOMER DRAWING		DRAWING NO <b>C=861647</b>
SCALE 2:1		SHEET 1 OF 1
REV H		

861647