

**PART NUMBER:** EPS150080UPS-P5P-KH**DESCRIPTION:** switching adapter**INPUT**

rated input voltage	100 V ~ 240 V ac
input voltage range	90 V ~ 264 V ac
rated frequency	50~60 Hz
frequency range	47~63 Hz
rated input current	350 mA max.
inrush current	50 A max. (actual test result is 13.2 A)
no load power consumption	0.5 W max.

**OUTPUT**

output voltage	15 V dc at 0.8 A
output min. current	0 A
line regulation	±2% max.
load regulation	±5% max.
over voltage protection	22 V ±1 V
short circuit protection	auto recovery
ripple voltage	150 mV max. (at 20 MHz bandwidth with 22µF/50V capacitance and 104/50V ceramic capacitor)
efficiency	meets Energy Star / CEC Level IV

**SAFETY & EMI**

HI-POT	input to output	3000 V ac at 4 mA for 2 seconds
	input to case	3000 V ac at 4 mA for 2 seconds
insulation resistance	input to output	50MΩ at 500 V dc
safety approvals	UL60950-1 (first edition), CAN/CSA-C22.2 No.950-95	
EMI standard	FCC part 15 class B	
RoHS compliant	yes	

**ENVIRONMENTAL**

storage temperature	-20°C ~ +70° C
operating temperature	0°C ~ +40° C
storage humidity	10~95%
operating humidity	10~95%

**RELIABILITY**

MTBF	50000 hours at 25°C
burn-in	2 hours at 40°C and full load

**PART NUMBER:** EPS150080UPS-P5P-KH**DESCRIPTION:** switching adapter**LABEL**

0.2mm NAME-PLATE:SILVER CHARACTERS BLACK BACKGROUND.

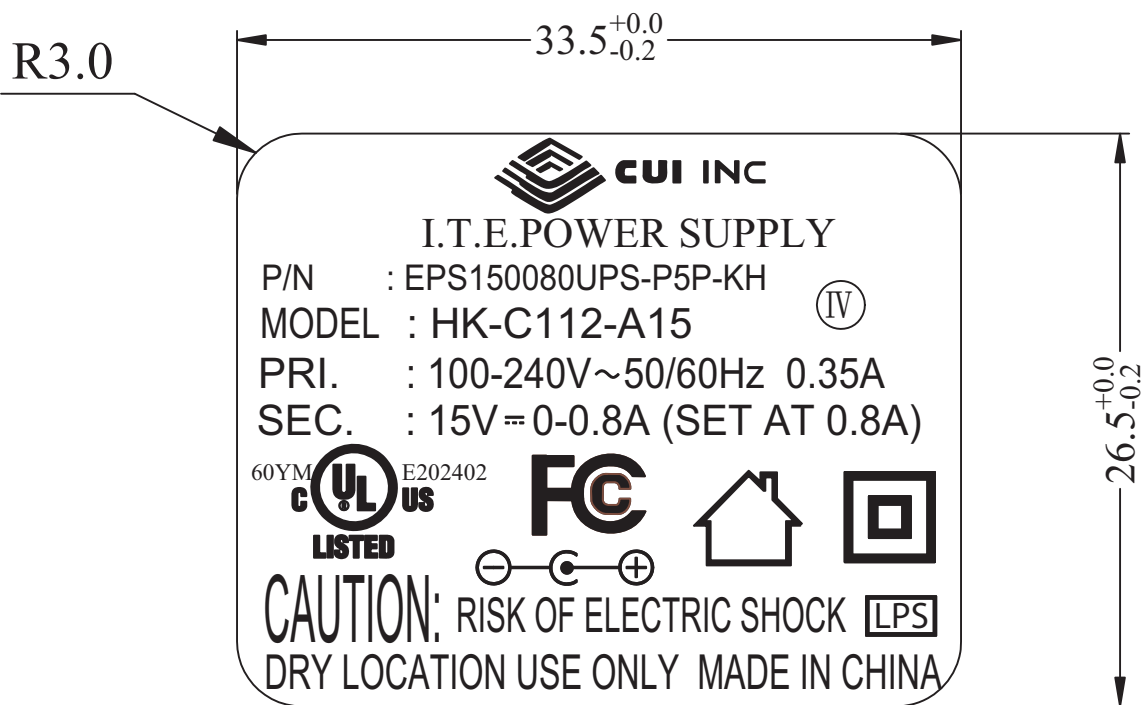

**PART NUMBER:** EPS150080UPS-P5P-KH

**DESCRIPTION:** switching adapter

**MECHANICAL DRAWING**

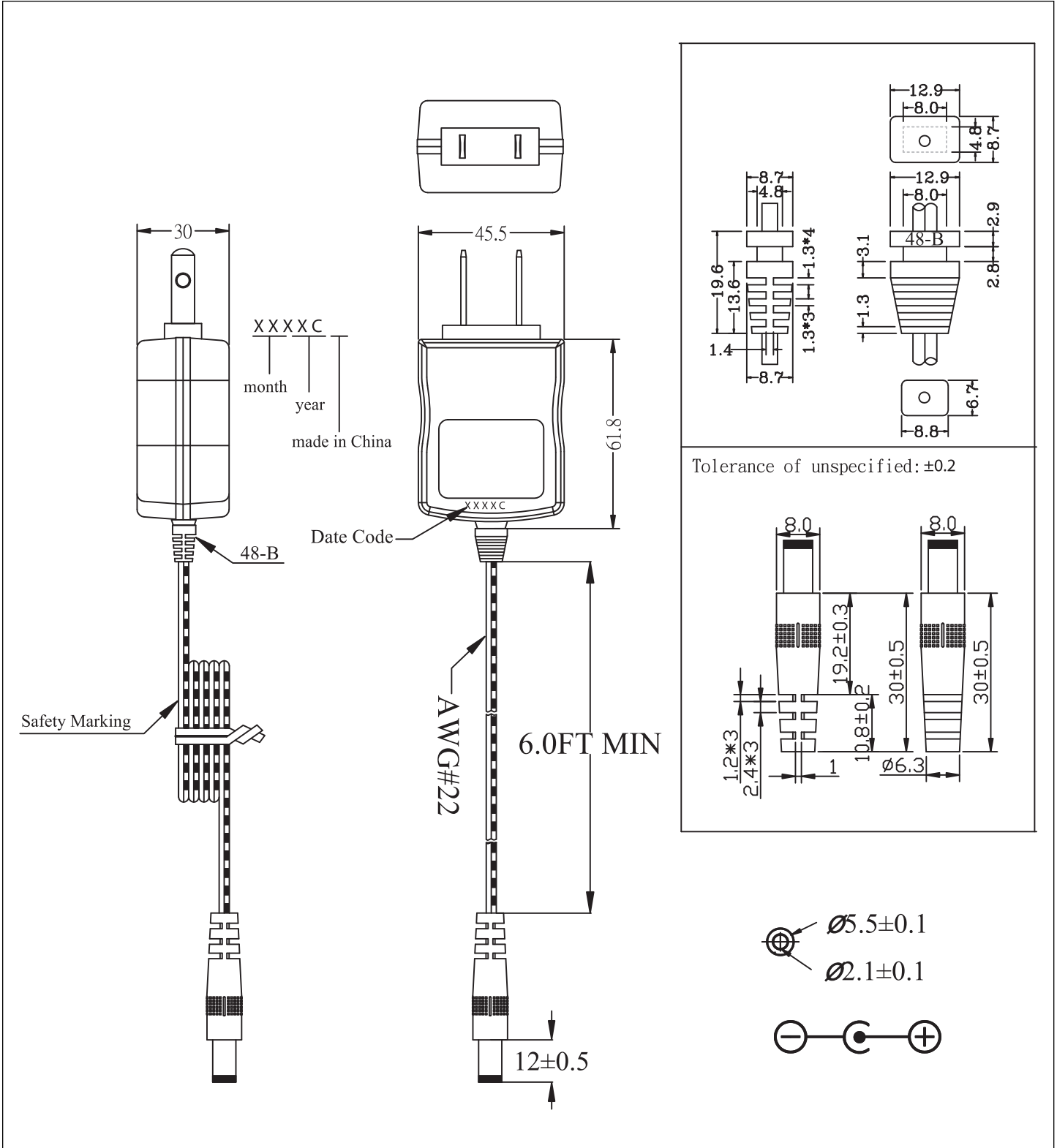

**PART NUMBER:** EPS150080UPS-P5P-KH**DESCRIPTION:** switching adapter**INDIVIDUAL PACKAGING****BUBBLE BAG**

Length: 150

Width: 120

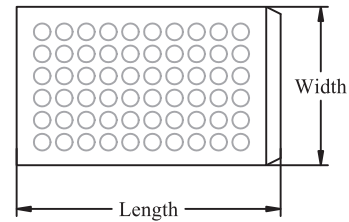
**BOX**

Length: 100

Width: 60

Height: 52

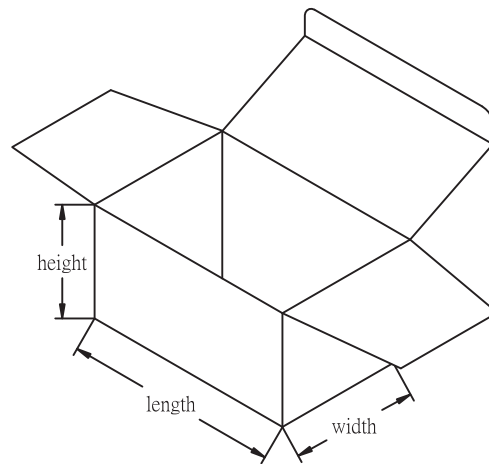

**PART NUMBER:** EPS150080UPS-P5P-KH

**DESCRIPTION:** switching adapter

**PACKAGING**

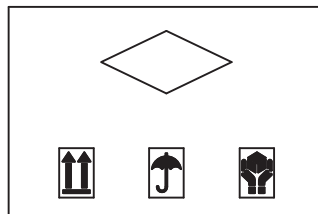

MODEL:  
N.W.:  
G.W.:  
Q'TY: 100PCS

	100V~120V
	200V~240V
	100V~240V

