

THIS DRAWING IS UNPUBLISHED. RELEASED FOR PUBLICATION
 © COPYRIGHT BY TYCO ELECTRONICS CORPORATION. ALL RIGHTS RESERVED.

LOC		DIST		REVISIONS			
P	LTR	DESCRIPTION	DATE	DWN	APVD		
	B	REVISED PER ECO-07-029492	2/22/08	SS	MW		

- COMPONENTS MUST COMPLY WITH EUROPEAN DIRECTIVE 2002/95/EC ON RESTRICTION OF THE USE OF CERTAIN HAZARDOUS SUBSTANCES IN ELECTRICAL AND ELECTRONICS EQUIPMENT (ROHS DIRECTIVE).
- SUPPLIED WITH JAM NUT ASSEMBLED AND SPACER IN PACKAGE BAG.

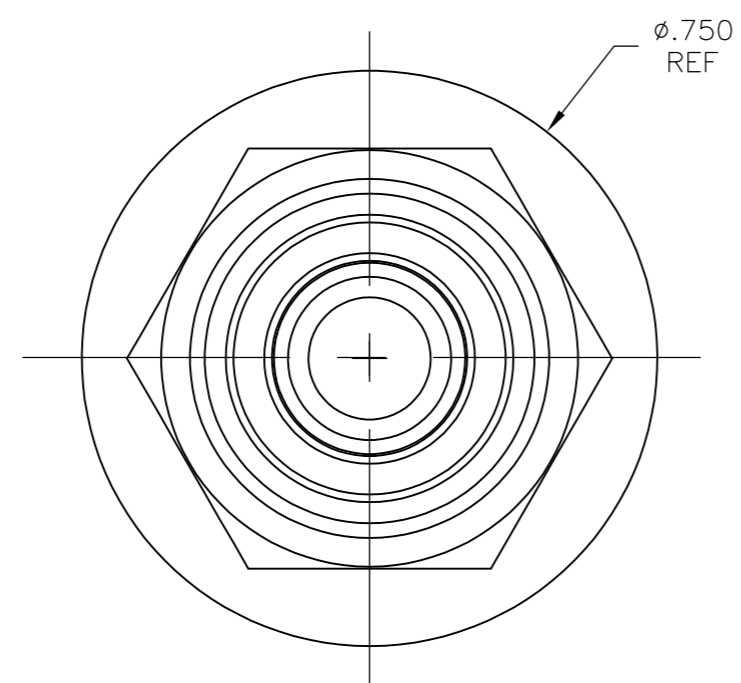
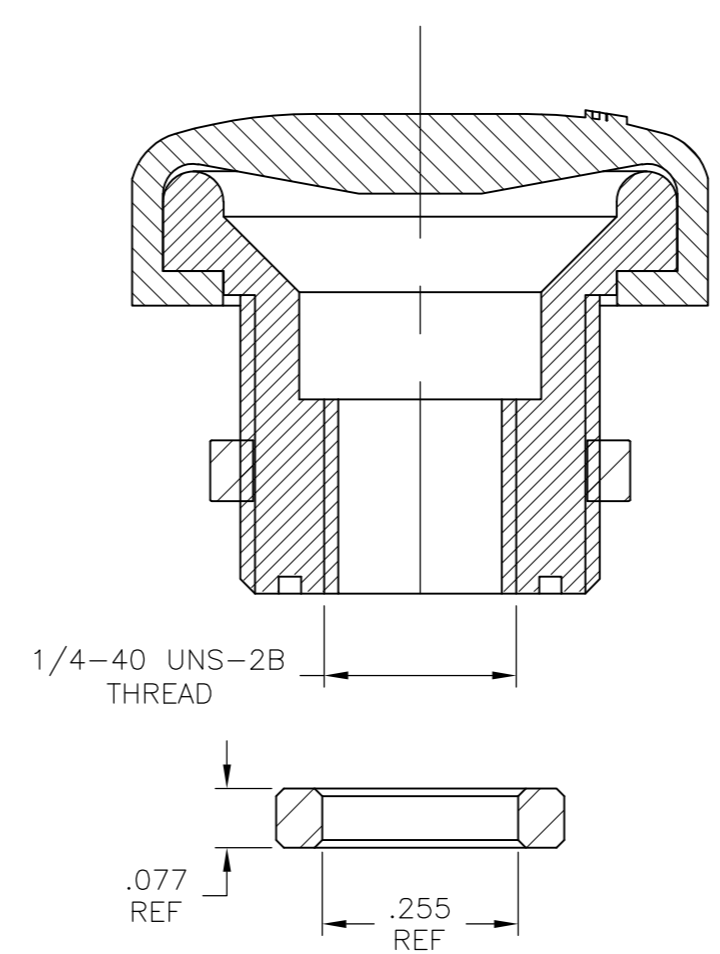
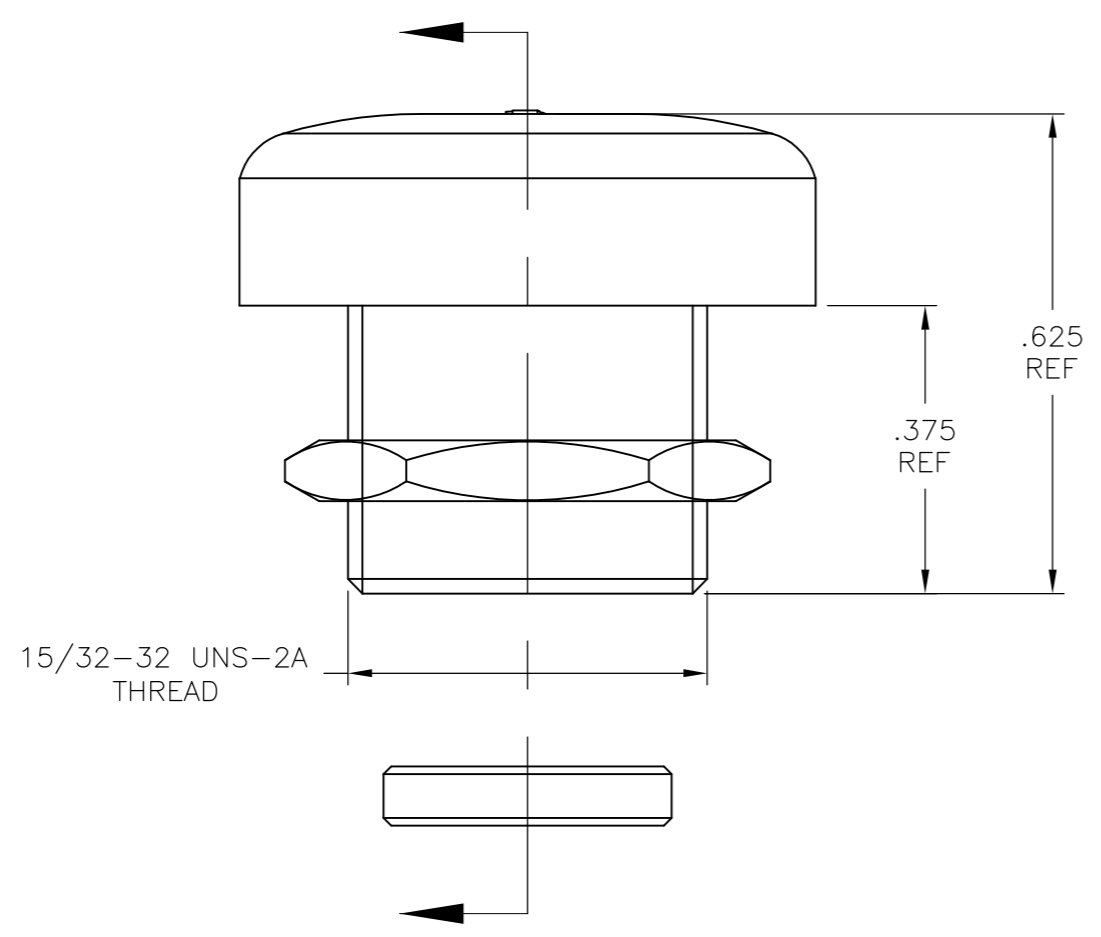
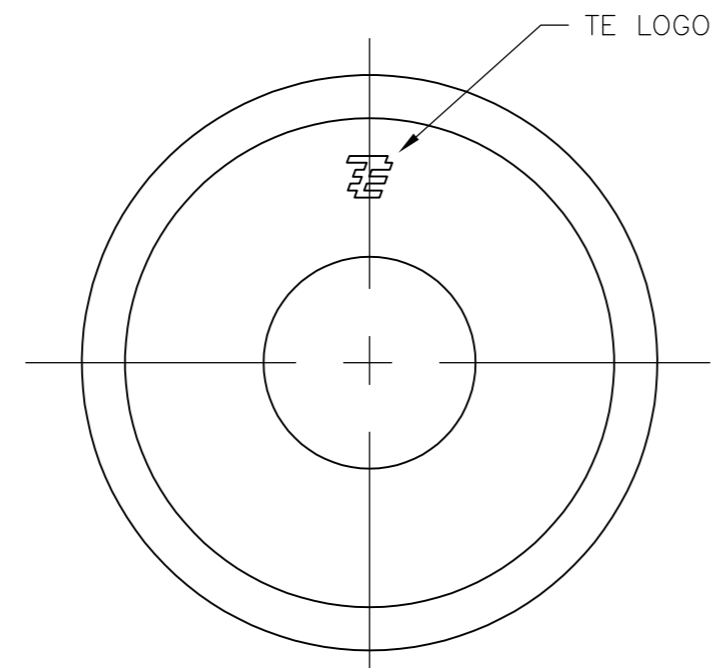

BPM1532804	GRAY	SILICONE PER ZZ-R-765, CLASS 3A, GRADE 60	1825618-3
BPM1532204	RED	SILICONE PER ZZ-R-765, CLASS 3A, GRADE 60	1825618-2
BPM1532004	BLACK	SILICONE PER ZZ-R-765, CLASS 3A, GRADE 60	1825618-1
ALCO NUMBER	CAP COLOR	CAP MATERIAL	PART NUMBER

THIS DRAWING IS A CONTROLLED DOCUMENT.		DWN 22FEB2008 S SCHLEGEL	Tyco Electronics Corporation Harrisburg, PA 17105-3608	
DIMENSIONS: INCHES		CHK 2/22/08 M WILBOURN	NAME BPM PUSHBUTTON SWITCH SEAL	
TOLERANCES UNLESS OTHERWISE SPECIFIED:		APVD 2/22/08 M WILBOURN	SIZE CAGE CODE DRAWING NO RESTRICTED TO	
0 PLC ± -		PRODUCT SPEC	A2 00779 C=1825618	
1 PLC ± -		APPLICATION SPEC	SCALE 4:1 SHEET 1 of 1 REV B	
2 PLC ± .01		WEIGHT -		
3 PLC ± .005		CUSTOMER DRAWING		
4 PLC ± -				
ANGLES ± 5°				
FINISH -				

1825618