

THIS DRAWING IS UNPUBLISHED. RELEASED FOR PUBLICATION 1825059, 1825059
 © COPYRIGHT 1825059 BY TYCO ELECTRONICS CORPORATION. ALL RIGHTS RESERVED.

LOC		DIST		REVISIONS			
P	LTR	DESCRIPTION		DATE	DWN	APVD	
	02	ECO 05 016722		13OCT06	BSV	MS	

SPECIFICATIONS:

MATERIAL

BASE, PPS, UL94V-0, BLACK
 COVER, PPS, UL94V-0, BLACK
 ACTUATOR, PA6T, UL94V-0, WHITE
 FIXED CONTACT/TERMINAL, CU ALLOY-GOLD FLASH OVER NICKEL
 MOVING CONTACT, CU ALLOY, PLATE-GOLD FLASH/NICKEL
 TAPE SEAL-POLYIMIDE FILM, AMBER, SEE P/N TABLE FOR OPTIONS

ELECTRICAL

MAX CONTACT RATING SWITCHING, 100MILLIAMPS @ 24 VDC
 MIN CONTACT RATING SWITCHING, .1MICROAMP @ 1 MILLIVOLT
 MAX CONTACT NON-SWITCHING, 1AMP @ 5 VDC
 INITIAL CONTACT RESISTANCE, 50 MILLIOHMS MAX.
 CONTACT RESISTANCE (AFTER ENVIRONMENTAL TEST), 100 MILLIOHMS
 CONTACT RESISTANCE (AFTER GAS TEST), 300 MILLIOHMS
 INSULATION RESISTANCE, 1,000 MEGOHMS MIN. @ 100 VDC
 DIELECTRIC STRENGTH, 500 VAC RMS @ SEA LEVEL
 LIFE EXPECTANCY, 1,000 CYCLES

MECHANICAL

OPERATING FORCE, LESS THAN 800 GRAMS
 CONTACT PRESSURE, 280,000 PSI

ENVIRONMENTAL

OPERATING TEMPERATURE, -30 TO +85 DEGREES C
 STORAGE TEMPERATURE, -45 TO + 100 DEGREES C
 CLEANING, AQUEOUS OR SOLVENT
 SOLDER HEAT RESISTANCE, PER 109-201, COND B, SWITCH "OFF".
 SOLDERABILITY PER JIS C 0050 & JIS C 0053.

- SWITCHES TO BE RECEIVED IN THE "OFF" POSITION AND PACKAGED IN CLEAR TUBES TO ACCOMMODATE AUTO-INSERTION OR PACKAGED ON TAPE AND REEL
- TOP SURFACE TO BE CLEARLY MARKED AS SHOWN
- SWITCHES TO BE BLACK WITH WHITE ACTUATORS AND MARKINGS.
- TERMINAL OPTION: OLD T&B P/N ADExxS, SA OR SB
 S= OUTSIDE "L" TERMINALS; SA= INSIDE "L" TERMINALS;
 SB= BUTT TERMINALS
- ALL MATERIALS AND FINISHES SHALL COMPLY WITH EU DIRECTIVE 2002/95/EC OF 27JAN2003 (ROHS)
- TOP TAPE SEAL AVAILABLE, SEE TABLE FOR OPTIONS.
- TAPE AND REEL PACKAGING PER EIA 481.

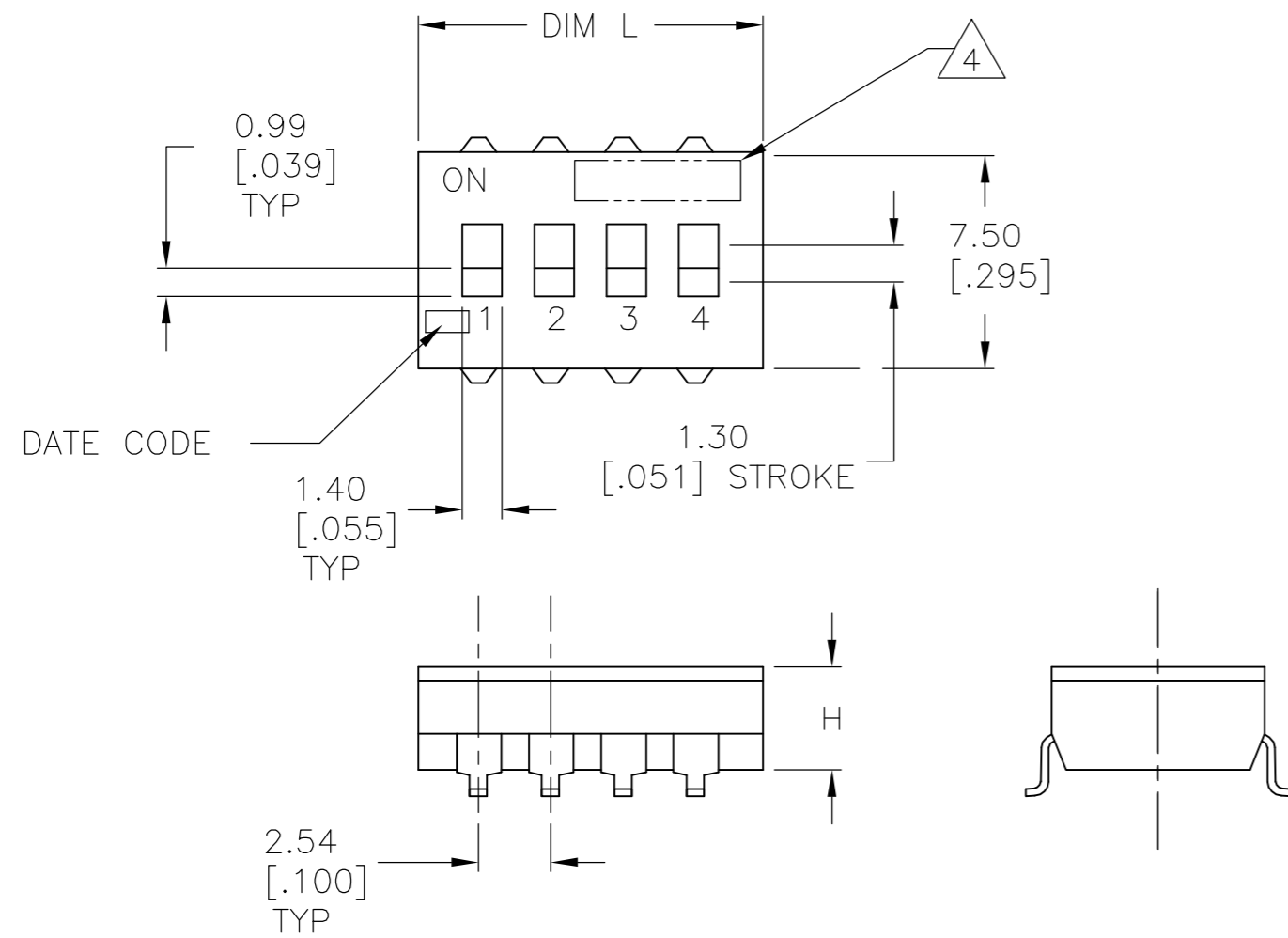

SEE SHEET 3 FOR PART NUMBER TABLE
 SEE SHEET 2 FOR MOUNTING OPTIONS

THIS DRAWING IS A CONTROLLED DOCUMENT.		DWN B.S.VISWESWARA 11FEB05	tyco Tyco Electronics Corporation Harrisburg, PA 17105-3608	
DIMENSIONS: mm [INCHES]	TOLERANCES UNLESS OTHERWISE SPECIFIED:	CHK M.SARVER	NAME M.SARVER	DIP SWITCH, ADF-SMT SERIES
	0 PLC ± - 1 PLC ± - 2 PLC ± 0.30[.012] 3 PLC ± - 4 PLC ± - ANGLES ± -	APVD M.SARVER	PRODUCT SPEC	
MATERIAL	FINISH	APPLICATION SPEC	SIZE A2	CAGE CODE -
		WEIGHT -	DRAWING NO C=1825059	RESTRICTED TO -
CUSTOMER DRAWING			SCALE 4:1	SHEET 1 of 3
			REV 02	

THIS DRAWING IS UNPUBLISHED. RELEASED FOR PUBLICATION 1825059, 1825059
 © COPYRIGHT 1825059 BY TYCO ELECTRONICS CORPORATION. ALL RIGHTS RESERVED.

LOC		DIST		REVISIONS			
P	LTR	DESCRIPTION	DATE	DWN	APVD		
		SEE SHEET 1					

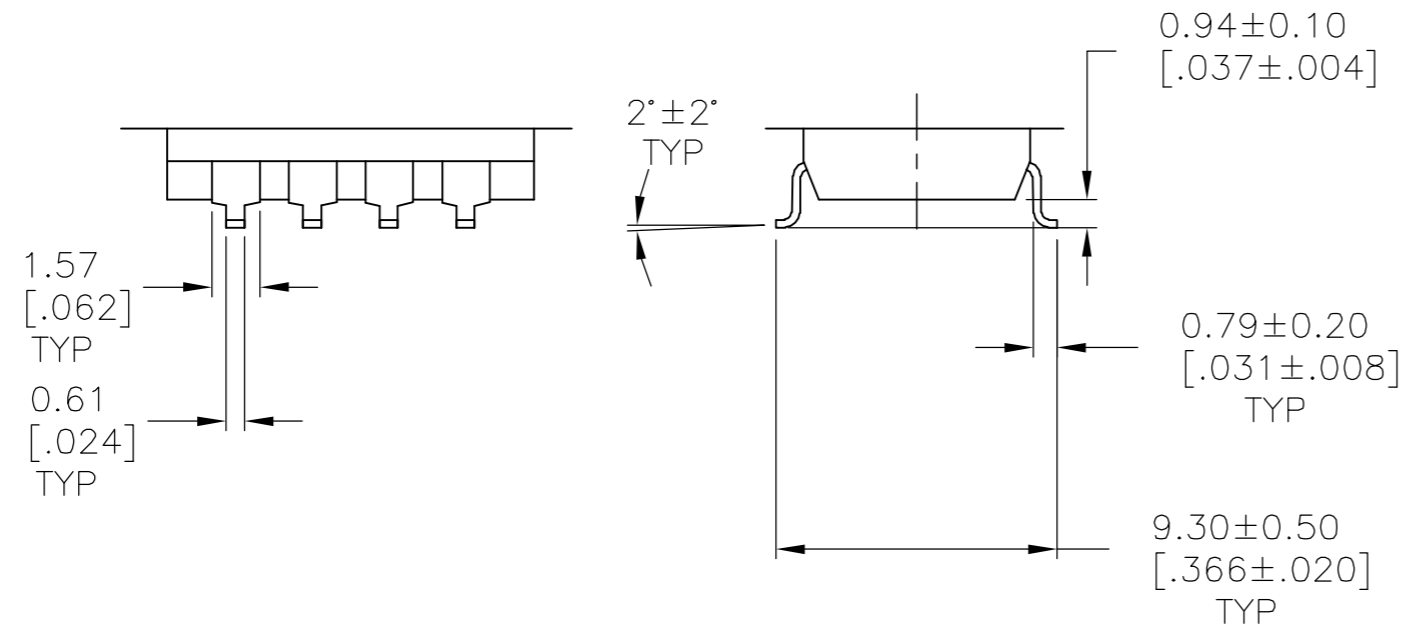

SURFACE MOUNT
S (OUTSIDE "L")

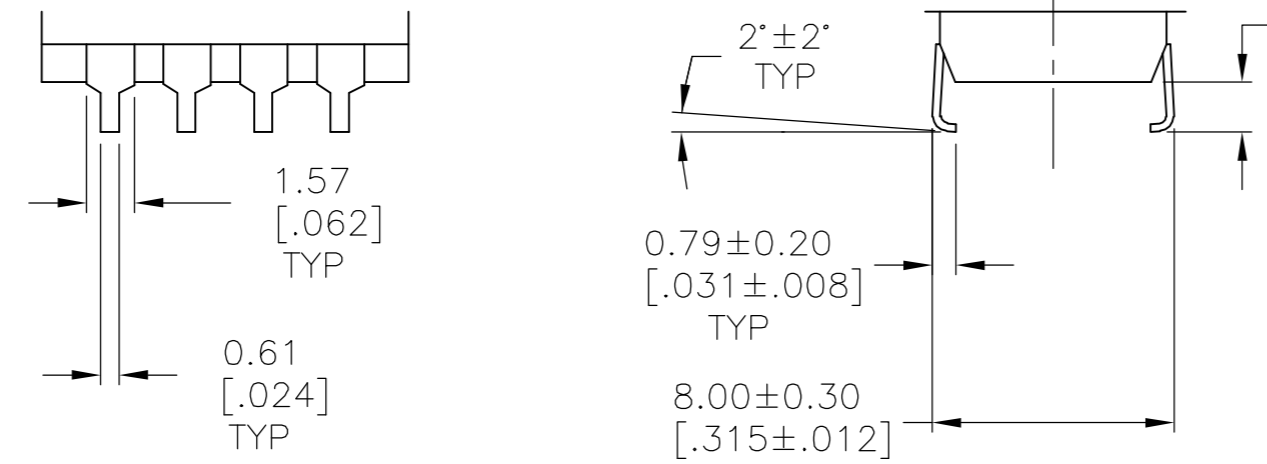

SURFACE MOUNT
SA (INSIDE "L")

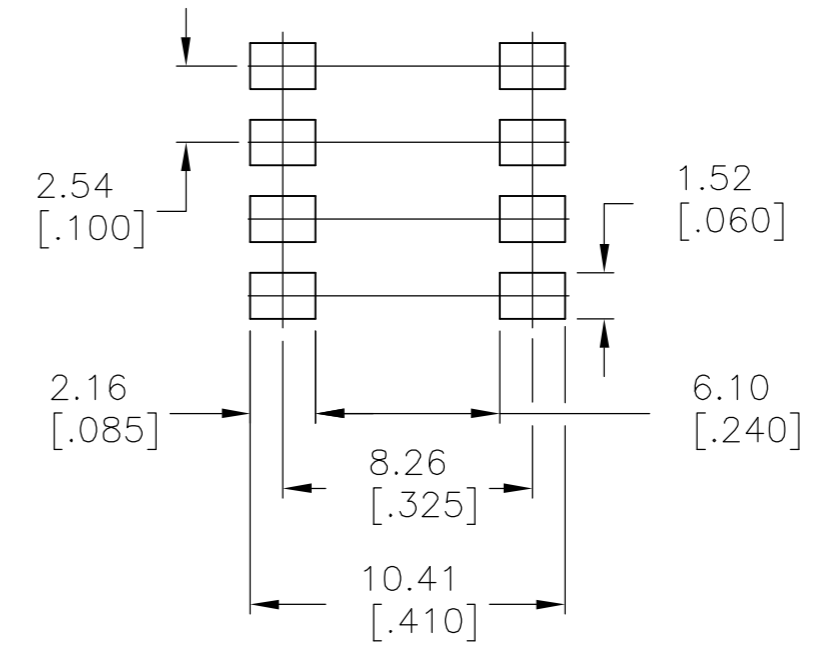

RECOMMENDED PAD LAYOUT

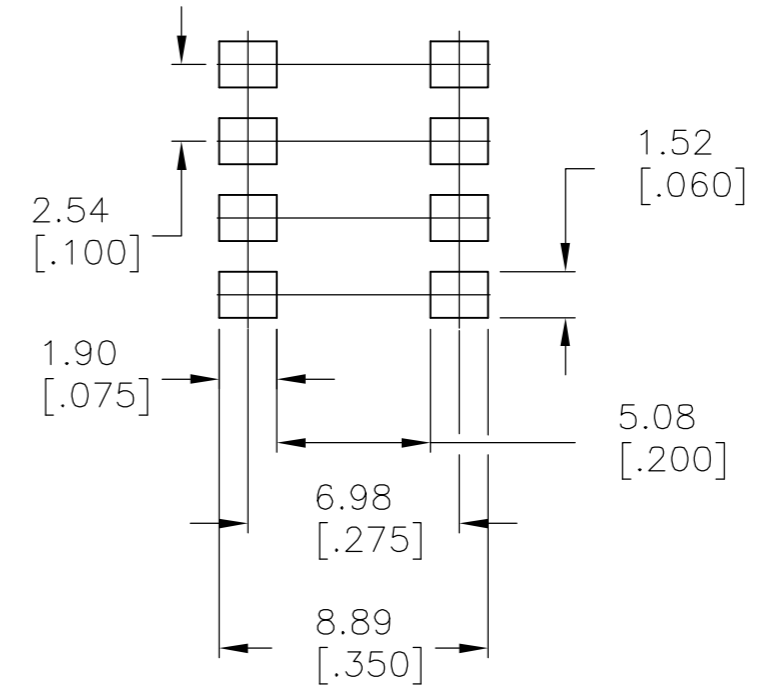

RECOMMENDED PAD LAYOUT

THIS DRAWING IS A CONTROLLED DOCUMENT.		DWN B.S.VISWESWARA 11FEB05	Tyco Electronics Corporation Harrisburg, PA 17105-3608	
DIMENSIONS: mm [INCHES]	TOLERANCES UNLESS OTHERWISE SPECIFIED:	CHK M.SARVER	NAME	
	0 PLC ± -	APVD M.SARVER	DIP SWITCH, ADF-SMT SERIES	
	1 PLC ± -	PRODUCT SPEC	SIZE	CAGE CODE
	2 PLC ± 0.30[.012]	APPLICATION SPEC	A2	-
	3 PLC ± -	WEIGHT	DRAWING NO	
MATERIAL	FINISH	RESTRICTED TO		SCALE
-	-	-		4:1
CUSTOMER DRAWING		SHEET		REV
		2 of 3		02

THIS DRAWING IS UNPUBLISHED. RELEASED FOR PUBLICATION 1825059, 1825059
 © COPYRIGHT 1825059 BY TYCO ELECTRONICS CORPORATION. ALL RIGHTS RESERVED.

Loc		DIST		REVISIONS			
AD	00	P	LTR	DESCRIPTION	DATE	DWN	APVD
		-		SEE SHEET 1	-	-	-

ADF09S04	3.50[.138]	24.54[.978]	NO	9	4-1825059-3
ADF08STTR04	3.50[.138]	22.30[.878]	YES	8	4-1825059-2
ADF08ST04	3.50[.138]	22.30[.878]	YES	8	4-1825059-1
ADF08SATTR04	3.50[.138]	22.30[.878]	YES	8	4-1825059-0
ADF08SAT04	3.50[.138]	22.30[.878]	YES	8	3-1825059-9
ADF08SA04	3.50[.138]	22.30[.878]	NO	8	3-1825059-8
ADF08S04	3.50[.138]	22.30[.878]	NO	8	3-1825059-7
ADF07STTR04	3.50[.138]	19.76[.778]	YES	7	3-1825059-6
ADF07ST04	3.50[.138]	19.76[.778]	YES	7	3-1825059-5
ADF07SATTR04	3.50[.138]	19.76[.778]	YES	7	3-1825059-4
ADF07SAT04	3.50[.138]	19.76[.778]	YES	7	3-1825059-3
ADF07SA04	3.50[.138]	19.76[.778]	NO	7	3-1825059-2
ADF07S04	3.50[.138]	19.76[.778]	NO	7	3-1825059-1
ADF06STTR04	3.50[.138]	17.22[.678]	YES	6	3-1825059-0
ADF06ST04	3.50[.138]	17.22[.678]	YES	6	2-1825059-9
ADF06SATTR04	3.50[.138]	17.22[.678]	YES	6	2-1825059-8
ADF06SAT04	3.50[.138]	17.22[.678]	YES	6	2-1825059-7
ADF06SA04	3.50[.138]	17.22[.678]	NO	6	2-1825059-6
ADF06S04	3.50[.138]	17.22[.678]	NO	6	2-1825059-5
ADF05STTR04	3.50[.138]	14.68[.578]	YES	5	2-1825059-4
ADF05ST04	3.50[.138]	14.68[.578]	YES	5	2-1825059-3
ADF05SATTR04	3.50[.138]	14.68[.578]	YES	5	2-1825059-2
ADF05SAT04	3.50[.138]	14.68[.578]	YES	5	2-1825059-1
ADF05SA04	3.50[.138]	14.68[.578]	NO	5	2-1825059-0
ADF05S04	3.50[.138]	14.68[.578]	NO	5	1-1825059-9
ADF04STTR04	3.50[.138]	12.14[.478]	YES	4	1-1825059-8
ADF04ST04	3.50[.138]	12.14[.478]	YES	4	1-1825059-7
ADF04SATTR04	3.50[.138]	12.14[.478]	YES	4	1-1825059-6
ADF04SAT04	3.50[.138]	12.14[.478]	YES	4	1-1825059-5
ADF04SA04	3.50[.138]	12.14[.478]	NO	4	1-1825059-4
ADF04S04	3.50[.138]	12.14[.478]	NO	4	1-1825059-3
ADF03STTR04	3.50[.138]	9.60[.378]	YES	3	1-1825059-2
ADF03ST04	3.50[.138]	9.60[.378]	YES	3	1-1825059-1
ADF03SATTR04	3.50[.138]	9.60[.378]	YES	3	1-1825059-0
ADF03SAT04	3.50[.138]	9.60[.378]	YES	3	1825059-9
ADF03SA04	3.50[.138]	9.60[.378]	NO	3	1825059-8
ADF03S04	3.50[.138]	9.60[.378]	NO	3	1825059-7
ADF02STTR04	3.50[.138]	7.06[.278]	YES	2	1825059-6
ADF02ST04	3.50[.138]	7.06[.278]	YES	2	1825059-5
ADF02SATTR04	3.50[.138]	7.06[.278]	YES	2	1825059-4
ADF02SAT04	3.50[.138]	7.06[.278]	YES	2	1825059-3
ADF02SA04	3.50[.138]	7.06[.278]	NO	2	1825059-2
ADF02S04	3.50[.138]	7.06[.278]	NO	2	1825059-1
T&B P/N	DIM H	DIM L	SEAL	POS	TYCO P/N

ADF12STTR04	3.61[.142]	32.51[1.280]	YES	12	6-1825059-0
ADF12ST04	3.61[.142]	32.51[1.280]	YES	12	5-1825059-9
ADF12SATTR04	3.61[.142]	32.51[1.280]	YES	12	5-1825059-8
ADF12SAT04	3.61[.142]	32.51[1.280]	YES	12	5-1825059-7
ADF12SA04	3.61[.142]	32.51[1.280]	NO	12	5-1825059-6
ADF12S04	3.61[.142]	32.51[1.280]	NO	12	5-1825059-5
ADF10STTR04	3.50[.138]	27.36[1.078]	YES	10	5-1825059-4
ADF10ST04	3.50[.138]	27.36[1.078]	YES	10	5-1825059-3
ADF10SATTR04	3.50[.138]	27.36[1.078]	YES	10	5-1825059-2
ADF10SAT04	3.50[.138]	27.36[1.078]	YES	10	5-1825059-1
ADF10SA04	3.50[.138]	27.36[1.078]	NO	10	5-1825059-0
ADF10S04	3.50[.138]	27.36[1.078]	NO	10	4-1825059-9
ADF09STTR04	3.50[.138]	24.54[.978]	YES	9	4-1825059-8
ADF09ST04	3.50[.138]	24.54[.978]	YES	9	4-1825059-7
ADF09SATTR04	3.50[.138]	24.54[.978]	YES	9	4-1825059-6
ADF09SAT04	3.50[.138]	24.54[.978]	YES	9	4-1825059-5
ADF09SA04	3.50[.138]	24.54[.978]	NO	9	4-1825059-4
T&B P/N	DIM H	DIM L	SEAL	POS	TYCO P/N

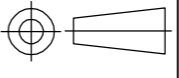
THIS DRAWING IS A CONTROLLED DOCUMENT.		DWN B.S.VISWESWARA 11FEB05	 Tyco Electronics Corporation Harrisburg, PA 17105-3608	
DIMENSIONS: mm [INCHES]		CHK M.SARVER	NAME	
TOLERANCES UNLESS OTHERWISE SPECIFIED:		APVD M.SARVER	DIP SWITCH, ADF-SMT SERIES	
 0 PLC ± - 1 PLC ± - 2 PLC ± 0.30[.012] 3 PLC ± - 4 PLC ± - ANGLES ± - FINISH -		PRODUCT SPEC -	APPLICATION SPEC -	RESTRICTED TO -
MATERIAL -	WEIGHT -	SIZE A2	CAGE CODE -	DRAWING NO C=1825059
CUSTOMER DRAWING		SCALE 4:1	SHEET 3 of 3	REV 02