









SLEEVES		
	2mm	Light Sky Blue
	3mm	Orange
	1/8 inch (3.175mm)	Purple1
	4mm	Gray60
	3/16 inch (4.76mm)	Yellow1
	5mm	Green1
	6mm	Red1
	1/4 inch (6.35mm)	Snow
	8mm	Blue



ASSEMBLY

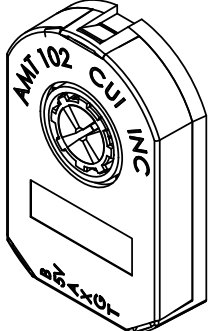
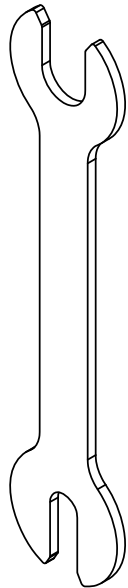
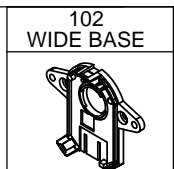
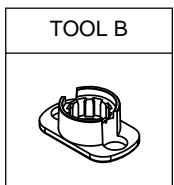
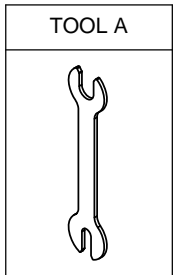
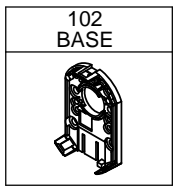
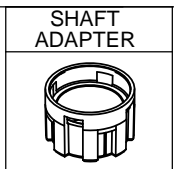
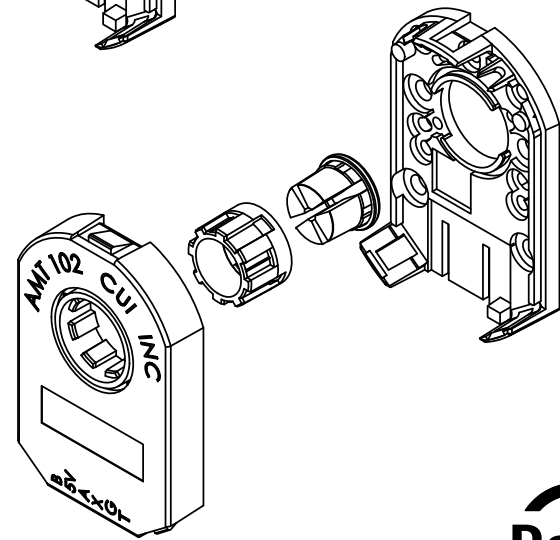
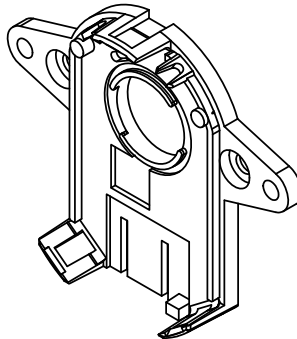
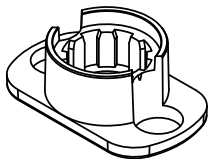

PIN-OUT	
PIN	DESCRIPTION
B	B CHANNEL
5V	+5VDC POWER
A	A CHANNEL
X	INDEX OUPUT
G	GROUND
T	FOR FUTURE USE

MATING CONNECTOR
MOLEX 50-57-9405 HOUSING
MOLEX 16-02-0086 TERMINALS

CABLES AVAILABLE
(SOLD SEPERATELY)



AMT102 VersaPak comes with all items shown: all Sleeve sizes, Shaft Adapter, Base, Wide Base, Top Cover, Tool A, Tool B, Index Pulse, and 16 Resolution Dip Switch.

Sleeve Sizes
The AMT comes with sleeve adapters to fit the following bore diameters: 2mm, 3mm, 3.17mm (1/8"), 4mm, 4.76mm (3/16"), 5mm, 6mm, 6.35mm (1/4"), 8mm.

Operational Specs
3.6 Vdc~5.5Vdc; Max power consumption 10mA
Temp Range: -40 ~ +100°C
Current consumption: 6mA (typ), 10mA max

Resolution Options (PPR)
All resolutions stated are before quadrature decoding (example: 1000PPR x 4 = 4000 counts).

Resolutions of AMT102 VersaPak = 48, 96, 100, 125, 196, 200, 250, 256, 384, 400, 500, 512, 800, 1000, 1024, 2048.

Max RPM	Resolutions
7500	2048, 1000, 800, 384 (plus res. from 15k and 30k RPM)
15000	1024, 500, 400, 192 (plus res. from 30k RPM)
30000	512, 250, 200, 96; 256, 125, 100, 48

Mounting Hole Options (see dim drawing for layout)
2 each M1.6 holes on 16mm (.63") bolt circle
2 each #4 holes on 19.05 (.75") bolt circle
2 each M1.6 or M2 holes on 20mm (.787") bolt circle
3 each M1.6 or M2 holes on 20.9mm (.823") bolt circle
3 each M1.6 or M2 holes on 22mm (.866") bolt circle
4 each M1.6 or M2 holes on 25.4mm (1") bolt circle
2 each #4 holes on 15.75mm (0.62") x 20.96 (0.825") hole layout
2 each #4 holes on 32.43mm (1.277") bolt circle
2 each #4 holes on 46.03mm (1.812") bolt circle

Note: Some stepper motors may leak a magnetic field causing the AMT index pulse to not function properly.



20050 SW 112th Ave.
Tualatin, OR 97062
Phone: 503-612-2300
800-275-4899
Fax: 503-612-2383
Website: www.cui.com

TITLE: AMT102 VersaPak		REV: C
PART NO. AMT102-V		UNITS: MM [INCHES]
DRAWN BY: ZRJ	APPROVED BY:	SCALE: N/A

PC FILE NAME:
AMT102-V-REV-C

COPYRIGHT 2007 BY CUI INC.

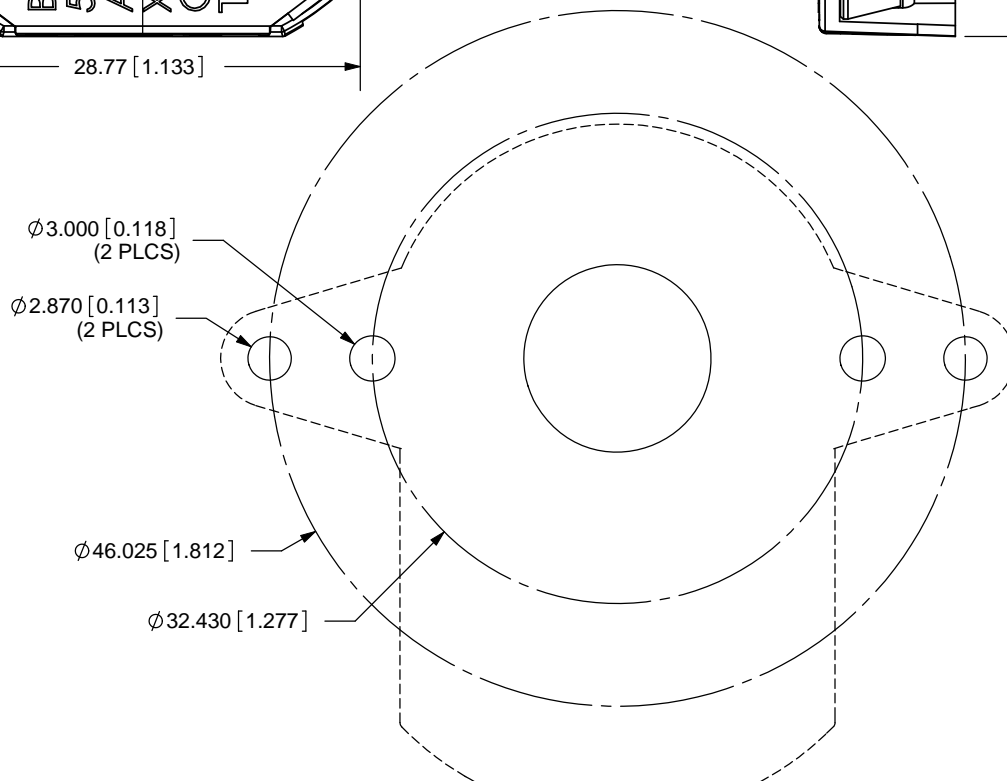
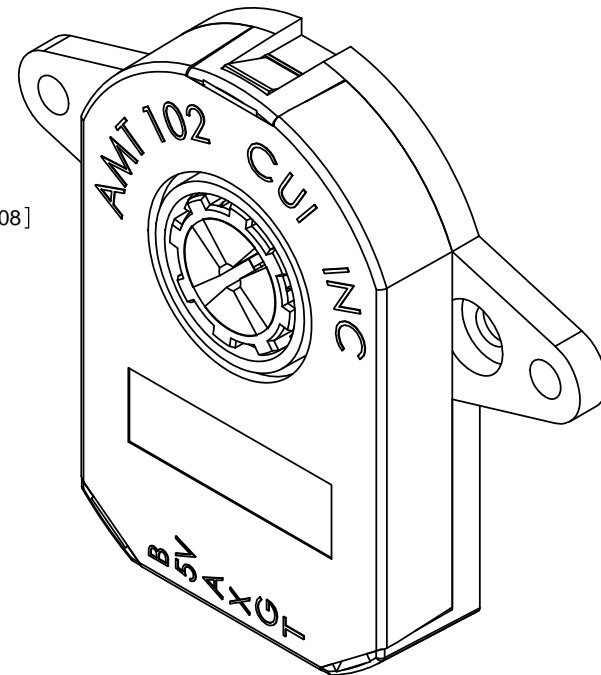
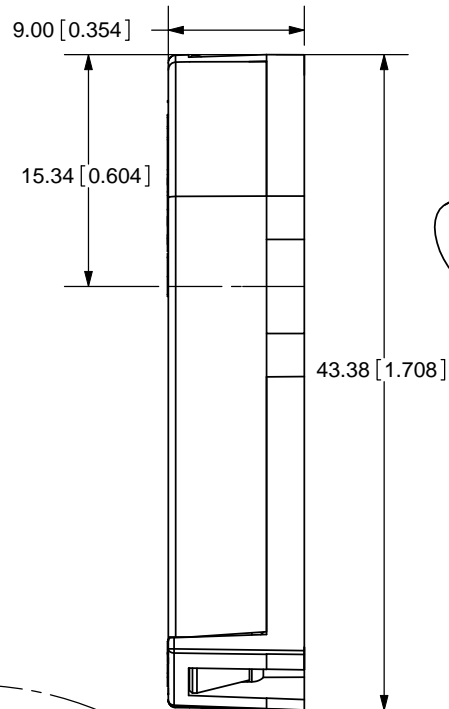
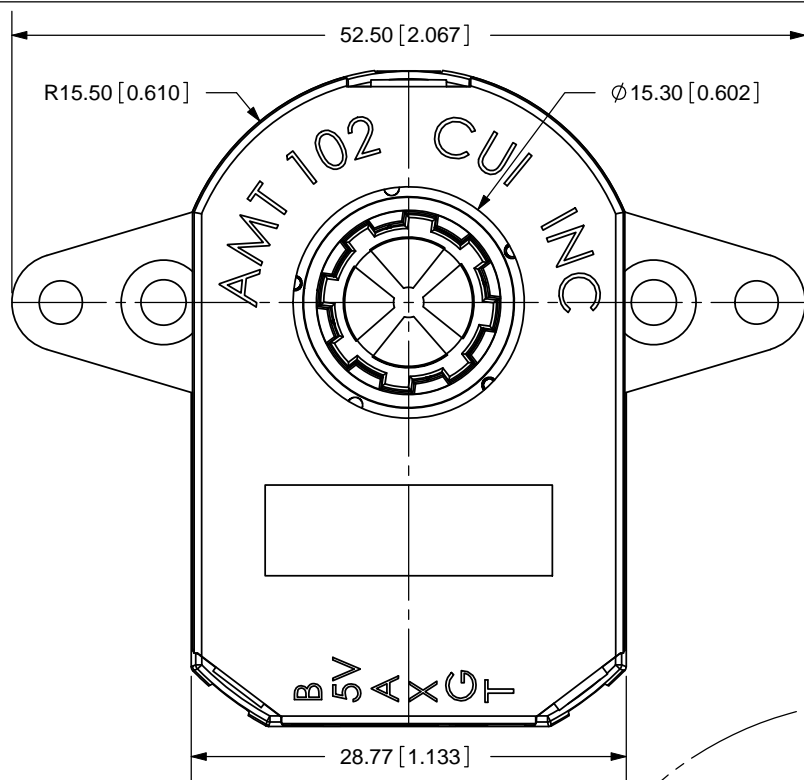

TOLERANCE:
 $\pm 0.05\text{mm}$ UNLESS OTHERWISE
 SPECIFIED



20050 SW 112th Ave.
 Tualatin, OR 97062
 Phone: 503-612-2300
 800-275-4899
 Fax: 503-612-2383
 Website: www.cui.com

TITLE: AMT102 WIDE BASE DIMENSION DRAWING		REV: C
PART NO. AMT102 WIDE BASE	UNITS: MM [INCHES]	
DRAWN BY: ZRJ	APPROVED BY:	SCALE: 2:1

PC FILE NAME:
 AMT102-dim-WB-REV-C

COPYRIGHT 2008 BY CUI INC.