

THIS DRAWING IS UNPUBLISHED. RELEASED FOR PUBLICATION
 © COPYRIGHT BY TYCO ELECTRONICS CORPORATION. ALL RIGHTS RESERVED.

Loc		DIST		REVISIONS			
P	LTR	DESCRIPTION		DATE	DWN	APVD	
AD	00	H1	ECO-05-15373	20SEP06	MB	MS	

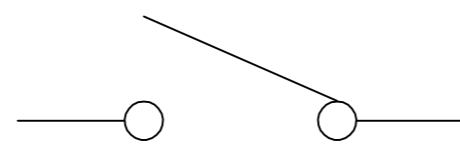
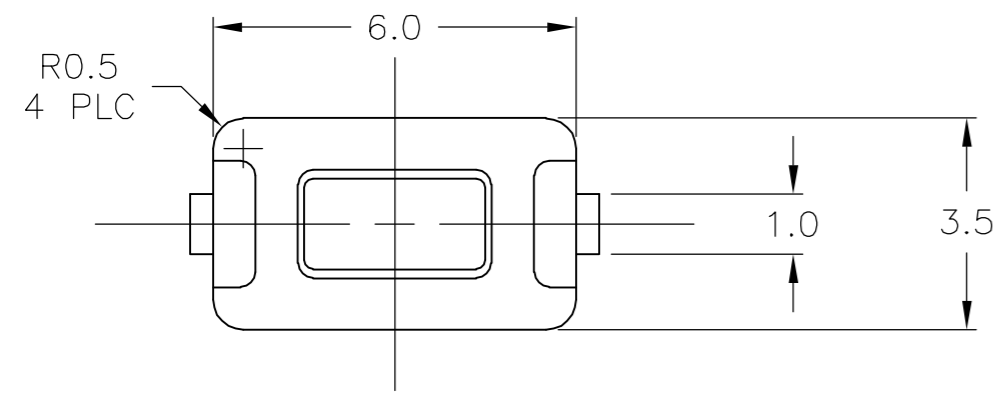

CIRCUIT DIAGRAM

MATERIALS:

CASE: PPS, 30% GLASS, UL94V-0, COLOR-SEE TABLE
 COVER: STAINLESS STEEL
 ACTUATOR: SEE TABLE
 MOVING CONTACT: STAINLESS STEEL, SILVER PLATE
 FIXED CONTACT/TERMINAL: COPPER ALLOY, SILVER OR TIN OVER NICKEL

ELECTRICAL:

CONTACT RATING: 50mA 12 VDC
 INITIAL CONTACT RESISTANCE: 100 MILLIOHMS MAX
 INSULATION RESISTANCE: 100 MEGAOHMS @ 100 VDC MIN
 DIELECTRIC STRENGTH: 500 VDC 50/60 HZ FOR 1 MINUTE
 LIFE EXPECTANCY: UP TO 40,000 CYCLES

MECHANICAL:

ACTUATION FORCE: SEE TABLE
 ACTUATION TRAVEL: 0.25 +0.2/-0.1

ENVIRONMENTAL:

OPERATING TEMPERATURE: -31°F TO 185°F (-35°C TO 85°C)
 SOLDERABILITY: PER EIA-364-52, CLASS 1, CATEGORY 2
 SOLDER HEAT RESISTANCE: PER 109-201, CONDITION B

PACKAGING:

TAPE AND REEL PACKAGING PER EIA 481, 2000 PER REEL

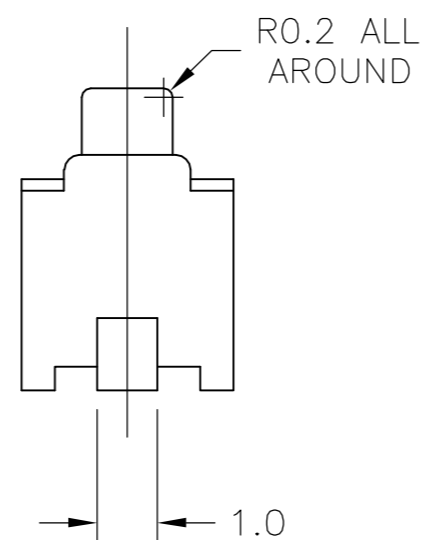
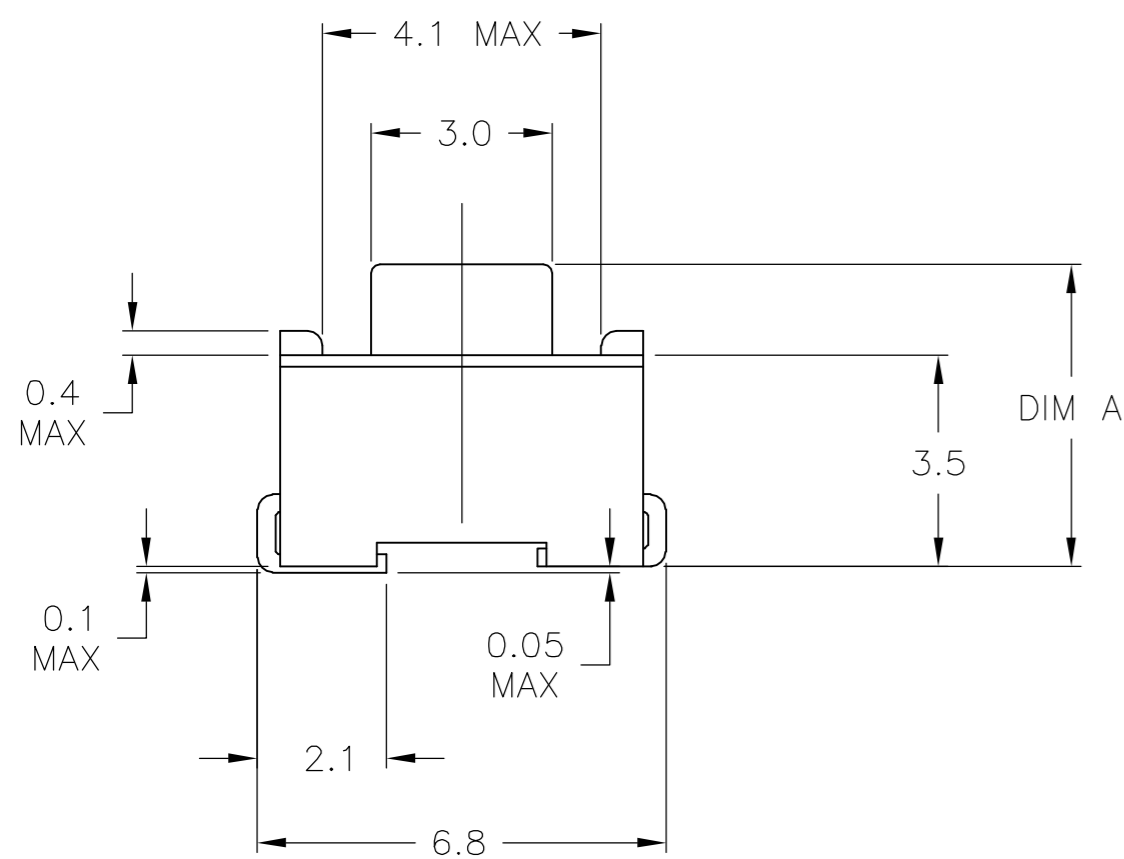

1 PRELIMINARY PART - NOT RELEASED FOR PRODUCTION.

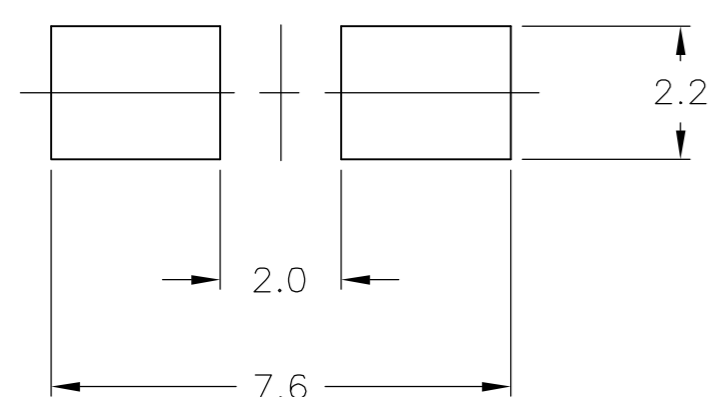

SOLDER LAND DIMENSION

1	G	8mm	16mm	GREEN	NYLON 4/6	TIN	2.0	3.5	180±50gf	147873-6
	G	8mm	16mm	GREEN	NYLON 4/6	TIN	3.5	4.3	180±50gf	147873-5
1	G	8mm	16mm	GREEN	PPS	TIN	3.5	5.0	180±50gf	147873-4
	H	8mm	16mm	BLACK	NYLON 4/6	SILVER	2.0	3.5	180±50gf	147873-3
	H	8mm	16mm	BLACK	NYLON 4/6	SILVER	3.5	4.3	180±50gf	147873-2
	G	8mm	16mm	BLACK	PPS	SILVER	3.5	5.0	180±50gf	147873-1
	PART REVISION	TAPE PITCH	TAPE WIDTH	ACTUATOR COLOR	ACTUATOR MATERIAL	CONTACT FINISH	DIM B	DIM A	ACTUATION FORCE	PART NUMBER

THIS DRAWING IS A CONTROLLED DOCUMENT.

DWN	R BROWN	03OCT01
CHK	H WYNKOOP	03OCT2001
APVD	H WYNKOOP	03OCT2001
PRODUCT SPEC	-	
APPLICATION SPEC	-	
WEIGHT	-	
CUSTOMER DRAWING	-	

tyco Electronics Tyco Electronics Corporation
Harrisburg, Pa 17105-3608

NAME: SWITCH, TACTILE, SMT

SIZE	A2	CAGE CODE	00779	DRAWING NO	C=147873	RESTRICTED TO	-
SCALE	8:1	SHEET	1	OF	1	REV	H1