

CIRCUIT: SPST

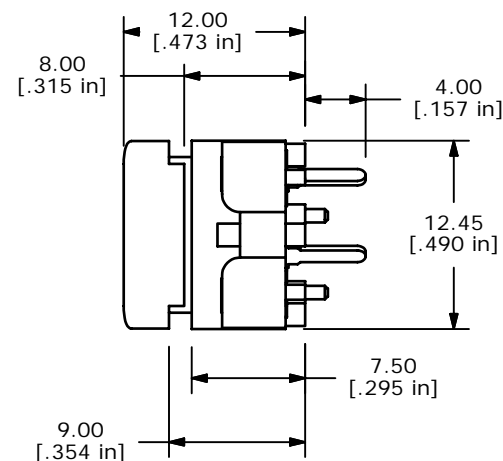
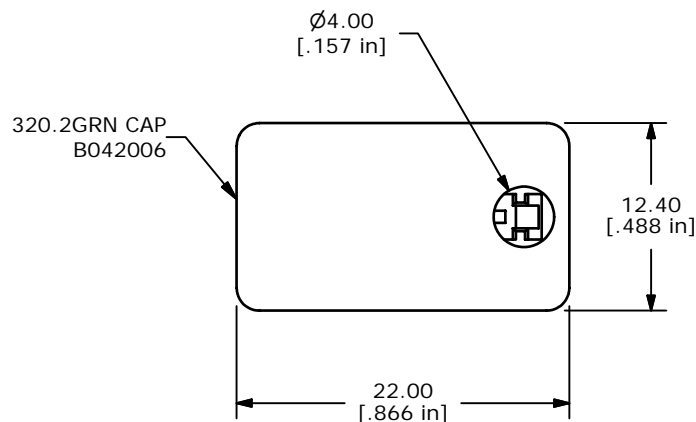

NOTES:

1. ALL DIMENSIONS IN MM [INCH]
2. GENERAL TOLERANCE X.X=±0.4
X.XX=±0.25
3. TERMINAL NUMBERS FOR REF. ONLY
4. CONTACT RATING: 25mA, 50 VDC
5. TRAVEL: 0.7mm
6. OPERATING FORCE: 120gf
- ▲ 7. USES E1-1 CONTACT DOME (B050001)
8. ▲ DENOTES CRITICAL PARAMETER.

E-SWITCH®

TITLE 320.2E11GRN W/ LED HOLDER

A	15845	NEW RELEASE	3/6/06	PH
REV	PCR NO	DESCRIPTION	DATE	BY

SCALE	DATE	DR	DWG	REV
2:1	3/6/2006	PH	XB0787A	A

THE INFORMATION CONTAINED IN THIS DOCUMENT IS PROPRIETARY TO E-SWITCH AND IS NOT TO BE COPIED OR TRANSFERRED