

CIRCUIT: SPST

320.2 YELLOW CAP  
B042007

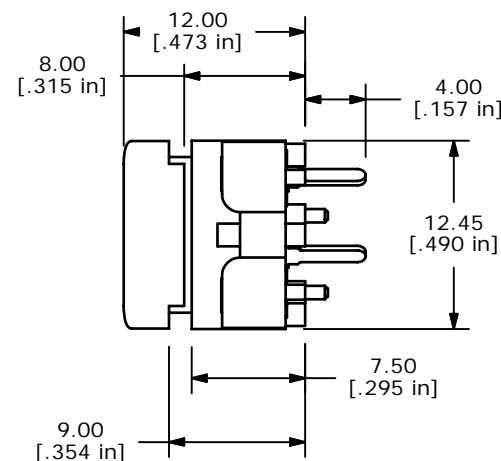
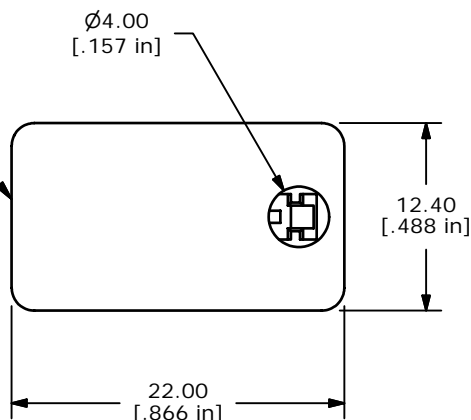

NOTES:

1. ALL DIMENSIONS IN MM [INCH]
2. GENERAL TOLERANCE X.X=±0.4  
X.XX=±0.25
3. TERMINAL NUMBERS FOR REF. ONLY
4. CONTACT RATING: 25mA, 50 VDC
5. TRAVEL: 0.7mm
6. OPERATING FORCE: 120gf
- ▲ 7. USES E1-1 CONTACT DOME (B050001)
8. ▲ DENOTES CRITICAL PARAMETER.



B	15987	UPDATE CAP CALLOUT	4/25/06	CT
A	15793	NEW RELEASE	2/20/06	PH
REV	PCR NO	DESCRIPTION	DATE	BY

TITLE 320.2E11YEL W/ LED HOLDER				
SCALE	DATE	DR	DWG	REV
2:1	2/14/2006	PH	XB0781A	B

THE INFORMATION CONTAINED IN THIS DOCUMENT IS PROPRIETARY TO E-SWITCH AND IS NOT TO BE COPIED OR TRANSFERRED