

SWITCH FUNCTION	
POS. 1	POS. 2
ON	(ON)
1-3, 4-6	1-2, 4-5

(ON) = MOMENTARY

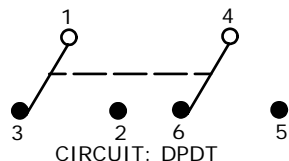

NOTE:

- ALL DIMENSIONS IN MM [INCH]
- GENERAL TOLERANCE: X.X=±0.4
X.XX=±0.25
- TERMINAL NUMBERS FOR REF ONLY
- ▲ CONTACT MATERIAL: SILVER
- RATING: 3A @ 120VAC OR 28VDC
1A @ 250VAC
- ELECTRIC LIFE: 50,000 MAKE-AND-BREAK CYCLES AT FULL LOAD
- INSULATION RESISTANCE: 1,000 MEGA-OHM MIN.
- DIELECTRIC STRENGTH: 1,000 V RMS @ SEA LEVEL.
- OPERATING TEMP.: -30°C to 85°C
- ▲ DENOTES CRITICAL PARAMETER.
- 2002/95/EC (ROHS) COMPLIANT.

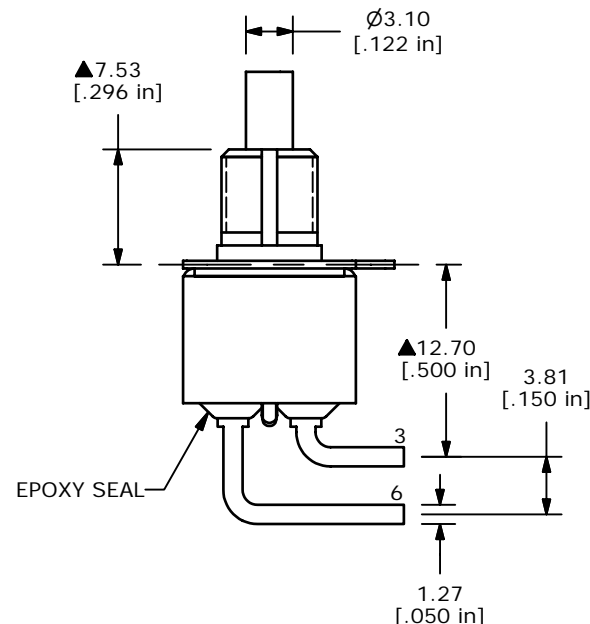
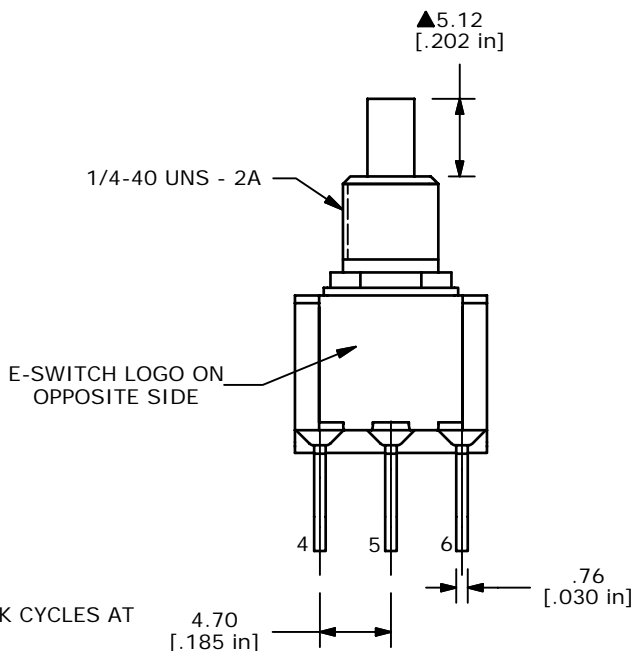

B	16429	REVISED AND REDRAWN	9/12/06	BO
A	13977	RELEASED FOR PRODUCTION	5/21/04	AR
REV	PCR NO	DESCRIPTION	DATE	BY

THE INFORMATION CONTAINED IN THIS DOCUMENT IS PROPRIETARY TO E-SWITCH AND IS NOT TO BE COPIED OR TRANSFERRED

E-SWITCH®				
TITLE 700DP7B10M6QE				
SCALE	DATE	DR	DWG	REV
2:1	5/21/2004	AR	T721004	B