

RECOMMENDED P.C.B. LAYOUT

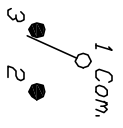
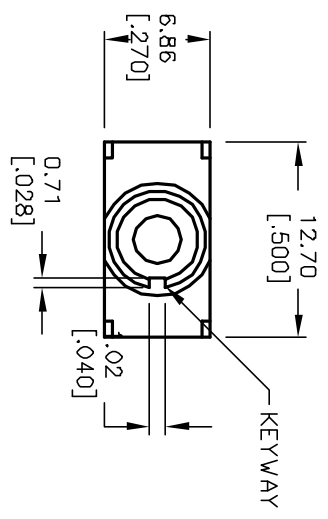

CIRCUIT: SPDT

SWITCH FUNCTION	
DN	<DN>
1-3	1-2

< > = MOMENTARY

NOTES:

1. ALL DIMENSIONS IN MM [INCH]
2. GENERAL TOLERANCE: X.X=±0.4  
X.XX=±0.25
3. TERM. NOS. FOR REF. ONLY
4. RATING: 1A @120VAC or 28VDC
5. FIXED TERM. & MOVING CONTACT:  
Copper Alloy w/Silver plate
6. CONTACT RESISTANCE: 10mILLI-ohms initial  
@2-4VDC
7. ELECTRICAL LIFE: 50,000 make-and-break  
cycles at full load.
8. INSULATION RESISTANCE: 1,000M ohm min.
9. DIELECTRIC STRENGTH: 1000V RMS @sea level
10. OPERATING TEMP.: -30°C to 85°C

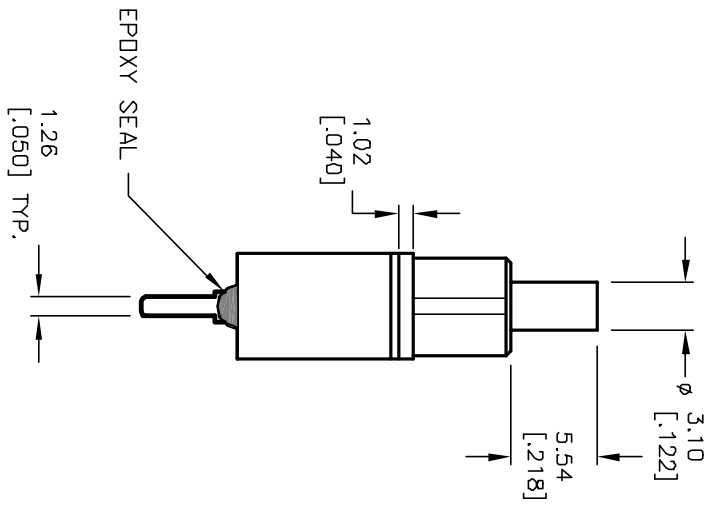
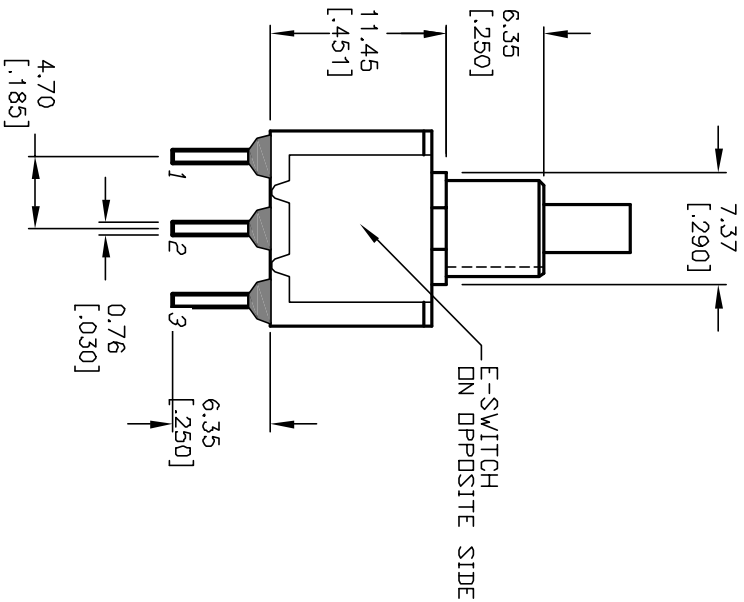

REV.	ECN No.	REVISION AND REDRAWN	DATE	CHKD
B		7/9/02	CJB	
DESCRIPTION				
THE INFORMATION CONTAINED IN THIS DOCUMENT IS PROPRIETARY TO E-SWITCH AND IS NOT TO BE COPIED OR TRANSFERRED				

TITLE	SCALE	DATE	DR	DWG	REV
700 SP-7 B20 M2 Q E	2:1	7/9/02	--	T711012	B

**E-SWITCH®**