

ITEM	QTY.	PART NO.	PART DESCRIPTION
1	1	F040006	D16 EE R11
2	1	F051202	50-012-02 (RED lens)

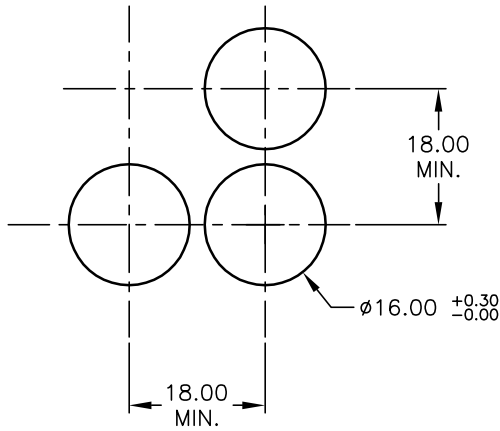

RECOMMENDED PANEL MOUNTING

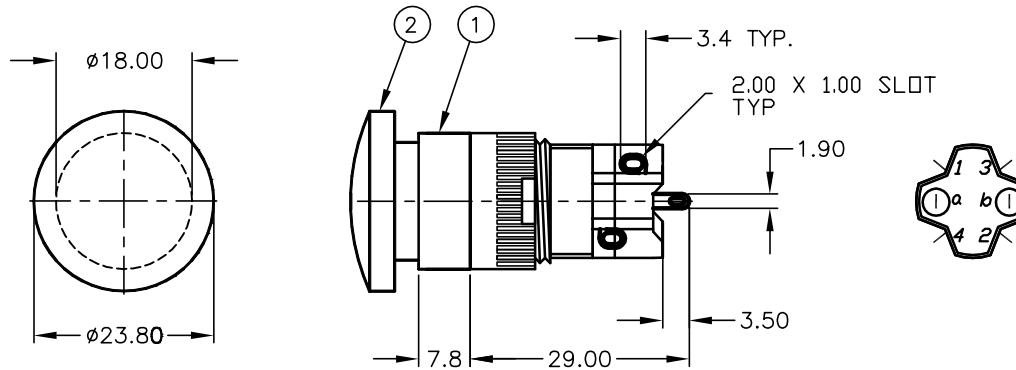

1 0 0 2
 3 0 0 4
 a-(L)-b (+)

SPST
 CONTACT CONFIGURATION

NOTES:

1. ALL DIMENSIONS IN MM
2. GENERAL TOLERANCE: X.X=±0.4
 X.XX=±0.25
3. RATINGS: 8A@125V or 5A@250V
4. CONTACTS: Copper Alloy w/Silver Plate.
5. TRAVEL: 3mm

E-SWITCH®

A	13426	RELEASED FOR PRODUCTION	9/4/03	AR
REV.	ECN No.	DESCRIPTION	DATE	CHKD

TITLE					D16EER10RED				
SCALE	DATE	DR	DWG	REV	SCALE	DATE	DR	DWG	REV
1:1	9/4/03	MM	XF0339P	A					

THE INFORMATION CONTAINED IN THIS DOCUMENT IS PROPRIETARY TO E-SWITCH AND IS NOT TO BE COPIED OR TRANSFERRED