

ITEM	QTY	PART NUMBER	DESCRIPTION
1	1	F040006	D16EER11
2	1	F050115	ROUND FLAT RED

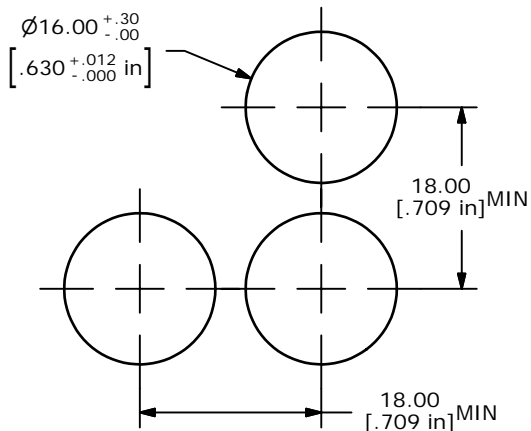

PANEL MOUNTING.

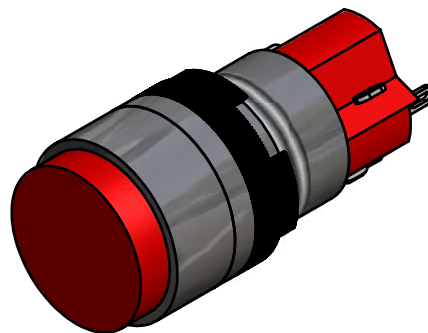

ISOMETRIC

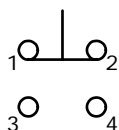

SPDT
CONTACT CONFIGURATION

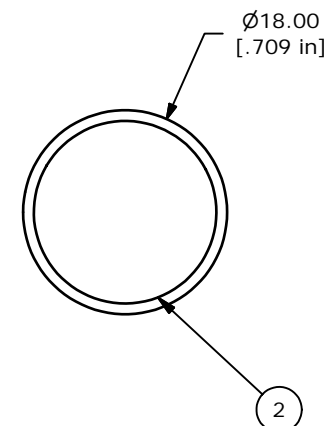
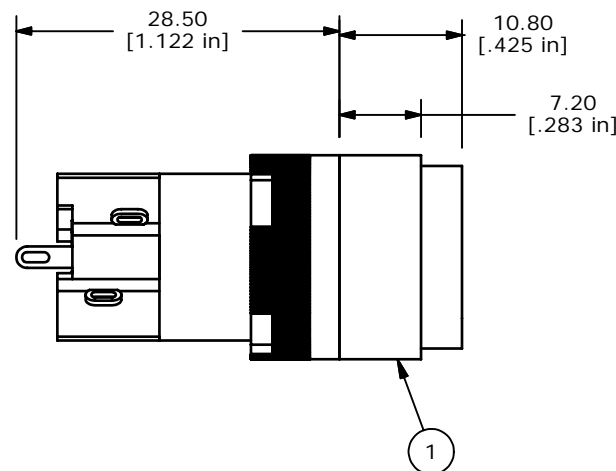
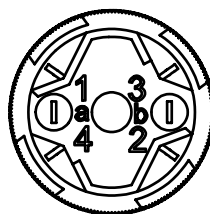

NOTE:

1. ALL DIMENSIONS IN MM [INCH]
2. GENERAL TOLERANCE: X.X=±0.4
X.XX=±0.25
3. TERMINAL NUMBERS FOR REF ONLY
4. MECHANICAL LIFE: 2,000,000 OPERATIONS
5. INSULATION RESISTANCE: 1,000 MEGA-OHM MIN.
6. OPERATING TEMP.: -25°C to 70°C
- ▲ 7. LAMP VOLTAGE: NO LAMP
8. CONTACT RATING: 5A @ 250 VAC
6A @ 240 VAC
9. ▲ DENOTES CRITICAL PARAMETER.

E-SWITCH®

A	15353	RELEASED FOR PRODUCTION	10/3/05	PH
REV	PCR NO	DESCRIPTION	DATE	BY

TITLE D16EER110RED				
SCALE	DATE	DR	DWG	REV
2:1	10/3/2005	PH	XF0647P	A

THE INFORMATION CONTAINED IN THIS DOCUMENT IS PROPRIETARY TO E-SWITCH AND IS NOT TO BE COPIED OR TRANSFERRED