

Parts List			
ITEM	QTY	PART NUMBER	DESCRIPTION
1	1	F060603	LASEEV12
2	1	F051702	25MM RING FOR LA SERIES
3	1	F060205	25MM WHITE LENS
4	1	F050405	28V AC/DC INCANDESCENT

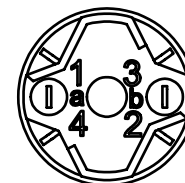
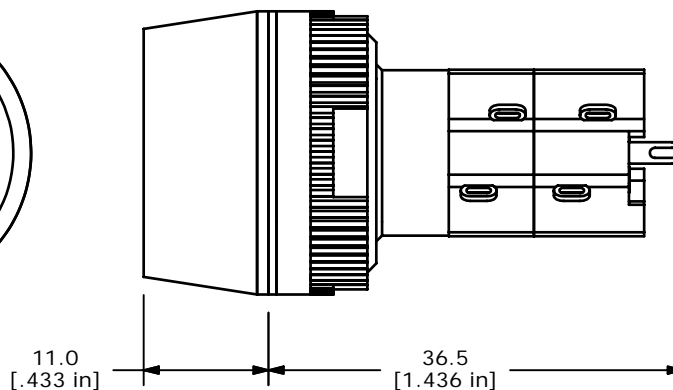
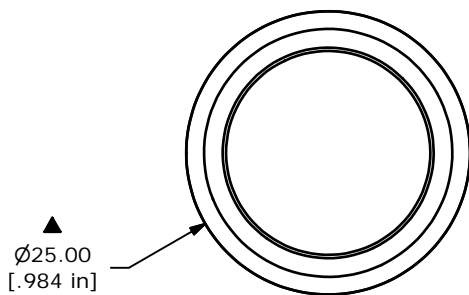
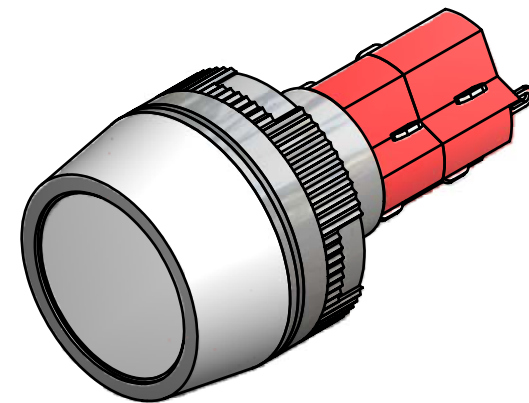

- NOTE:
1. ALL DIMENSIONS IN MM [INCH]
 2. GENERAL TOLERANCE: X.X=±0.4
X.XX=±0.25
 3. TERMINAL NUMBERS FOR REF ONLY
 4. RATING: 5A @ 250 VAC
6A @ 24 VDC
 5. ELECTRIC LIFE: 50,000 MAKE-AND-BREAK CYCLES AT FULL LOAD.
 6. INSULATION RESISTANCE: 1,000 MEGA-OHM MIN.
 7. OPERATING TEMP.: -20°C to 55°C
 - ▲ 8. LAMP VOLTAGE: 28V AC/DC 40mA
 9. ▲ DENOTES CRITICAL PARAMETER.
 10. 2002/05/EC (ROHS) COMPLIANT.

E-SWITCH®

A	16539	RELEASED FOR PRODUCTION	10/18/2006	TN
REV	PCR NO	DESCRIPTION	DATE	BY

TITLE LASEEV12CWHT				
SCALE	DATE	DR	DWG	REV
1.5:1	10/18/2006	TN	XF0692P	A

THE INFORMATION CONTAINED IN THIS DOCUMENT IS PROPRIETARY TO E-SWITCH AND IS NOT TO BE COPIED OR TRANSFERRED