

THIS DRAWING IS UNPUBLISHED. RELEASED FOR PUBLICATION
 © COPYRIGHT BY TYCO ELECTRONICS CORPORATION. ALL RIGHTS RESERVED.

LOC		DIST		REVISIONS			
AD	00	P	LTR	DESCRIPTION	DATE	DWN	APVD
		A		ECO-06-000221	04JAN06	MZ	MZ

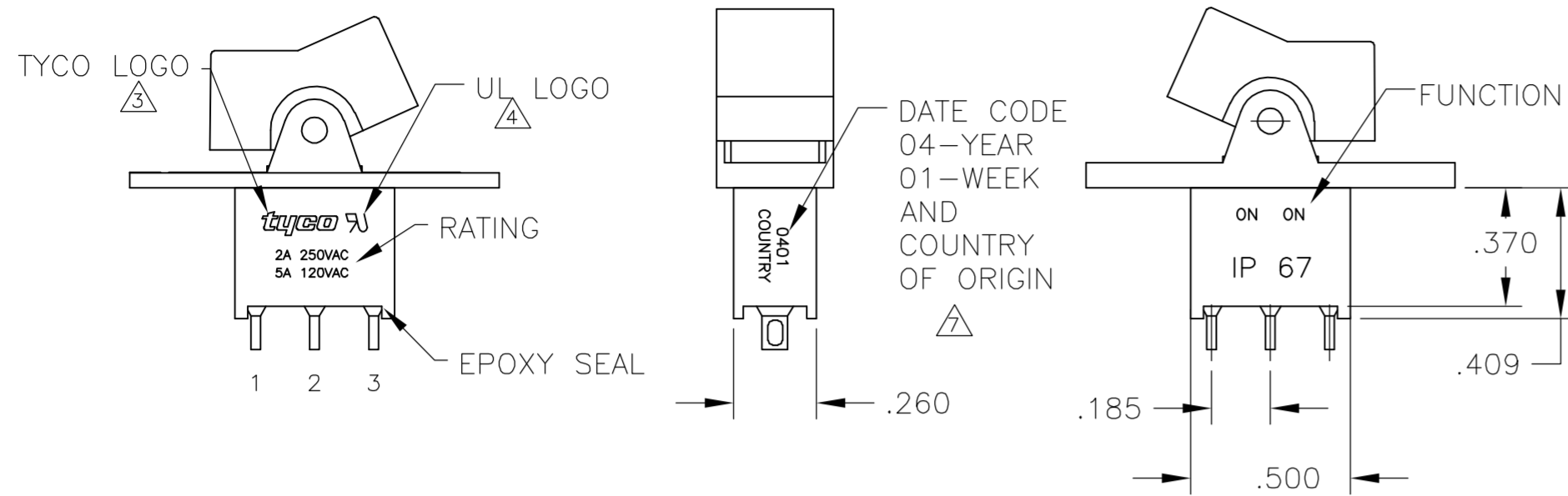

1. ALL MATERIALS AND FINISHES SHALL COMPLY WITH EU DIRECTIVE 2002/95/EC OF 27JAN2003 (ROHS).
 2. G CONTACT OPTION CAN BE USED FOR SIGNAL OR POWER LEVEL SWITCHING. IF SWITCH IS USED AT LEVELS EXCEEDING .4VA @ 20V AC/DC, SWITCH IS RENDERED FOR POWER SWITCHING ONLY DUE TO ARC REMOVAL OF GOLD PLATING. RATING STAMPED ON THE SWITCH IS 2A 250VAC, 5A 120VAC.
- △3 TYCO LOGO.
 - △4 UL RECOGNITION LOGO, G & Q CONTACT MATERIALS
 - 5. SWITCHES MEET REQUIREMENTS OF IP67
 - △6 PANEL MOUNT ACTUATOR PIVOT SUPPLIED WITH C, W, W4, Z & Z3 TERMINATIONS. PC MOUNT ACTUATOR PIVOT SUPPLIED WITH A, AV2, V3 & V4 TERMINATIONS
 - △7 DATE CODE AND COUNTRY OF ORIGIN MAY APPEAR ON EITHER SIDE OF SWITCH.

FUNCTION CHART

FUNCTION	TYCO	TYCO	TYCO
	1 2 3	1 2 3	1 2 3
01	ON	NONE	ON
03	ON	OFF	ON
05	(ON)	OFF	(ON)
07	ON	OFF	(ON)
08	ON	NONE	(ON)
TERMINALS CONNECTED	2-3	---	1-2

NONE: NO MECHANICAL POSITION
 OFF: MECHANICAL POSITION WITH NO ELECTRICAL CONNECTION
 (ON): MOMENTARY ACTION

SPECIFICATIONS

RATING, B CONTACTS	.4VA MAX @20V MAX. AC OR DC
RATING, G CONTACTS--SEE NOTE 2	.4VA MAX @20V MAX. AC OR DC OR
	5A @120 VAC OR 28 VDC (RESISTIVE)
RATING, Q CONTACTS	2A @250 VAC (RESISTIVE)
	5A @120 VAC OR 28 VDC (RESISTIVE)
ELECTRICAL LIFE	30,000 CYCLES AT RATED LOAD
CONTACT RESISTANCE	10 MILLIOHMS MAX INITIAL @ 2-4VDC, 100MA
INSULATION RESISTANCE	1,000 MEGOHMS MIN
DIELECTRIC WITHSTANDING VOLTAGE	1,000 V RMS AT SEA LEVEL
OPERATING TEMPRATURE	-30C TO 85C

Part Number Sequence

Model	Function	Toggle	Terminal	Contact	Actuator color	RoHS
AE1						04
	01	J1	A	B	0 BLACK (STD)	
	03	J50	AV2	G	1 BROWN	
	05	J2	C	Q	2 RED	
	07	J60	V3		3 ORANGE	
	08		V4		4 YELLOW	
			W		5 GREEN	
			W4		6 BLUE	
			Z		8 GRAY	
			Z3		9 WHITE	

THIS DRAWING IS A CONTROLLED DOCUMENT.

DWN	M.BINNER	06JAN05	Tyco Electronics Corporation Harrisburg, Pa 17105-3608
CHK	M.ZITTO	06JAN05	
APVD	M.ZITTO	06JAN05	
PRODUCT SPEC			
DIMENSIONS: INCHES TOLERANCES UNLESS OTHERWISE SPECIFIED: 0 PLC ± - 1 PLC ± - 2 PLC ± - 3 PLC ± .010 4 PLC ± - ANGLES ± 4° MATERIAL - FINISH -			NAME GEMINI AE SERIES ROCKER SWITCH DOUBLE POLE
MATERIAL - FINISH - WEIGHT - CUSTOMER DRAWING			SIZE A2 CAGE CODE 00779 DRAWING NO C=1571988 RESTRICTED TO - SCALE 2:1 SHEET 1 of 5 REV A

1571988

THIS DRAWING IS UNPUBLISHED. RELEASED FOR PUBLICATION
 © COPYRIGHT BY TYCO ELECTRONICS CORPORATION. ALL RIGHTS RESERVED.

LOC	DIST	REVISIONS			
P	LTR	DESCRIPTION	DATE	DWN	APVD
AD	00	SEE SHEET 1	-	-	-

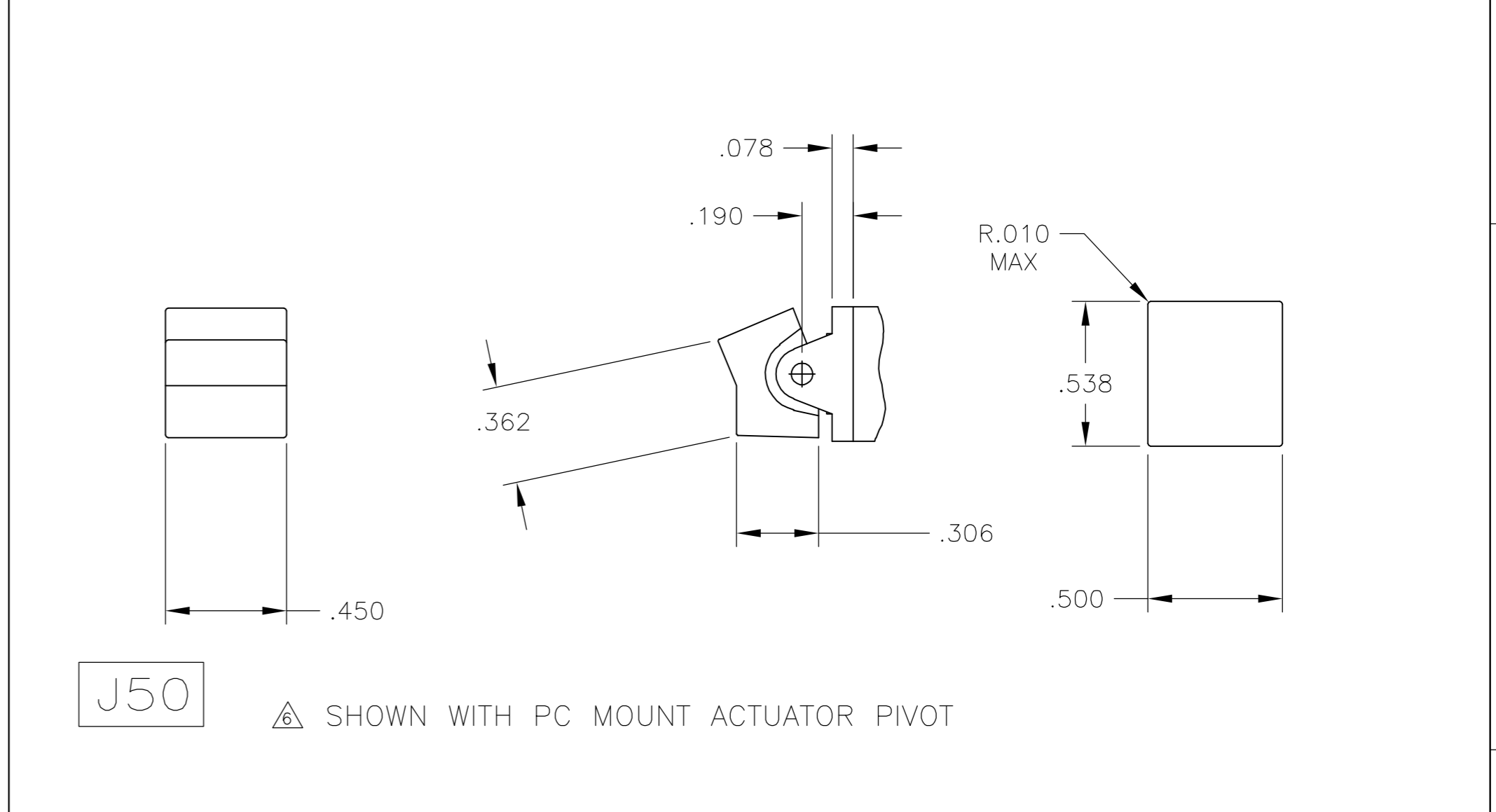
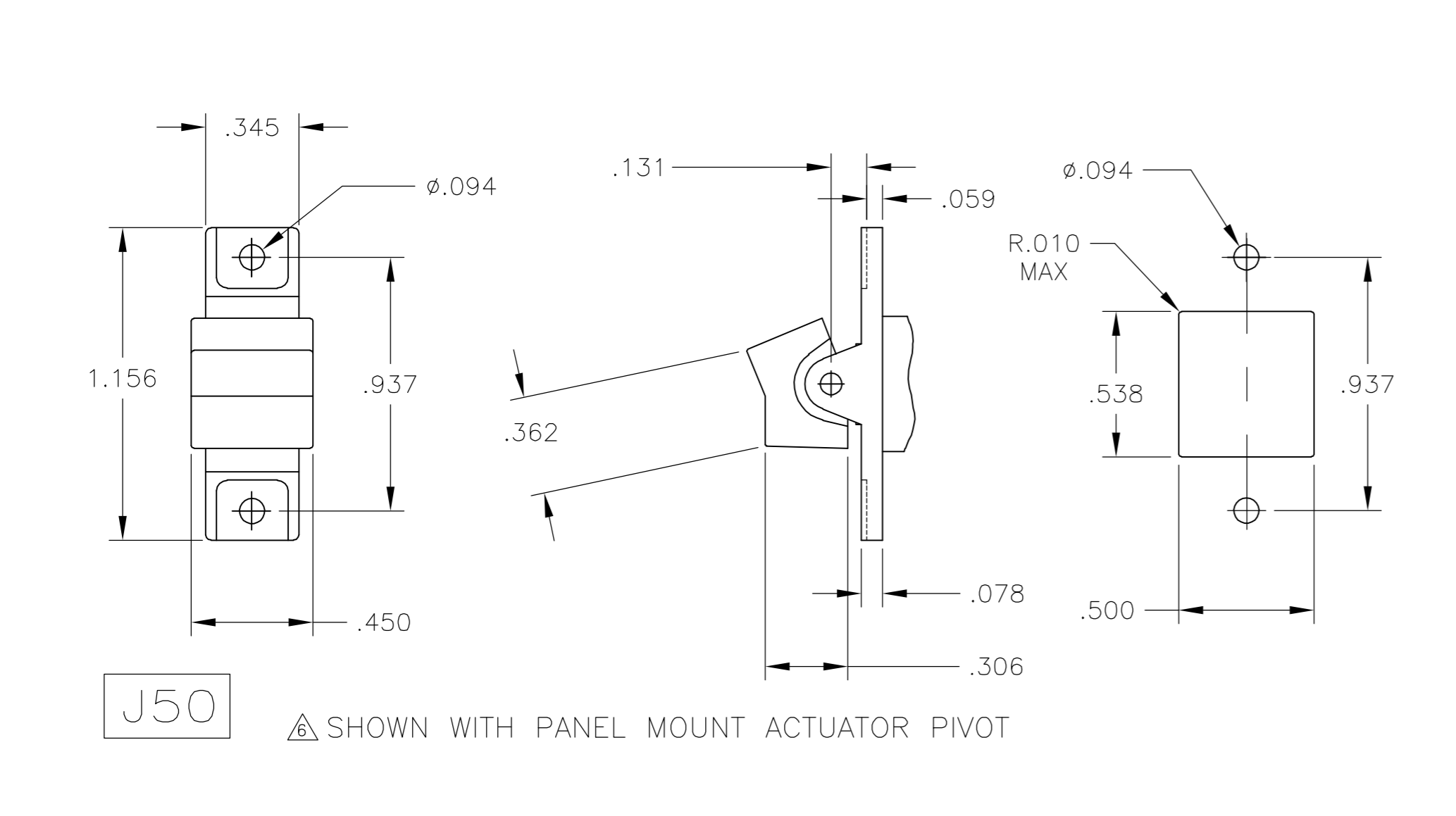
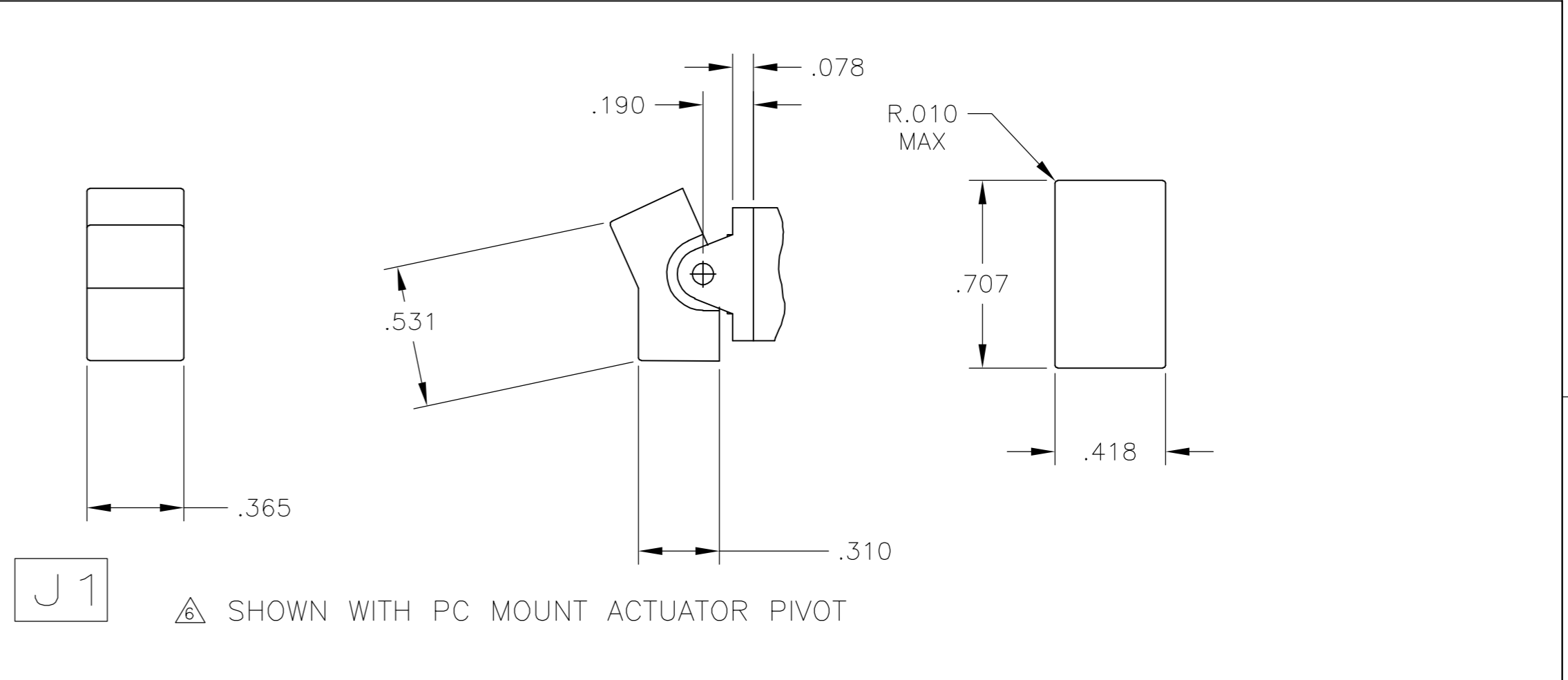
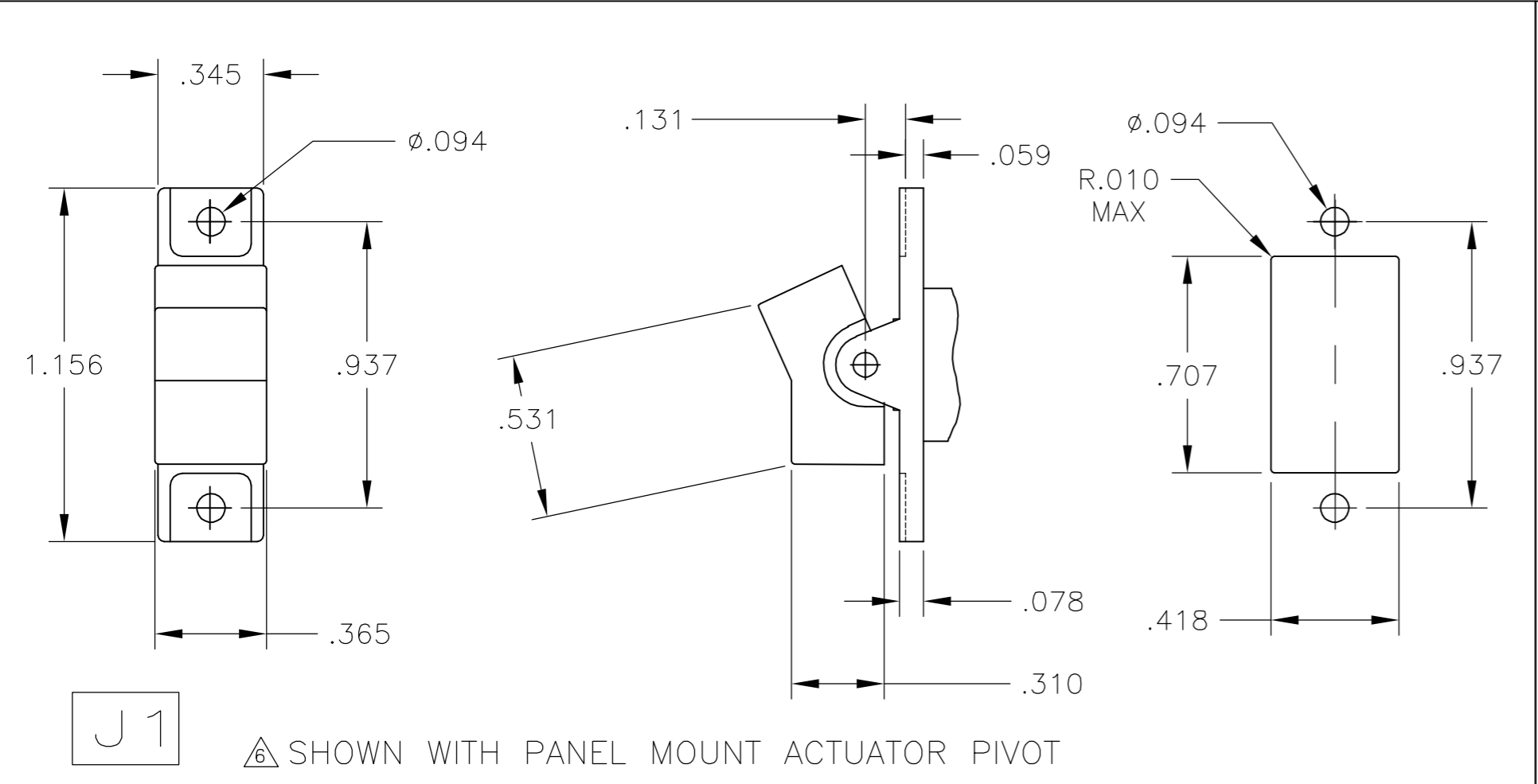

PANEL THICKNESS	DIM "A"
.047-.059	.619
.060-.125	.620-.625

THIS DRAWING IS A CONTROLLED DOCUMENT.		DWN	M.BINNER	07DEC04	Tyco Electronics Corporation Harrisburg, Pa 17105-3608
DIMENSIONS: INCHES		CHK	M.ZITTO	06JAN05	
TOLERANCES UNLESS OTHERWISE SPECIFIED:		APVD	M.ZITTO	06JAN05	
0 PLC ± - 1 PLC ± - 2 PLC ± - 3 PLC ± .010 4 PLC ± - ANGLES ± 4° FINISH -		PRODUCT SPEC	NAME		
MATERIAL		APPLICATION SPEC		GEMINI AE SERIES ROCKER SWITCH DOUBLE POLE	
-		WEIGHT	-	SIZE	A2
-		CUSTOMER DRAWING		CAGE CODE	00779
-		SCALE		DRAWING NO	C=1571988
-		2:1		RESTRICTED TO	-
-		SHEET		REV	A
-		2 of 5			

THIS DRAWING IS UNPUBLISHED. RELEASED FOR PUBLICATION
 © COPYRIGHT BY TYCO ELECTRONICS CORPORATION. ALL RIGHTS RESERVED.

LOC	DIST	REVISIONS			
P	LTR	DESCRIPTION	DATE	DWN	APVD
AD	00	SEE SHEET 1	-	-	-

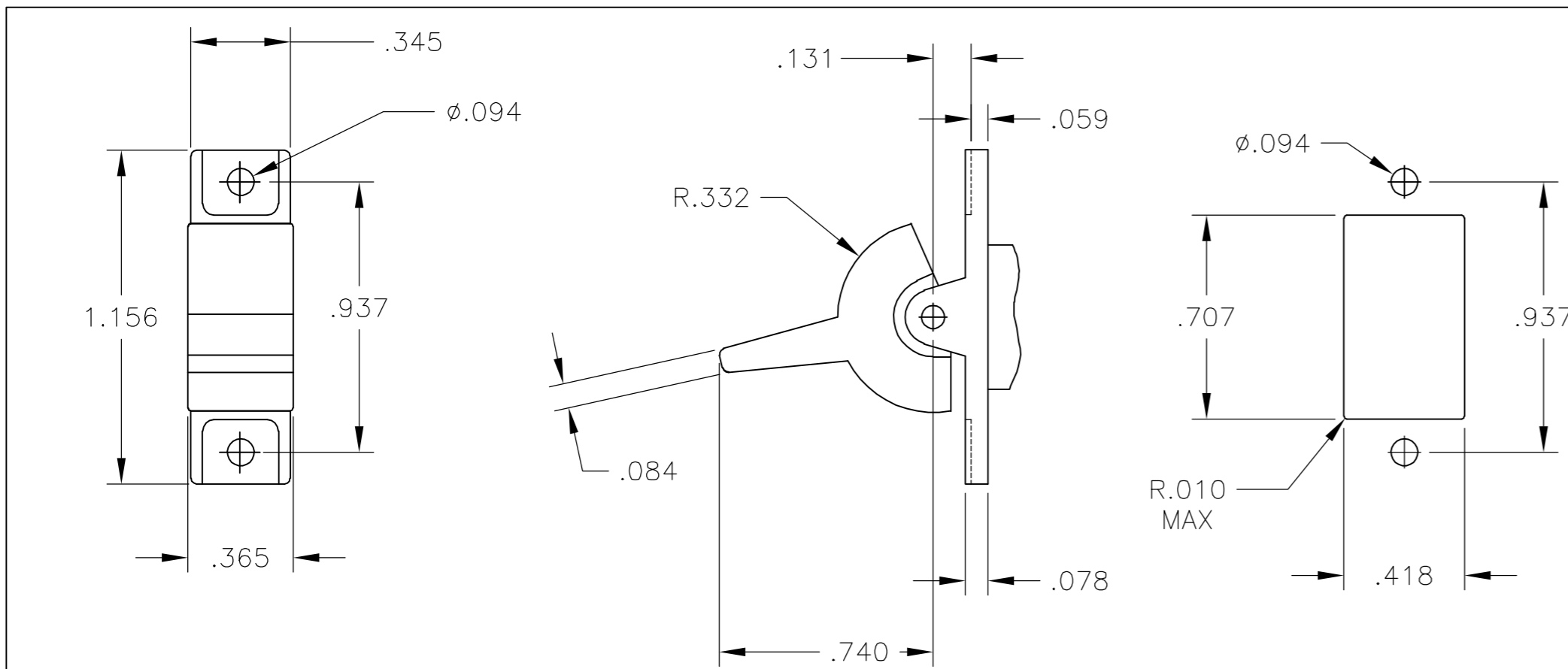

J2 SHOWN WITH PANEL MOUNT ACTUATOR PIVOT

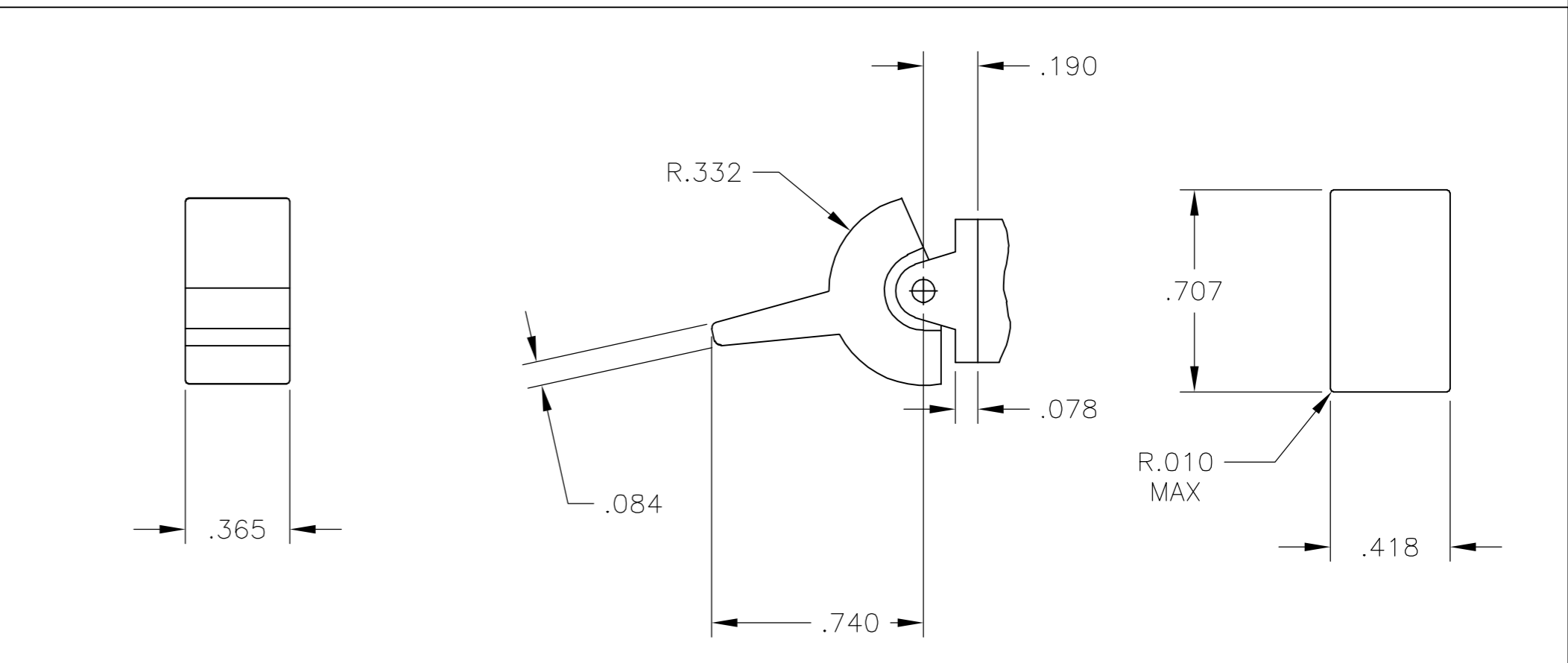

J2 SHOWN WITH PC MOUNT ACTUATOR PIVOT

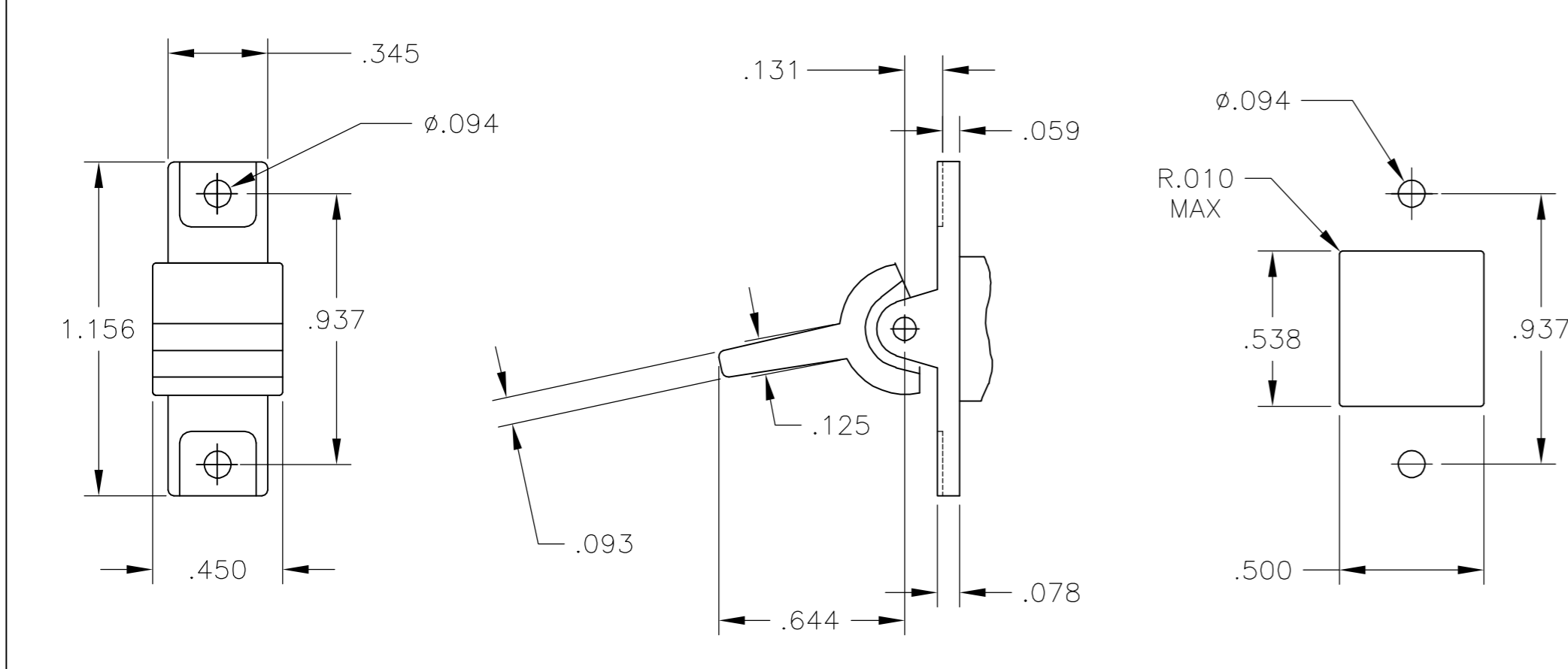

J60 SHOWN WITH PANEL MOUNT ACTUATOR PIVOT

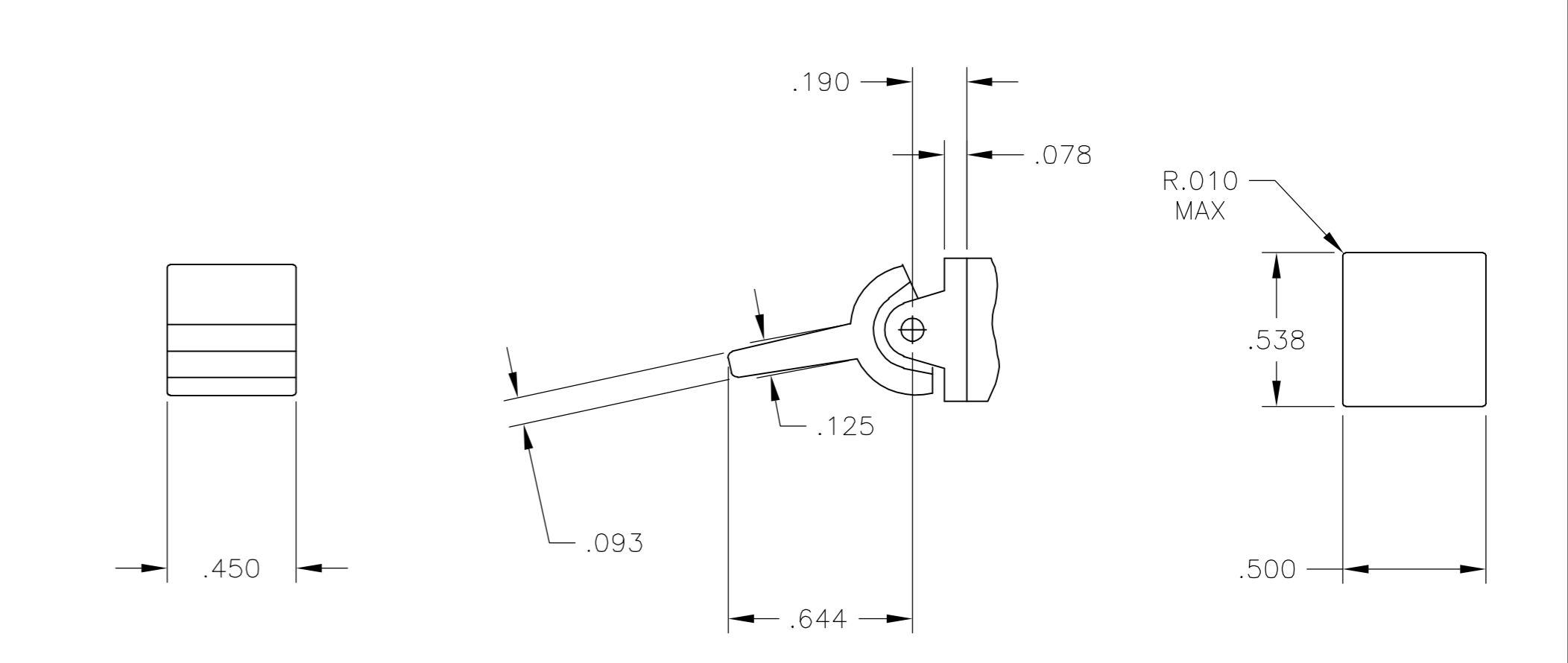

J60 SHOWN WITH PC MOUNT ACTUATOR PIVOT

PANEL THICKNESS	DIM "A"
.047-.059	.619
.060-.125	.620-.625

THIS DRAWING IS A CONTROLLED DOCUMENT.		DWN M.BINNER 07DEC04	Tyco Electronics Corporation Harrisburg, Pa 17105-3608	
DIMENSIONS: INCHES		CHK M.ZITTO 06JAN05		
TOLERANCES UNLESS OTHERWISE SPECIFIED:		APVD M.ZITTO 06JAN05	NAME GEMINI AE SERIES ROCKER SWITCH DOUBLE POLE	
0 PLC ± - 1 PLC ± - 2 PLC ± - 3 PLC ± .010 4 PLC ± - ANGLES ± 4°		PRODUCT SPEC	RESTRICTED TO	
MATERIAL		APPLICATION SPEC	SIZE A2	CAGE CODE 00779
FINISH		WEIGHT	DRAWING NO C=1571988	
		CUSTOMER DRAWING	SCALE 2:1	SHEET 3 of 5

1571988

THIS DRAWING IS UNPUBLISHED. RELEASED FOR PUBLICATION
 © COPYRIGHT BY TYCO ELECTRONICS CORPORATION. ALL RIGHTS RESERVED.

LOC		DIST		REVISIONS			
P	LTR	DESCRIPTION	DATE	DWN	APVD		
AD	00	SEE SHEET 1					

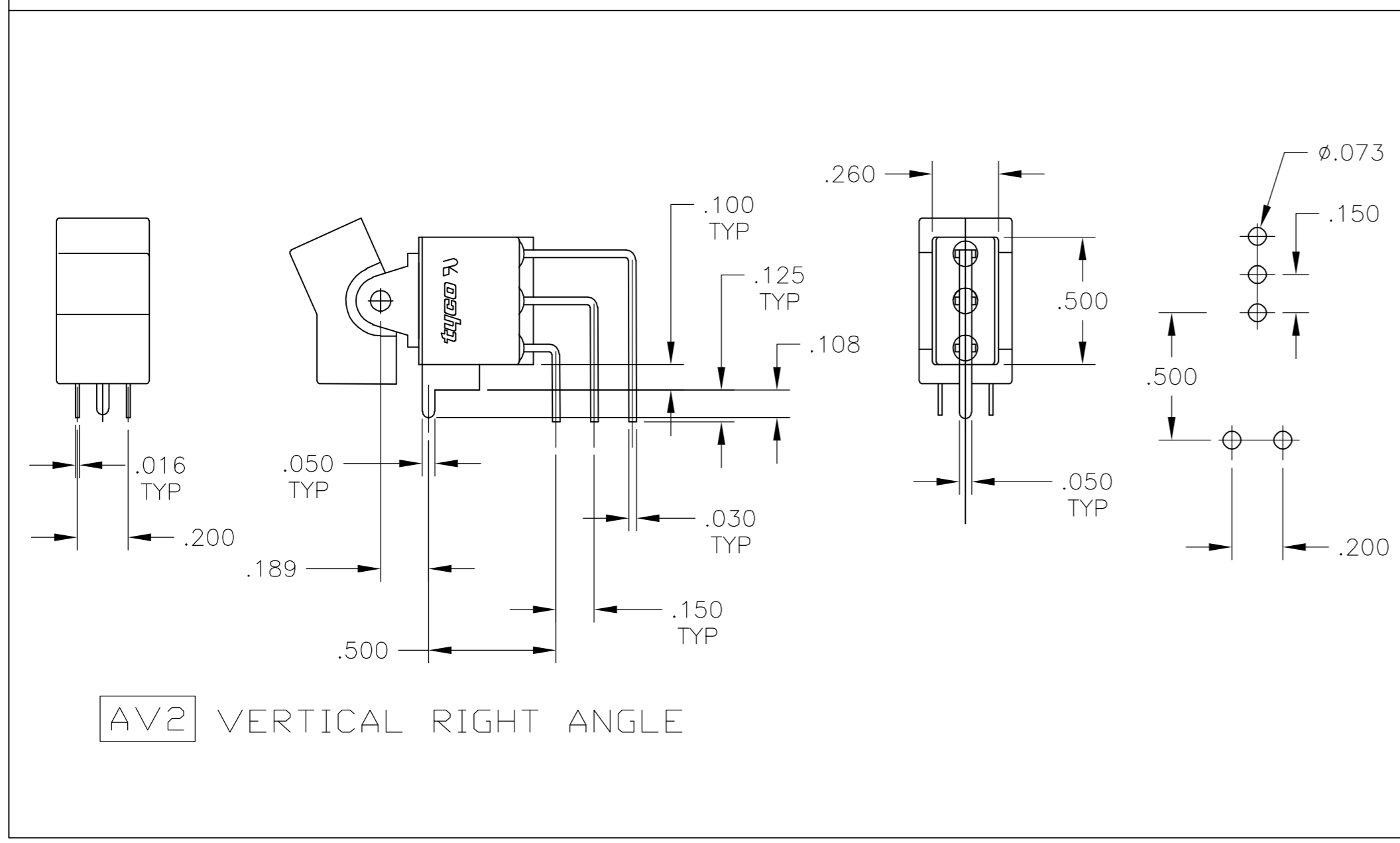
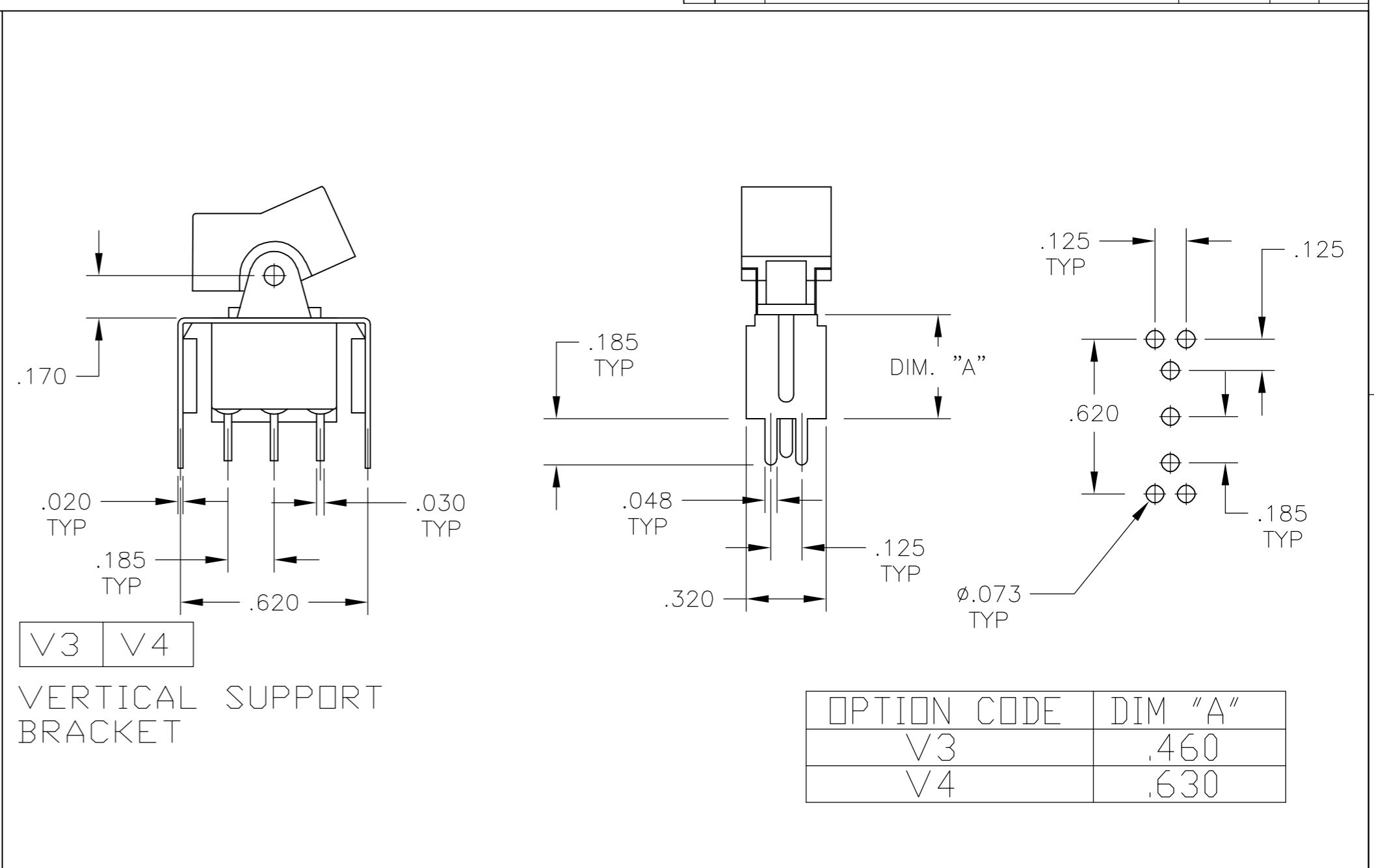
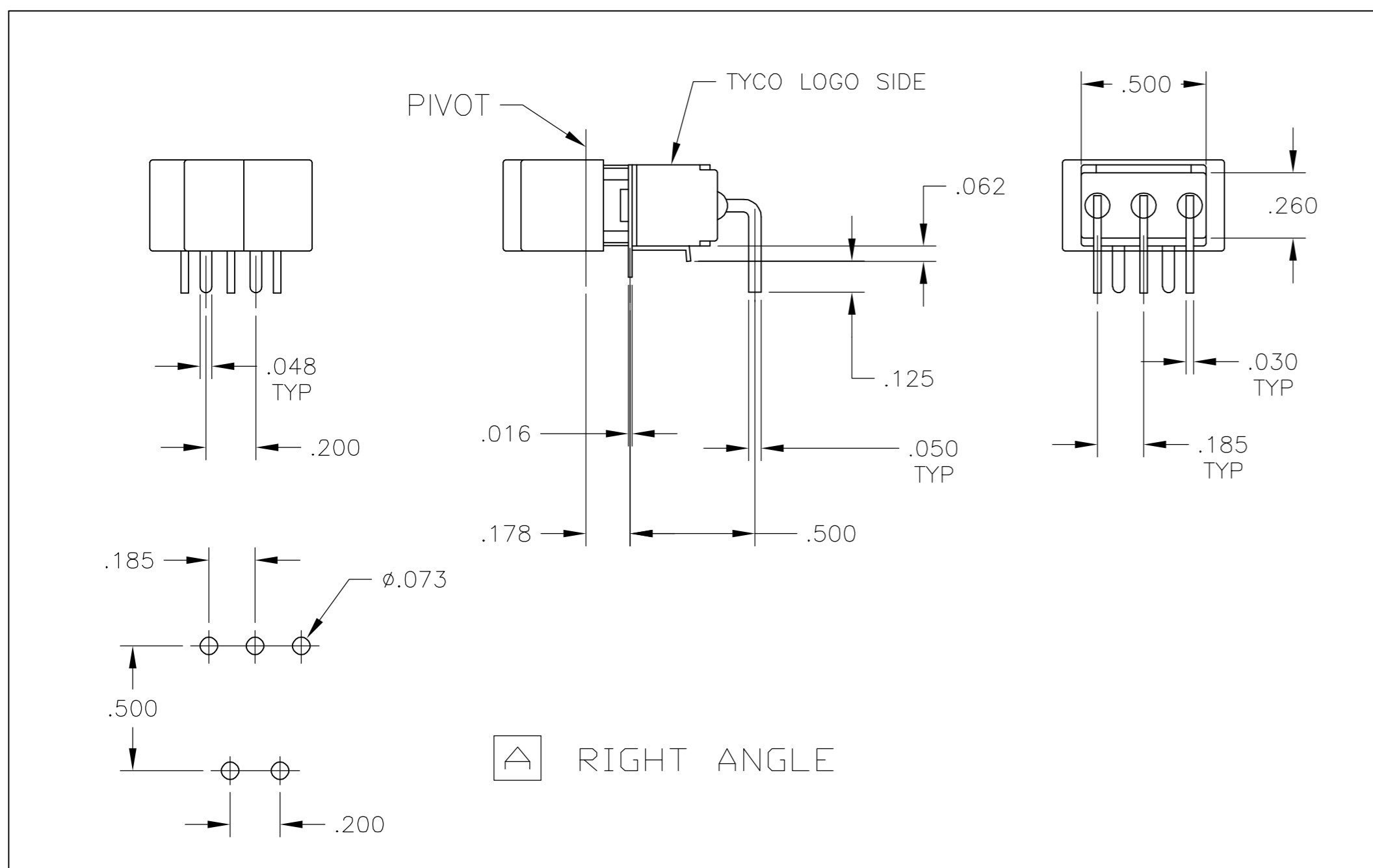

THIS DRAWING IS A CONTROLLED DOCUMENT.		DWN M.BINNER 07DEC04	tyco Tyco Electronics Corporation Harrisburg, Pa 17105-3608	
DIMENSIONS: INCHES		CHK M.ZITTO 06JAN05	NAME GEMINI AE SERIES ROCKER SWITCH DOUBLE POLE	
TOLERANCES UNLESS OTHERWISE SPECIFIED: 0 PLC ± - 1 PLC ± - 2 PLC ± - 3 PLC ± .010 4 PLC ± - ANGLES ± 4°		APVD M.ZITTO 06JAN05	PRODUCT SPEC APPLICATION SPEC	
MATERIAL		WEIGHT	SIZE A2	CAGE CODE 00779
FINISH		CUSTOMER DRAWING	DRAWING NO C=1571988	RESTRICTED TO
		SCALE 2:1	SHEET 4 of 5	REV A

THIS DRAWING IS UNPUBLISHED. RELEASED FOR PUBLICATION
 © COPYRIGHT BY TYCO ELECTRONICS CORPORATION. ALL RIGHTS RESERVED.

LOC	DIST	REVISIONS			
P	LTR	DESCRIPTION	DATE	DWN	APVD
AD	00	SEE SHEET 1	-	-	-

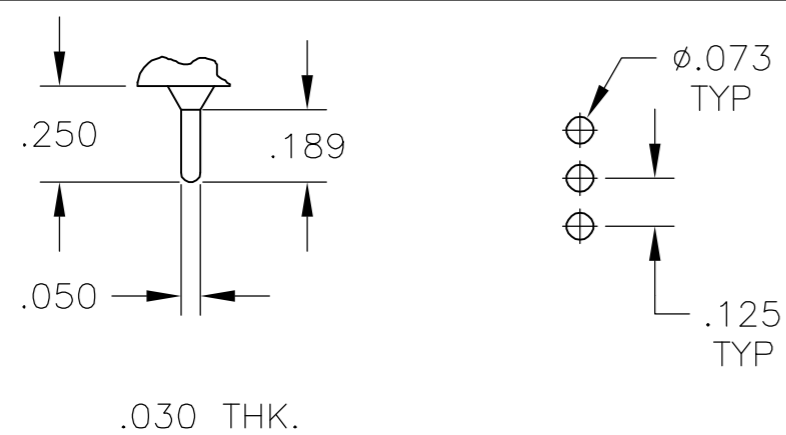

C PRINTED CIRCUIT

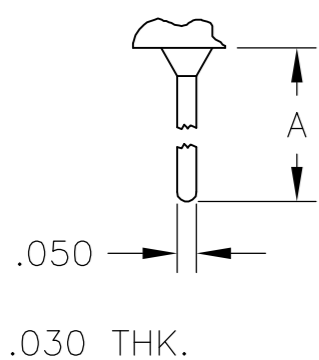

OPTION	DIM A
W	.736
W4	1.062

W **W4** WIRE WRAP

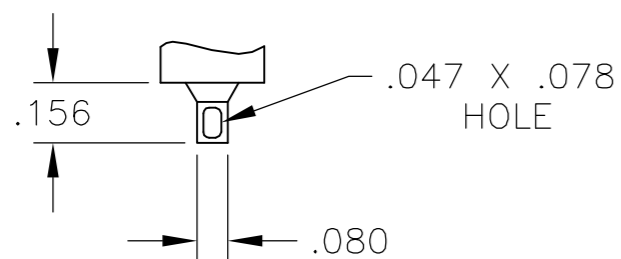

.030 THK.

Z WIRE LUG

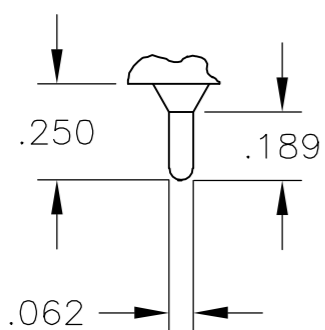

.030 THK.

Z3 QUICK CONNECT

MATERIALS CHART

COMPONENT NAME	BASE MATERIAL	FINISH
CASE & BUSHING	NYLON, RED, UL94 V-0	
O-RING	PVC, BLACK	
B TERMINALS & CONTACTS	COPPER	GOLD NICKEL
G TERMINALS & CONTACTS	COPPER	GOLD OVER SILVER
Q TERMINALS & CONTACTS	COPPER	SILVER
ACTUATOR	PHENOLIC, BLACK, UL94 V-1	
ACTUATOR LEVER	ZINC ALLOY	NICKEL
SPRING	MUSIC WIRE	
PIVOT PIN	STEEL	NICKEL
MOUNTING BRACKET	NYLON, UL94 V-1	
ROCKER CAP	NYLON, UL94 V-1	
TERMINAL SEAL	EPOXY, UL94V-0	
MARKING	INK, BLACK	
SUPPORT BRACKET	BRASS	TIN
RETAINER	STAINLESS STEEL	

PRELIMINARY	AE101J3V31Q004	1-1571988-7
	AE108J60V3B004	1-1571988-6
	AE108J1ZQ004	1-1571988-5
	AE107J1ZQ004	1-1571988-4
	AE107J1AQ004	1-1571988-3
	AE105J60V3B004	1-1571988-2
	AE105J1ZB004	1-1571988-1
	AE105J1V3B004	1-1571988-0
	AE105J1AQ004	1571988-9
	AE103J60V3Q204	1571988-8
	AE103J50V3B004	1571988-7
	AE101J1V3Q004	1571988-6
	AE101J1V3B004	1571988-5
	AE101J1AV2Q004	1571988-4
	AE101J1AQ404	1571988-3
	AE101J1AQ004	1571988-2
	AE101J1AB004	1571988-1
	Alco P/N	Tyco P/N

THIS DRAWING IS A CONTROLLED DOCUMENT.		DWN M.BINNER 07DEC04	Tyco Electronics Corporation Harrisburg, Pa 17105-3608	
DIMENSIONS: INCHES		CHK M.ZITTO 06JAN05		
TOLERANCES UNLESS OTHERWISE SPECIFIED:		APVD M.ZITTO 06JAN05	NAME GEMINI AE SERIES ROCKER SWITCH DOUBLE POLE	
0 PLC ± - 1 PLC ± - 2 PLC ± - 3 PLC ± .010 4 PLC ± - ANGLES ± 4°		PRODUCT SPEC	RESTRICTED TO	
MATERIAL		APPLICATION SPEC	SIZE A2	CAGE CODE 00779
FINISH		WEIGHT	DRAWING NO C=1571988	SCALE 2:1
		CUSTOMER DRAWING	SHEET 5 of 5	REV A