

RECOMMENDED P.C.B. LAYOUT

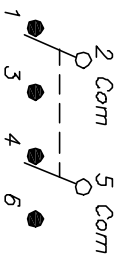

CIRCUIT: DPDT

NOTES:

1. ALL DIMENSIONS IN MM [INCH]
2. GENERAL TOLERANCE: X.X=±0.4
X.XX=±0.25
3. TERM. NOS. FOR REF. ONLY
4. RATING: 5A @120V AC or 28VDC;
2A @250V AC
5. FIXTED TERMINAL & MOVING CONTACT:
Copper Alloy w/ Silver plating
6. CONTACT RESISTANCE: 10mILLI Ohms max initial
@2-4VDC, 100mA for AG & AU
7. ELECTRICAL LIFE: 30,000 make-and-break
cycles at full load.
8. INSULATION RESISTANCE: 1,000M ohm min.
9. DIELECTRIC STRENGTH: 1000V RMS @sea level
10. OPERATING TEMP.: -30°C to 85°C
11. ROCKER: STD BLACK (UL94HB)

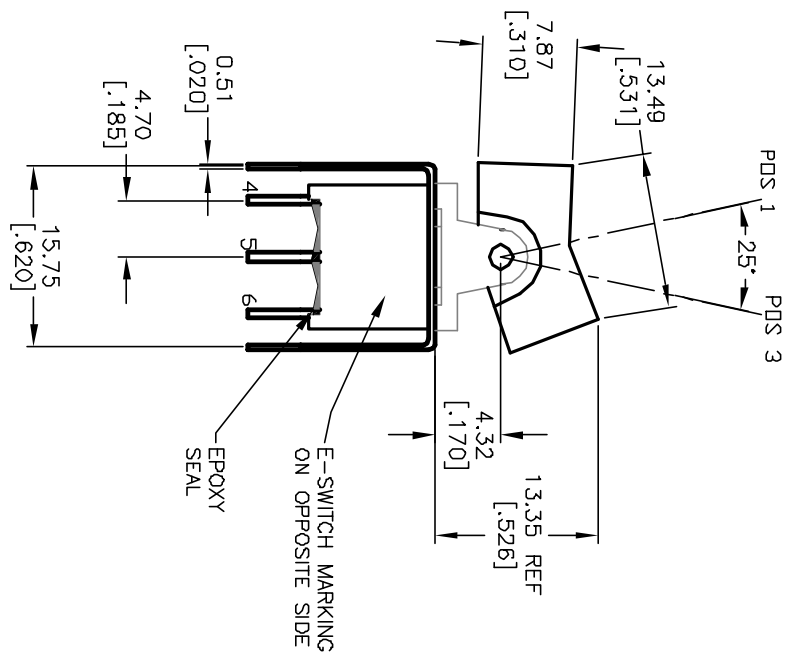

SWITCH FUNCTION		
	PDS. 1	PDS. 2
	DN	NDNE
	DN	DPEN
	2-3, 5-6	2-1, 5-4

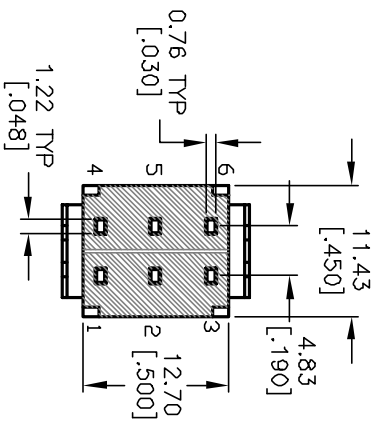
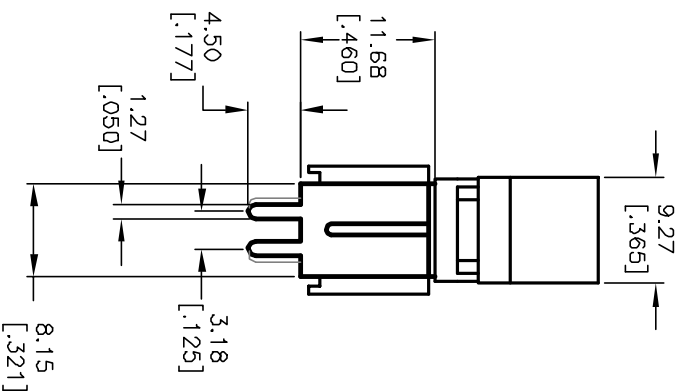

E-SWITCH®

REV.	ECN No.	DESCRIPTION	DATE	CHKD	SCALE	DATE	DR	DWG	REV
A	12569	RELEASED FOR PRODUCTION	11/18/02	CB	1.5:1	11/15/02	CJB	T301030	A
TITLE: 3004 WDP1 J1 VS2 Q E									
THE INFORMATION CONTAINED IN THIS DOCUMENT IS PROPRIETARY TO E-SWITCH AND IS NOT TO BE COPIED OR TRANSFERRED									