

ISOMETRIC

SWITCH FUNCTION		
POS. 1	POS. 2	POS. 3
ON	NONE	(ON)
2-3, 5-6	N/A	2-1, 5-4

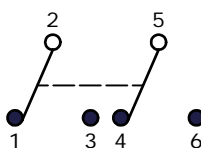

CIRCUIT: DPDT

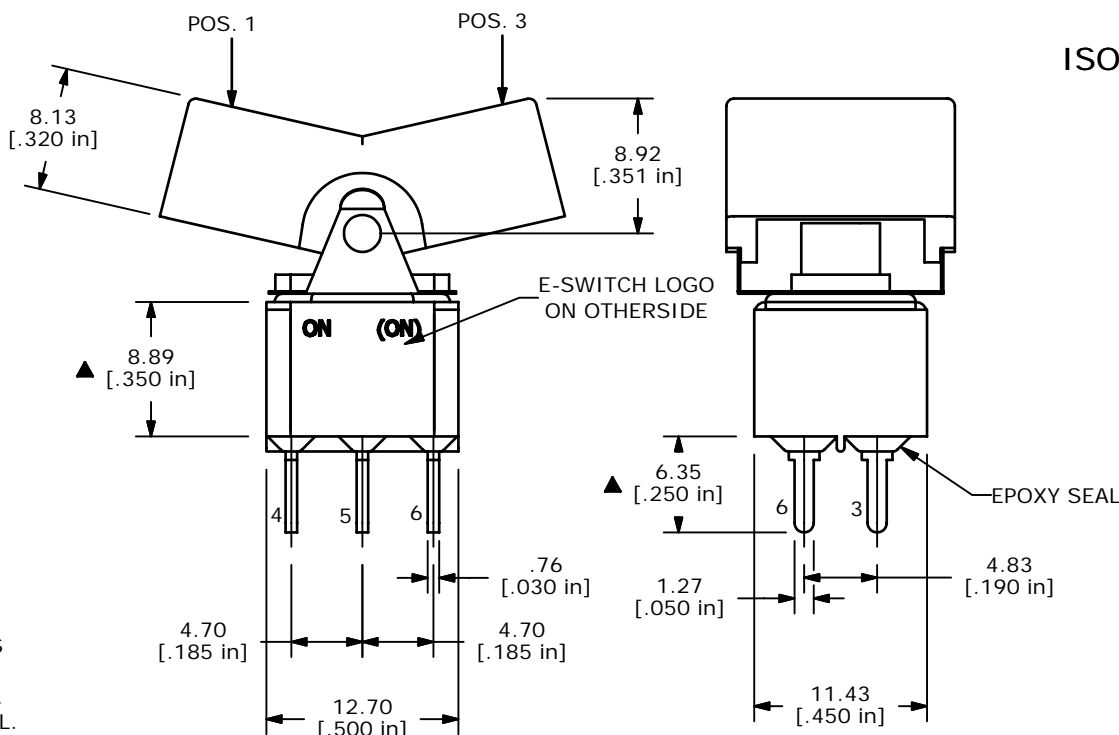

- NOTE:
1. ALL DIMENSIONS IN MM [INCH]
  2. GENERAL TOLERANCE: X.X=±0.4  
X.XX=±0.25
  3. TERMINAL NUMBERS FOR REF ONLY
  - ▲ 4. PLATING MATERIAL: SILVER
  5. RATING: 2 AMPS @250VAC  
5 AMPS @120VAC OR 28VDC
  6. ELECTRIC LIFE: 40,000 MAKE-AND-BREAK CYCLES AT FULL LOAD.
  7. INSULATION RESISTANCE: 1,000 MEGA-OHM MIN.
  8. DIELECTRIC STRENGTH: 1,000 V RMS @SEA LEVEL.
  9. OPERATING TEMP.: -30°C to 85°C
  10. ▲ DENOTES CRITICAL PARAMETER.
  11. 2002/95/EC (ROHS) COMPLIANT

**E-SWITCH®**

A	15782	RELEASED FOR PRODUCTION	2/16/06	PH
REV	PCR NO	DESCRIPTION	DATE	BY

TITLE 300DP2J3BLKM2QE

SCALE	DATE	DR	DWG	REV
2:1	2/16/2006	PH	T321021	A

THE INFORMATION CONTAINED IN THIS DOCUMENT IS PROPRIETARY TO E-SWITCH AND IS NOT TO BE COPIED OR TRANSFERRED