

BLACK BEZEL

RECOMMENDED PANEL MOUNTING

PANEL THICKNESS

1.52 TO 3.18

* DIMENSION IS 15.75/15.88 FOR PANEL THICKNESS BETWEEN 1.52mm TO 3.18mm

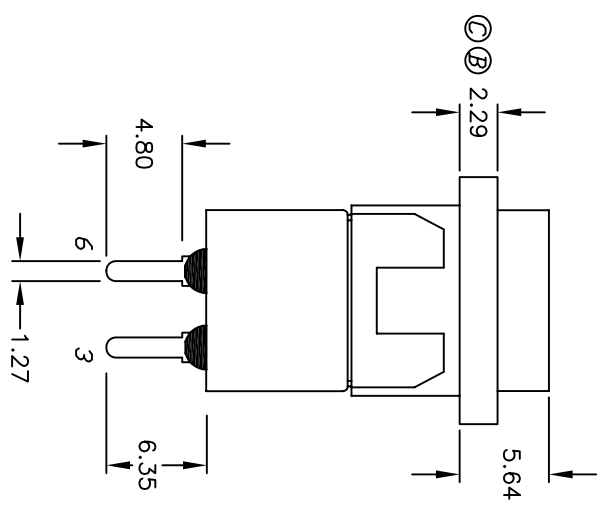
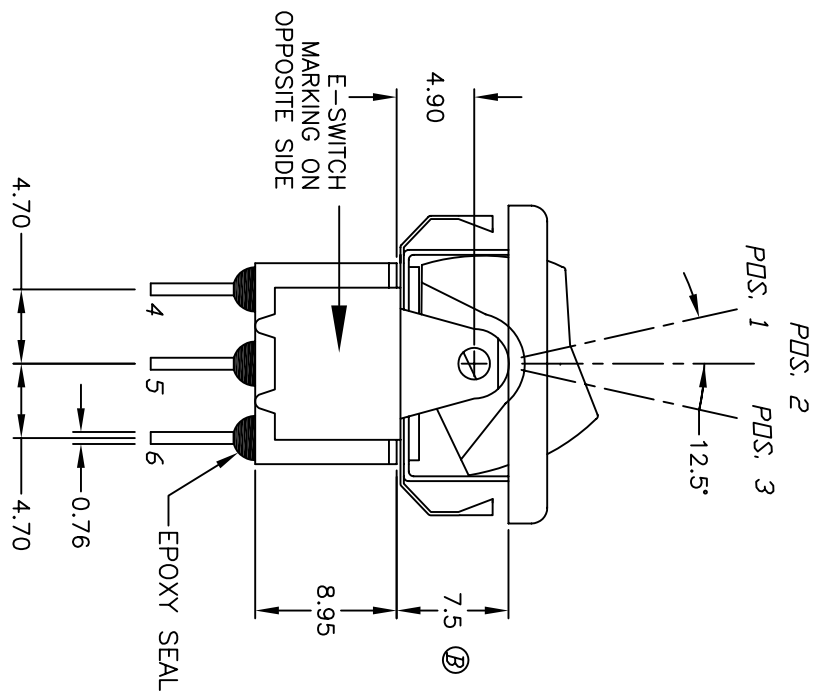

NOTES:

1. ALL DIMENSIONS IN MM [INCH]
2. GENERAL TOLERANCE: X.X=±0.4 X.XX=±0.25
3. TERM. NOS. FOR REF. ONLY
4. RATING: 5A @120VAC OR 28VDC 2A @250VAC
5. MATERIAL: FIXED TERMINAL & MOVING CONTACT Copper Alloy w/Silver Plate
6. CONTACT RESISTANCE: 10mILLI Ohms max initial @2-4VDC, 100mA for AG & AU
7. ELECTRICAL LIFE: 50,000 make-and-break cycles at full load.
8. INSULATION RESISTANCE: 1,000M ohm min.
9. DIELECTRIC STRENGTH: 1000V RMS @sea level
10. OPERATING TEMP.: -30°C to 85°C
11. 2002/95/EC (ROHS) COMPLIANT

SWITCH FUNCTION			
POS. 1	POS. 2	POS. 3	
DN	DN	DN	
2-3,5-6	2-3,5-4	2-1,5-4	

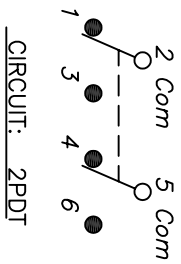

E-SWITCH®

REV.	ECN NO.	DESCRIPTION	DATE	CHKD
C	15547	DIM FROM 3.48 TO 2.29	11/18/05	PH
B	15452	DIMS FROM 7.11,2.40,19.43,15.24	10/25/05	PH
A	12728	RELEASED	1/16/03	CB

SCALE	DATE	DR	DWG	REV
2:1	1/14/03	CB	T326037	C

THE INFORMATION CONTAINED IN THIS DOCUMENT IS PROPRIETARY TO E-SWITCH AND IS NOT TO BE COPIED OR TRANSFERRED

300 DP-6 R6 BLK M2 Q E BLK